



Highway Department

Telephone: 701-298-2370

Fax: 701-298-2395

SMB-HWY@casscountynd.gov

MEMORANDUM

TO: Cass County Commission

FROM: Jason Benson, County Engineer

DATE: January 5, 2024

SUBJECT: Agenda Item for January 16th, 2024 Cass County Commission. Forest Mitigation Agreement

Forest Mitigation is part of a requirements set forth by USACE (United States Army Corps of Engineers) due to the impact from the Comprehensive project. The mitigation of this impact is meant to be done in accordance with the Section 404 Permit, the Forest Mitigation Plan, and the AMMP (Adaptive Management and Mitigation Plan). Some of the properties that have been identified for Forest Mitigation are Cass County Flood Buyout Properties. The purpose of the Forest Mitigation Agreement is to identify the selected properties, usage, and requirements as well as leasing documents for those lands. **Additions have been made to the list of the properties considered for use in the Forest Mitigations projects as in the number of those properties has increased. This change impacts the previously approved Forest Mitigation Agreement.**

SUGGESTED MOTION:

Move to approve the updated Cass County and Metro Flood Diversion Authority Forest Mitigation Agreement.

FOREST MITIGATION AGREEMENT

BY AND BETWEEN
METRO FLOOD DIVERSION AUTHORITY
AND
CASS COUNTY, NORTH DAKOTA

Dated as of _____, 2023

Relating to:

A Forest Mitigation Agreement setting forth the roles and responsibilities of the Parties for forest compensatory mitigation related to the Fargo-Moorhead Metropolitan Area Flood Risk Management Project.

This instrument was drafted by:
Ohnstad Twichell, P.C.
P.O. Box 458
West Fargo, North Dakota 58078

TABLE OF CONTENTS

ARTICLE I. DEFINITIONS AND INTERPRETATION	2
SECTION 1.01 DEFINITIONS	2
SECTION 1.02 INTERPRETATION	4
ARTICLE II. INTENT	4
SECTION 2.01 FOREST MITIGATION REQUIREMENTS	4
SECTION 2.02 SUBJECT TO CHANGE	4
ARTICLE III. DESIGN AND PLANTING	5
SECTION 3.01 DESIGN AND DESIGN STRATEGIES	5
SECTION 3.02 SITE PREPARATION	5
SECTION 3.03 MONITORING	5
ARTICLE IV. MONITORING AND MANAGEMENT	5
SECTION 4.01 POST-PLANTING MONITORING	5
SECTION 4.02 PERFORMANCE STANDARDS	5
SECTION 4.03 COUNTY RESTRICTIONS	6
ARTICLE V. INDEMNIFICATION	6
SECTION 5.01 INDEMNIFICATION.....	6
ARTICLE VI. TERM AND TERMINATION	6
SECTION 6.01 TERM.....	6
SECTION 6.02 TERMINATION	6
ARTICLE VII. DISPUTE RESOLUTION	6
SECTION 7.01 INTENT AND PROCEDURE	7
SECTION 7.02 MEDIATION.....	7
SECTION 7.03 LITIGATION.....	7
SECTION 7.04 VENUE.....	7
SECTION 7.05 WAIVER OF JURY TRIAL	7
ARTICLE VIII. MISCELLANEOUS.....	7
SECTION 8.01 COMPLETE AGREEMENT.....	7
SECTION 8.02 COUNTERPARTS.....	7
SECTION 8.03 AMENDMENTS	7
SECTION 8.04 SEVERABILITY AND SAVINGS CLAUSE.....	8
SECTION 8.05 FORCE MAJEURE	8
SECTION 8.06 AUTHORIZED REPRESENTATIVES.....	8
SECTION 8.07 NOTICE.....	8
SECTION 8.08 GOVERNING LAW	9
SECTION 8.09 CONFLICT WITH OTHER MOU	9
SECTION 8.10 CONFLICT WITH JOINT POWERS AGREEMENT.....	9
SECTION 8.11 ELECTRONIC SIGNATURES.....	9
Signature Pages	S-1 through S-2

- EXHIBIT A – County Parcel List and Map**
- EXHIBIT B – Current Version of the AMMP**
- EXHIBIT C – Current Version of the Forest Mitigation Plan**
- EXHIBIT D – Draft Conservation Easement**

FOREST MITIGATION AGREEMENT

THIS FOREST MITIGATION AGREEMENT (the “Agreement”) is made and entered into this ____ day of _____, 2023 (the “Effective Date”), by and between METRO FLOOD DIVERSION AUTHORITY, a political subdivision of the State of North Dakota, and CASS COUNTY, NORTH DAKOTA, a political subdivision and home rule county of the State of North Dakota.

WHEREAS, construction of the locally preferred plan for the Fargo-Moorhead Metropolitan Area Flood Risk Management Project (the “Comprehensive Project”) at the Fargo, North Dakota, and Moorhead, Minnesota, metropolitan area was authorized by Section 7002(2) of the Water Resources Reform and Development Act of 2014, Public Law 113-121; and

WHEREAS, the Authority, the City of Fargo, North Dakota, and the City of Moorhead, Minnesota, are the Non-Federal Sponsors of the Comprehensive Project and entered into a Project Partnership Agreement (the “PPA”) on July 11, 2016, with the United States Army Corps of Engineers (“USACE”) for the construction, operation, and maintenance of the Comprehensive Project; and

WHEREAS, the PPA sets forth a split delivery method for the Comprehensive Project establishing the respective responsibilities of both the Non-Federal Sponsors and USACE; and

WHEREAS, for the portion of the Comprehensive Project for which the Non-Federal Sponsors are responsible, USACE completed numerous environmental assessments and issued a permit in accordance with Section 404 of the Clean Water Act (the “Section 404 Permit”); and

WHEREAS, the Section 404 Permit requires the Non-Federal Sponsors to complete forest compensatory mitigation as a result of impacts, and the requirements for such forest compensatory mitigation are set forth in the Fargo-Moorhead Metropolitan Area Flood Risk Management Project, Forest Mitigation Plan (the “Forest Mitigation Plan”), created by USACE; and

WHEREAS, following the design and planting of the forest mitigation sites, the Non-Federal Sponsors are further required to provide on-going adaptive management and mitigation in accordance with the Fargo-Moorhead Metropolitan Area Flood Risk Management Project, Adaptive Management and Mitigation Plan (the “AMMP”), to monitor potential impacts over time; and

WHEREAS, the Non-Federal Sponsors assigned their responsibilities under the Section 404 Permit and for on-going adaptive management and mitigation to the Authority by entering into the Joint Powers Agreement; and

WHEREAS, certain parcels owned by the County were identified as locations in the Forest Mitigation Plan where forest mitigation could occur; and

WHEREAS, consequently, the Authority and the County now desire to enter into this Agreement to set forth their respective roles and responsibilities for current and on-going forest mitigation and monitoring.

NOW, THEREFORE, in consideration of the mutual covenants made herein and for other valuable consideration, the receipt of which is hereby acknowledged, the Authority and the County agree as follows:

**ARTICLE I.
DEFINITIONS AND INTERPRETATION**

Section 1.01 DEFINITIONS. All capitalized terms used and not otherwise defined in this Agreement will have the meanings given to them in this Agreement and as defined in this section unless a different meaning clearly applies from the context.

“**AMMP**” means the Fargo-Moorhead Metropolitan Area Flood Risk Management Project Draft Adaptive Management and Mitigation Plan, authored by USACE, which will be periodically updated and amended and incorporated herein.

“**Applicable Law**” means, collectively, the Constitutions of the United States and of the State, all common law and principles of equity, and all Federal, State, and local laws including, without limitation, all environmental laws, statutes, treaties, codes, acts, rules, regulations, guidelines, ordinances, resolutions, orders, judgments, decrees, injunctions, and administrative or judicial precedents or authorities, including the interpretation or administration thereof by any governmental authority charged with the enforcement, interpretation, or administration thereof, all governmental approvals, and all administrative orders, awards, directed duties, requests, licenses, certificates, authorizations, and permits of, and agreements with, any governmental authority, and, with respect to any Person, the articles of incorporation, bylaws, or other organizational or governing documents of such Person, in each case whether or not having the force of law, that are applicable now or are applicable at any time hereafter to the Authority, the County, the AMMP, the Section 404 Permit, or the Forest Mitigation Plan.

“**Authority**” means the Metro Flood Diversion Authority, a political subdivision of the State of North Dakota and a permanent joint powers entity formed through the Joint Powers Agreement to provide the Fargo-Moorhead metropolitan area with permanent and comprehensive flood protection.

“**Authority Representative**” means the individual identified in Section 8.06.

“**Best Efforts**” means that a Party will act in Good Faith, act in accordance with generally accepted commercial practices, and use reasonable due diligence to undertake all action contemplated by this Agreement, in accordance with Applicable Law.

“**Business Day**” means any day that is not a Saturday, a Sunday, or a federal public holiday.

“**Comprehensive Project**” means the Fargo-Moorhead Metropolitan Area Flood Risk Management Project authorized by Section 7002(2) of the Water Resources Reform and Development Act of 2014, as generally described in the Final Feasibility Report and Environmental Impact Statement, Fargo Moorhead Metropolitan Area Flood Risk Management,

dated July 2011 and approved in accordance with the Chief's Report, as amended by the Supplemental Environmental Assessment, Fargo-Moorhead Metropolitan Area Flood Risk Management Project, dated September 2013 and approved by the U.S. Army Engineer, St. Paul, on September 19, 2013, and as amended by the Second Supplemental Environmental Assessment dated August 27, 2018 (2018 SEA), and the Engineering Documentation Report, Fargo-Moorhead Metropolitan Area Flood Risk Management Project, ND and MN, Modifications Through February 2019.

“County” means Cass County, North Dakota, a political subdivision and home rule county of the State of North Dakota.

“County Parcels” means the parcels of real property that are owned by the County and identified on Exhibit A where the Authority will perform forest mitigation in accordance with the terms and conditions of this Agreement for the Comprehensive Project.

“County Representative” means the individual identified in Section 8.06.

“Effective Date” means the date on which both Parties have executed this Agreement.

“Forest Mitigation Plan” means Fargo-Moorhead Metropolitan Area Flood Risk Management Project Forest Mitigation Plan, authored by USACE, which will be periodically updated and amended and incorporated herein.

“Good Faith” means the observance of reasonable commercial standards of fair dealing in a given trade or business.

“Joint Powers Agreement” means the agreement entered into by and between the City of Moorhead, Minnesota; the City of Fargo, North Dakota; Clay County, Minnesota; Cass County, North Dakota; and the Cass County Joint Water Resource District, dated as of June 1, 2016, to create the Authority.

“Non-Federal Sponsors” means the City of Fargo, North Dakota; the City of Moorhead, Minnesota; and the Authority collectively.

“Original Term” means the original term of this Agreement as described in Section 6.01.

“Party” means either the Authority or the County, depending on the context, and its respective successors and assigns, and if a reference is made herein to Parties, **“Parties”** means the Authority and the County collectively and their respective successors and assigns.

“Person” means an individual, a general or limited partnership, a joint venture, a corporation, a limited liability company, a trust, an unincorporated organization, or a governmental authority.

“PPA” means the Project Partnership Agreement, dated July 11, 2016, between the Non-Federal Sponsors and USACE for the construction, operation, and maintenance of the Comprehensive Project

“Section 404 Permit” means Department of the Army Permit, Permit No. NOW-2013-1723-BJS, issued by the Omaha District, North Dakota Regulatory Office, of USACE to the Authority in accordance with Section 404 of the Clean Water Act or 33 U.S.C. § 1344.

“State” means the State of North Dakota.

“USACE” means the United States Army Corps of Engineers.

Section 1.02 INTERPRETATION. The definition of terms in this Agreement will apply equally to the singular and plural forms of the terms defined. Whenever the context may require, any pronoun will include the corresponding masculine, feminine, and neuter forms. The words “include,” “includes,” and “including” will be deemed to be followed by the phrase “without limitation.” Unless the context requires otherwise (a) any definition of or reference to any agreement, instrument, or other document in the Agreement will be construed as referring to the agreement, instrument, or other document as amended, supplemented, or otherwise modified (subject to any restrictions in amendments, supplements, or modifications in the Agreement); (b) any reference in the Agreement to any person will be construed to include the person’s permitted successors and assigns; (c) all references in the Agreement to articles, sections, exhibits, and schedules will be construed to refer to articles and sections of, and exhibits and schedules to, this Agreement; and (e) the word “assets” and “property” will be construed to have the same meaning and effect and to refer to any and all tangible and intangible assets and properties, including cash, securities, accounts, and contract rights.

ARTICLE II. INTENT

Section 2.01 FOREST MITIGATION REQUIREMENTS. The Parties agree and acknowledge that the construction of the Comprehensive Project will result in impacts to forested areas, and as a result, USACE is requiring that the Authority complete forest mitigation in accordance with the Section 404 Permit, the Forest Mitigation Plan, and the AMMP. Following the evaluation of parcels, the County Parcels have been identified as forest mitigation sites, and the County hereby authorizes the Authority to utilize the County Parcels in accordance with the terms and conditions set forth herein for mitigation and adaptive management. The County will execute and record a conservation easement substantially in the form attached hereto as Exhibit D to allow the Authority access to and use of the County Parcels for the purposes set forth in said easement. The bounds of any conservation easement will not come within one hundred (100) feet of the centerline of a County road to provide a buffer zone for future maintenance or expansion on the County road.

Section 2.02 SUBJECT TO CHANGE. The Parties agree and acknowledge that the Section 404 Permit, the Forest Mitigation Plan, and the AMMP may be subject to change per discretion of USACE. In the event the Authority becomes aware of any potential change in any of the above-described documents, the Authority will notify the County in writing. The Authority and the County will thereafter negotiate in Good Faith to determine whether any amendments to this Agreement are warranted.

ARTICLE III. DESIGN AND PLANTING

Section 3.01 DESIGN AND DESIGN STRATEGIES. The Parties agree that each of the County Parcels has undergone an evaluation to determine a forest planting strategy based on opportunity, need, and streambank condition. Planting strategies are generally described in the Forest Mitigation Plan, and the planting strategy or strategies for each County Parcel is included in Exhibit A. The Authority will utilize the respective planting strategy or strategies assigned to each County Parcel, as well as other requirements of the Forest Mitigation Plan, to design how forest mitigation will occur on each site. The Authority will remit a design for each County Parcel to the County Representative for review and approval. The County Representative will respond to the Authority within fourteen (14) calendar days of receipt of a design. If the County Representative does not approve of a design, he or she will provide a written explanation to the Authority outlining the reasons for rejection. The Authority will review the explanation and respond to the County Representative, reworking the design as necessary. The County Representative will review resubmitted work within seven (7) calendar days of receipt. If the County Representative does not respond to the Authority during the above-provided review periods, then the design will be deemed approved by the County.

Section 3.02 SITE PREPARATION. The Authority will complete site preparation on each County Parcel in accordance with the Forest Mitigation Plan. Site preparation may include such actions as clearing and grubbing the identified tree planting area, properly disposing of significant woody debris, treating the site with glyphosate, discing the site to expose mineral soil, and treating the site with an approved pre-emergent herbicide. The Authority will provide reasonable notification to the County prior to conducting any site preparation, which the Parties agree may occur for several years prior to planting.

Section 3.03 MONITORING. The Authority will conduct annual forest monitoring surveys on each County Parcel in accordance with the Forest Mitigation Plan.

ARTICLE IV. MONITORING AND MANAGEMENT

Section 4.01 POST-PLANTING MONITORING. The Authority will perform maintenance and monitoring of the mitigation sites following planting to determine the condition of the habitat types and the overall effectiveness of the mitigation. The Authority will monitor each County Parcel in accordance with the requirements of the AMMP and the Forest Mitigation Plan for five (5) years and then every five (5) years until the objectives of the Forest Mitigation Plan have been fully obtained. If the tree survival rates are less than the Forest Mitigation Plan objectives, then activities may include tree replanting, clearing and grubbing with tree replanting, and treatment with glyphosate and/or pre-emergent herbicide.

Section 4.02 PERFORMANCE STANDARDS. The goal of continuing to monitor the mitigation sites is to ensure that the sites provide the area and quantity needed to offset the loss of forest habitat through footprint impacts. Consequently, the Parties acknowledge that the AMMP and the Forest Mitigation Plan set forth performance standards that the Authority must meet. This may entail that the Authority replant sites and control invasive, noxious, and/or non-native species,

clear and grub with tree planting, and treat with glyphosate and/or pre-emergent herbicide. The Authority will provide the necessary reports regarding its monitoring in accordance with the AMMP and the Forest Mitigation Plan.

Section 4.03 COUNTY RESTRICTIONS. The County agrees to not interfere with the Authority's activities on the County Parcels as set forth in this Agreement, to prevent any activity or use of the County Parcels that is inconsistent with the purpose of this Agreement, and to require the restoration of areas or features that may be damaged by any inconsistent activity or use. In the event that the County transfers its interest in the County Parcels to any other individual or entity, it will notify the individual or entity of the conservation easement on the County Parcel.

ARTICLE V. INDEMNIFICATION

Section 5.01 INDEMNIFICATION. As set forth in the Joint Powers Agreement, the Authority, to the fullest extent authorized by law, shall at all times hereafter, defend and indemnify the County for any liability claims arising from Authority activities or operations, decisions of the Authority, or arising out of or regarding the Comprehensive Project. The Parties agree that the Authority's use of the County Parcels for the activities set forth herein falls within the scope of the indemnification provisions of the Joint Powers Agreement, and, as a result, the Authority will indemnify the County from any and all claims, suits, debts, damages, costs, charges and expenses, including court costs and attorney's fees, and legal fees or disbursements paid or incurred, and against all liability, losses, and damages of any nature whatsoever arising out of the forest mitigation and monitoring activities set forth herein. The indemnity and hold harmless provision, however, shall not be deemed as a waiver by the Authority of the limits of liability set forth in N.D.C.C. § 32-12.1-03, as amended from time to time, or a waiver of any available immunities or defenses. Nothing herein shall be construed to provide insurance coverage or indemnification to any officer, employee, or volunteer of the County for any act or omission for which the officer, employee, or volunteer is guilty of malfeasance in office, willful neglect of duty, or bad faith.

ARTICLE VI. TERM AND TERMINATION

Section 6.01 TERM. This Agreement will have an original term of ten (10) years from the Effective Date (the "Original Term") and shall automatically renew for subsequent renewal terms of ten (10) years (a "Subsequent Renewal Term") unless terminated in accordance with this Agreement.

Section 6.02 TERMINATION. The Parties may mutually agree to terminate this Agreement prior to the expiration of the Original Term or a Subsequent Renewal Term; provided, however, the Conservation Easement will remain in place following the termination of this Agreement.

ARTICLE VII. DISPUTE RESOLUTION

Section 7.01 INTENT AND PROCEDURE. The Parties will cooperate and use their Best Efforts to ensure that the various provisions of this Agreement are fulfilled. The Parties agree to act in Good Faith to undertake resolution of disputes in an equitable and timely manner and in accordance with the provisions of this Agreement. If disputes cannot be resolved informally by the Parties, the following procedure will be used.

Section 7.02 MEDIATION. If there is a failure between the Parties to resolve a dispute on their own, the Parties will first attempt to mediate the dispute. The Parties will agree upon a single mediator or, if an agreement cannot be reached within ten (10) calendar days, the mediator shall be selected by the American Arbitration Association (“AAA”) in accordance with its Commercial Industry Mediation Rules and Procedures then in effect.

Section 7.03 LITIGATION. If the dispute is not resolved within forty-five (45) calendar days after the selection of the mediator pursuant to the preceding section, the Parties may litigate the matter.

Section 7.04 VENUE. All litigation between the Parties arising out of or pertaining to this Agreement or its breach will be filed, heard, and decided in the District Court of Cass County, North Dakota, which will have exclusive jurisdiction and venue.

Section 7.05 WAIVER OF JURY TRIAL. THE PARTIES HEREBY KNOWINGLY, IRREVOCABLY, VOLUNTARILY, AND INTENTIONALLY WAIVE ANY RIGHTS THAT EITHER MAY HAVE TO A TRIAL BY JURY WITH RESPECT TO ANY ACTION, PROCEEDING, COUNTERCLAIM, OR DEFENSE BASED ON THIS AGREEMENT, OR ARISING OUT OF, UNDER, OR IN ANY CONNECTION WITH THIS AGREEMENT, OR WITH RESPECT TO ANY COURSE OF CONDUCT, COURSE OF DEALING, STATEMENTS (WHETHER ORAL OR WRITTEN), OR ACTIONS OF ANY PARTY HERETO RELATING TO THIS AGREEMENT. THIS PROVISION IS A MATERIAL INDUCEMENT FOR ALL PARTIES ENTERING INTO THIS AGREEMENT. THIS PROVISION APPLIES ONLY TO SUITS BETWEEN THE PARTIES AND DOES NOT APPLY TO THIRD PARTY CLAIMS OR SUITS.

ARTICLE VIII. MISCELLANEOUS

Section 8.01 COMPLETE AGREEMENT. This Agreement contains the entire and exclusive understanding of the Parties with respect to the subject matter thereof and supersedes all prior agreements, understandings, statements, representations, and negotiations, in each case oral or written, between the Parties with respect to their subject matter.

Section 8.02 COUNTERPARTS. This instrument may be executed in two or more counterparts, each of which will be deemed an original, but all of which together will constitute one and the same instrument.

Section 8.03 AMENDMENTS. This Agreement may be amended only by written instrument duly executed by the Parties or their respective successors or assigns, except to the extent expressly provided otherwise in this Agreement.

Section 8.04 SEVERABILITY AND SAVINGS CLAUSE. Each provision, section, sentence, clause, phrase, and word of this Agreement is intended to be severable. If any provision, section, sentence, clause, phrase, or word hereof is held by a court of competent jurisdiction to be illegal or invalid for any reason whatsoever, such illegality or invalidity will not affect the validity of the remainder of this Agreement.

Section 8.05 FORCE MAJEURE. No Party will be liable to another Party during any period in which its performance is delayed or prevented, in whole or in part, by circumstances beyond its reasonable control. Circumstances include, but are not limited to, the following: act of God (e.g., flood, earthquake, wind), fire, war, act of a public enemy or terrorist, act of sabotage, strike or other labor dispute, riot, misadventure of the sea, inability to secure materials and/or transportation, or a restriction imposed by legislation, an order, or a rule or regulation of a governmental entity. If such a circumstance occurs, the Party claiming the delay must undertake reasonable action to notify the other Parties of the same.

Section 8.06 AUTHORIZED REPRESENTATIVES. The Authority and the County hereby designate the following individuals as their initial authorized representatives, respectively, to administer this Agreement on their respective behalf:

- (a) Authority Representative: Jodi Smith, Director of Lands
- (b) County Representative: Jason Benson, County Engineer

Section 8.07 NOTICE.

(a) All notices under the Agreement will be in writing and: (i) delivered personally; (ii) sent by certified mail, return receipt requested; (iii) sent by a recognized overnight mail or courier service, with delivery receipt requested; or (iv) sent by email communication followed by a hard copy, to the following addresses.

(b) All notices to the Authority will be marked as regarding forest mitigation and will be delivered to the following address or as otherwise directed by the Authority Representative:

4784 Amber Valley Parkway South, Suite 100
Fargo, North Dakota 58104

(c) All notices to the County will be marked as regarding forest mitigation and will be delivered to the following address or as otherwise directed by the County Representative:

1201 Main Avenue West
West Fargo, North Dakota 58078

(d) Notices will be deemed received when actually received in the office of the addressee (or by the addressee if personally delivered) or when delivery is refused, as shown on the receipt of the U.S. Postal Service, private courier, or other person making the delivery.

Notwithstanding the foregoing, notices received after 5:00 p.m. Central Time will be deemed received on the first Business Day following delivery.

Section 8.08 GOVERNING LAW. This Agreement will be governed by and construed in accordance with the laws of the State of North Dakota.

Section 8.09 CONFLICT WITH OTHER MOU. Nothing in this Agreement is intended to supersede, amend, or otherwise modify any other memorandum of understanding or agreement entered by and between the Authority and the County for work regarding other aspects of the Comprehensive Project.

Section 8.10 CONFLICT WITH JOINT POWERS AGREEMENT. Nothing in this Agreement is intended to conflict with the provisions of the Joint Powers Agreement. In the event there is a conflict, the provisions of the Joint Powers Agreement will control.

Section 8.11 ELECTRONIC SIGNATURES. The Authority and the County agree that an electronic signature on this Agreement shall be valid as an original signature of the Authority or the County and shall be effective to bind the signatories of this Agreement.

IN WITNESS WHEREOF, the Authority and the County caused this Agreement to be executed.

(Remainder of page intentionally left blank.)

Signature Page for the Metro Flood Diversion Authority

The governing body of the Metro Flood Diversion Authority approved this Agreement on the ____ day of _____, 2023.

METRO FLOOD DIVERSION
AUTHORITY

By: _____
Dr. Timothy J. Mahoney, Chair

By: _____
Joel Paulsen, Executive Director

ATTEST:

By: _____
Dawn Lindblom, Secretary

Signature Page for Cass County, North Dakota

The governing body of Cass County, North Dakota, approved this Agreement on the ____ day of _____, 2023.

CASS COUNTY, NORTH DAKOTA

By: _____
Chad M. Peterson, Chairman of the
Board of County Commissioners

ATTEST:

Brandy Madrigga, Finance Director

EXHIBIT A

County Parcel List and Map

<i>Parcel PIN</i>	<i>Parcel OIN</i>
57-0000-10206-020	9409
57-0000-10208-010	810
57-0000-10208-020	811
57-0400-00010-000	9432
57-0400-00020-000	9439
57-0400-00060-000	9997
57-0400-00070-000	9996
57-0400-00170-000	9428
57-0400-00180-000	9429
57-0400-00190-000	9430
57-0400-00200-000	9437
57-0600-00060-000	9424
64-0000-02281-010	1060
64-0000-02370-010	5244
64-0000-02371-000	7245
78-0010-00750-000	9610
78-0010-00740-000	9611
78-0010-00720-010	9612
78-0010-00710-000	9613
78-0010-00640-010	9621
78-0010-00580-000	9627
78-0010-00560-000	9629
78-0010-00550-000	9630
78-0010-00500-000	9636
78-0010-00501-000	9637
78-0010-00480-000	9639
78-0010-00475-000	9640

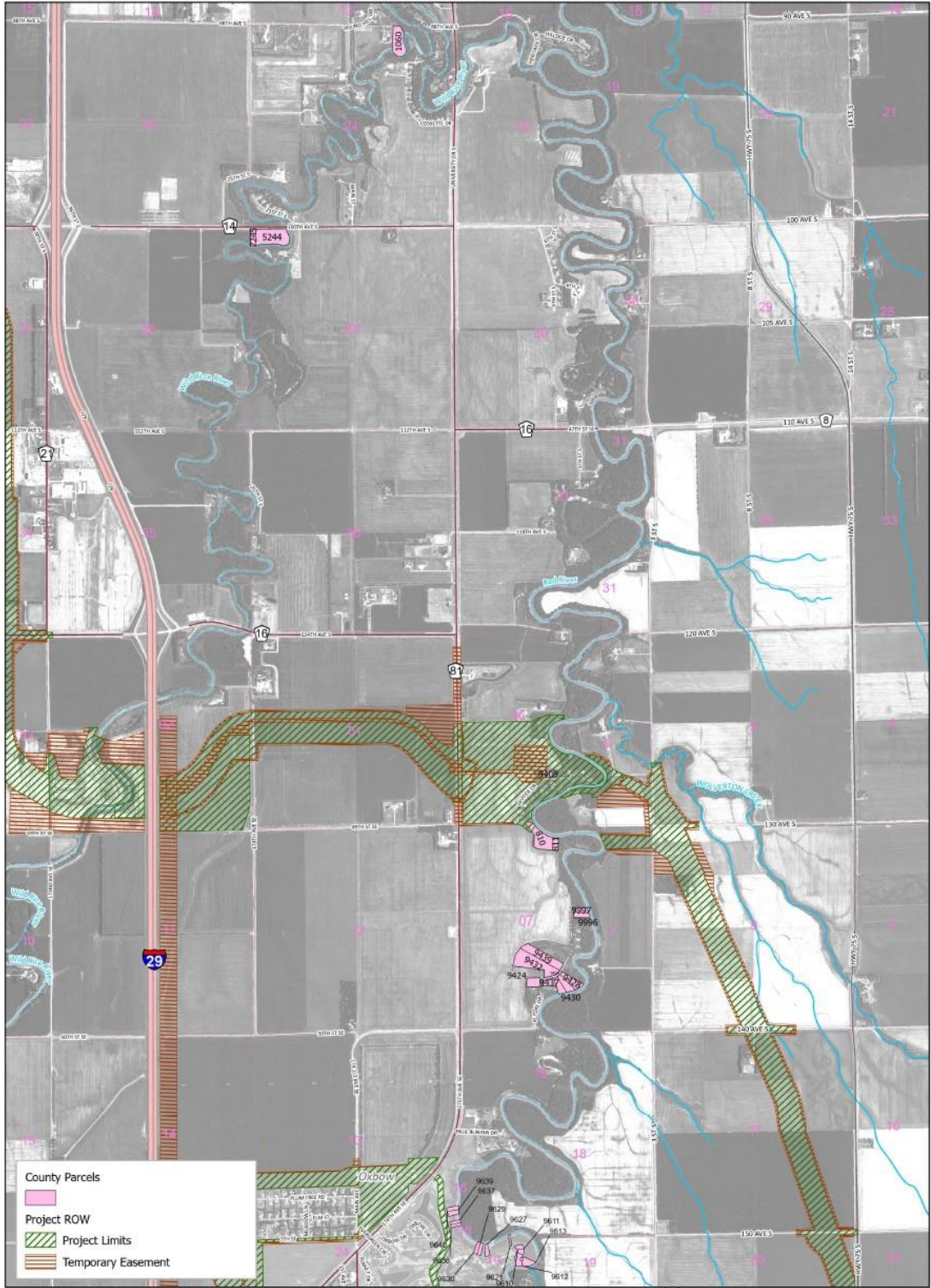

Any reliance upon this map is at user's own risk. AE2S does not warrant the map or its features are either spatially or temporally accurate or fit for a particular use. All parcel acreages and legal descriptions shown herein are based on County GIS data. Final acreages and legal descriptions to be determined by boundary survey. Coordinate System: NAD 1983 StatePlane North Dakota South FIPS 3302 Feet | Edited by: cwickenheiser\C\Data\Projects\GIS Projects\FM Area Diversion\012 Lands Program\Mitigation Planning\Forest Mitigation\FMDiversion_ForestMitigation_v2_forCounty.aprx | OHB_Area

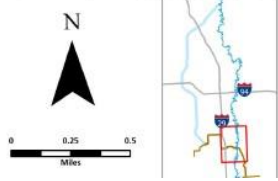

**FOREST MITIGATION AGREEMENT
 (VERSION 3)
 EXHIBIT A**

FM AREA DIVERSION PROJECT
 Map Date: 1/4/2024



EXHIBIT B

Current Version of AMMP

(See the following pages.)

EXHIBIT C

Current Version of Forest Mitigation Plan

(See the following pages.)

EXHIBIT D

Draft Conservation Easement

PERMANENT CONSERVATION EASEMENT

THIS EASEMENT is made this ____ day of _____, 20____, between the Metro Flood Diversion Authority, a political subdivision of the State of North Dakota with a mailing address of 4784 Amber Valley Parkway South, Suite 100, Fargo, North Dakota 58104 (the “Authority”), and Cass County, North Dakota, a political subdivision of the State of North Dakota, with a mailing address of 1201 Main Avenue West, West Fargo, North Dakota 58078 (the “Landowner”), who together agree as follows:

RECITALS

A. The Authority, a permanent joint powers entity, is the non-federal sponsor responsible for delivering the Fargo-Moorhead Metropolitan Area Flood Risk Management Project (the “Comprehensive Project”); and

B. The United States Army Corps of Engineers (“USACE”) granted a permit to the Authority under Section 404 of the Clean Water Act (the “Section 404 Permit”) for those portions of the Comprehensive Project that are the responsibility of the non-federal sponsors; and

C. The Section 404 Permit requires the Authority to undertake forest compensatory mitigation and adaptive monitoring and mitigation (the “Project”) due to impacts resulting from those portions of the Comprehensive Project that are the responsibility of the non-federal sponsors; and

D. The Landowner owns certain real property necessary for the Project and agrees to convey a Permanent Easement to the Authority upon, in, on, under, over, across, and through the property described below, all subject to the terms and conditions contained in this Easement.

In consideration of \$10.00, the mutual covenants contained in this Permanent Easement, and other good and valuable consideration, the receipt and sufficiency of which the parties acknowledge, the parties agree as follows:

AGREEMENT

1. Permanent Easement Property. The Landowner grants and conveys to the Authority a Permanent Easement, including the easement rights described in this Permanent Easement, upon, over, in, on, under, across, and through the following real property in Cass County, North Dakota:

[PROPERTY DESCRIPTION]

(the “Permanent Easement Property”).

2. Permanent Easement. Under this Permanent Easement, the Landowner grants to the Authority, its officers, employees, agents, representatives, and contractors, a permanent and perpetual easement in, on, over, under, across, and through the Easement Property for the following purposes: constructing, cleaning, inspecting, reconstructing, restoring, modifying, managing, maintaining, repairing, and improving the Project; excavating, piling, storing, depositing, spoiling, spreading, and removing excavated dirt, soil, clay, silt, gravel, rock, or other materials; moving, storing, and removing equipment, materials, and supplies; planting trees, shrubs, and other vegetation; removing trees, underbrush, noxious weeds, obstructions, and any other vegetation, structures, or obstacles from the Easement Property; and the right to perform any other work necessary and incident to the construction, cleaning, inspecting, reconstructing, restoring, modifying, managing, maintaining, repairing, or improvement of the Project, together with all necessary and reasonable rights of ingress and egress to and from the Easement Property. Additionally, the Landowner grants to the Authority, its officers, employees, agents, representatives, and contractors the ability to prevent any future development, construction, or use that would negatively impair or interfere with the Project. The Authority is not responsible for pre-existing environmental contamination or liabilities.

3. Consideration. The Landowner specifically acknowledges the consideration received by the Landowner represents full and final consideration to the Landowner as compensation or damages regarding the Permanent Easement Property, any of the Landowner’s remaining property, or the Project, and that the Landowner is not entitled to any further payments, tax reductions, or damages under any state or federal statute, constitutional provision, rule, or regulation, or other legal authority.

4. Easement Runs With the Permanent Easement Property. This Permanent Easement, and all covenants, terms, conditions, provisions, and undertakings created under this Permanent Easement, are perpetual and will run with the Permanent Easement Property, and will be binding upon the Landowner’s heirs, successors, and assigns.

5. Structures and Personal Property. Any buildings, structures, fixtures, personal property, or other items remaining on the Permanent Easement Property will automatically become the Authority’s property upon execution of this Permanent Easement, without the need for any bill of sale or any other written instrument or agreement. The Authority may then remove any buildings, structures, personal property, or other items from the Permanent Easement Property, at its sole discretion and at its sole cost.

6. Taxes. The Landowner is solely responsible for all taxes and special assessments or assessments for special improvements due, levied, or assessed regarding the Permanent Easement Property for all past, present, and future years. The Authority will not be responsible for payment of any real estate taxes or special assessments regarding the Permanent Easement Property.

7. Landowner’s Use of Permanent Easement Property.

A. The Landowner has the right and privilege to use the Permanent Easement Property at any time, in any manner, and for any purpose that is not inconsistent with the Authority's rights and privileges under this Permanent Easement. The Landowner will not use, or permit use of, the Permanent Easement Property in any manner that disrupts or interferes with the Authority's use of the Permanent Easement Property, the Authority's rights and privileges under this Permanent Easement, or with the Project. The Landowner will promptly cease any activities and remove any structures or obstructions that interfere with the Authority's use of the Permanent Easement Property, the Authority's rights and privileges under this Permanent Easement, or with the Project, when directed by the Authority, at the Landowner's sole cost. The Landowner will repair or replace any of any of the Authority's structures, trees, vegetation, right of way, or any other property owned by the Authority damaged by the Landowner or the Landowner's agents or as a result of the Landowner's use or the Landowner's agent's use of the Permanent Easement Property, at the Landowner's sole cost.

B. For purposes of this section and for the sake of clarity, the following is a non-exhaustive list of uses that are inconsistent with the Authority's rights and privileges under this Permanent Easement:

- (1) Constructing or placing structures or mobile homes, fences, signs, billboards, or other advertising material, or other structures, whether temporary or permanent;
- (2) Filling, draining, excavating, mining, drilling, or removing topsoil, loam, peat, sand, gravel, rock, minerals, or other materials;
- (3) Building of roads or paths for vehicular or pedestrian travel or any change in the topography of the land;
- (4) Removing, destructing, or cutting of trees or plants;
- (5) Spraying with biocides, insecticides, or pesticides;
- (6) Grazing of animals, farming, tilling of soil, or any other agricultural activity; and
- (7) Operating all-terrain vehicles or any other type of motorized vehicle.

8. Encumbrances. The Landowner will not encumber the Permanent Easement Property or enroll the Permanent Easement Property in any program that would be contrary to, or would in any way disrupt or interfere with, the Authority's use of the Permanent Easement Property, the Authority's rights and privileges under this Permanent Easement, or the Project.

9. Waiver of Warranties. The parties specifically agree neither the Landowner nor any of its agents or representatives have made any representations or warranties in any way regarding the Project; the Landowner's ability to use the Permanent Easement Property following

construction of the Project; or the Landowner's ability to enroll the Permanent Easement Property in any federal program.

10. Forbearance or Waiver. The failure or delay of the Authority to insist on the timely performance of any of the terms of this Permanent Easement, or the waiver of any particular breach of any of the terms of this Permanent Easement, at any time, will not be construed as a continuing waiver of those terms or any subsequent breach, and all terms will continue and remain in full force and effect as if no forbearance or waiver had occurred.

11. Governing Law. This Permanent Easement will be construed and enforced in accordance with North Dakota law. The parties agree any litigation arising out of this Permanent Easement will be venued in State District Court in Cass County, North Dakota, and the parties waive any objection to venue or personal jurisdiction.

12. Severability. If any court of competent jurisdiction finds any provision or part of this Permanent Easement is invalid, illegal, or unenforceable, that portion will be deemed severed from this Permanent Easement, and all remaining terms and provisions of this Permanent Easement will remain binding and enforceable.

13. Entire Agreement. This Permanent Easement, together with any amendments, and the Forest Mitigation Agreement, dated _____, entered between the parties (the "Agreement"), contains the entire agreement between the parties regarding the matters described in this Permanent Easement, and this Permanent Easement and the Agreement supersede all other previous oral or written agreements between the parties regarding the Project.

14. Modifications. Any modifications or amendments of this Permanent Easement must be in writing and signed by the Landowner and the Authority and must be recorded in the Cass County Recorder's Office.

15. Representation. The parties, having been represented by counsel or having waived the right to counsel, have carefully read and understand the contents of this Permanent Easement, and agree they have not been influenced by any representations or statements made by any other parties.

16. Headings. Headings in this Permanent Easement are for convenience only and will not be used to interpret or construe its provisions.

(Signatures appear on the following pages.)

DRAFT

Fargo-Moorhead Metropolitan Area Flood Risk Management Project

Forest Mitigation Plan



Oxbow Country Club Mitigation, Fall 2021

April 2023

(This page left intentionally blank)

DRAFT

Fargo-Moorhead Metropolitan Area Flood Risk Management Project

Forest Mitigation Plan

Contents

1.	Background.....	1
2.	Document Purpose	1
3.	Determination of Mitigation Needs & Objectives.....	1
4.	Forest Planting Strategies	2
4.1	Bank Stabilization.....	2
4.2	Floodplain Forest	3
4.3	Oak Savanna	3
5.	Site Preparation / Initial Work	4
6.	Forest Mitigation Site Selection	5
6.1	Baseline Information	5
6.2	Description of Potential Forest Mitigation Sites	6
6.3	Site Summary	13
7.	Monitoring & Management.....	16
7.1	Monitoring Requirements.....	16
7.2	Monitoring Reports.....	16
7.3	Performance Standards.....	17
7.3.1	Bank Stabilization.....	17
7.3.2	Floodplain Forest	18
7.3.3	Oak Savannah.....	18
7.3.4	Invasive Species.....	19
7.4	Long-term Management Plan	19
7.5	Adaptive Management Plan.....	19
7.6	Site Protection Instrument	19
7.7	Financial Assurance.....	19

Fargo-Moorhead Metropolitan Area Flood Risk Management Project

Forest Mitigation Plan

April 2023

1. Background

The US Army Corps of Engineers (Corps) Civil Works Program mitigates for all significant resources adversely affected by Corps projects. For the Fargo Moorhead Metropolitan Area Flood Risk Management Project (FMM Project) this includes impacts to riparian, floodplain, and upland forest areas.

The current Project design is expected to result in approximately 148.7 acres of forest impacts. These impacted forest areas are composed of mostly floodplain forests, shelterbelts, and wooded groves near building sites.

2. Document Purpose

This document addresses the mitigation requirements for all forest impacts associated with the construction of the FMM Project. The document identifies forest mitigation sites, planting strategies, monitoring requirements, performance standards, and long-term management goals. The Fargo-Moorhead Metropolitan Area Flood Risk Management Project Forest Mitigation Plan (FMM Forest Mitigation Plan) is a living document and will be updated if additional forest impacts due to the Project occur, or if additional opportunities for forest mitigation arise. Changes to the FMM Forest Mitigation Plan would require consensus recommendation from the Forest Management Team and the Adaptive Management Team, using the process described in the Adaptive Management and Mitigation Plan (AMMP) for the Project.

3. Determination of Mitigation Needs & Objectives

As described in the AMMP, some forested areas would need to be cleared for construction of the Project. Forested areas impacted by construction of Project features total 148.7 acres for the current design. The Feasibility Report and Environmental Impact Statement (EIS) outlined a habitat evaluation process for existing floodplain forest in the Project area, which identified a habitat suitability factor of 0.51. This suitability factor is assumed to not have changed as no major changes have occurred in the area related to forest composition or structure that would result in appreciable alteration of that suitability factor. Thus, 0.51 is applied to the acres impacted to identify the habitat units for lost forest habitat and the targeted amount for mitigation.

In terms of habitat conditions over the next 50 years, woodland extent, structure, and composition is assumed to remain fairly similar to existing conditions. While habitat value for individual species may change over time as natural setback/succession processes occur on

these established tracts, the overall habitat value for the riparian woodland community would remain essentially the same and be rated as fair with a HSI of 0.51.

The assumed HSI for an established floodplain forest is 0.51. It is also assumed that it could take a full 50 years for a created forest to reach its full functioning level. Over a 50-year planning horizon (the standard for the Corps planning activities), assuming a starting HSI of 0 and an ending HSI of 0.51, would amount to an average HSI value of 0.25. Thus, approximately 303.2 acres of floodplain forest habitat would be needed to generate the 75.8 Habitat Units of mitigation needed to offset the 148.7 acres of forest impacts.

FMM Project impacts will occur in both North Dakota and Minnesota. Mitigation in each state will be proportional to the number of impacts resulting from construction. A summary of forest impacts and the required mitigation can be found in the following table (Table 1).

Table 1. Forest Impacts and Mitigation Needs

Impact	Footprint Area Lost (ac)		Existing Habitat Quality Score	Habitat Units Lost		Created Forest Habitat Quality Score	Mitigation Needs (ac)	
	ND	MN		ND	MN		ND	MN
Forest	132.8	15.9	0.51	67.7	8.1	0.25	270.8	32.4
Total	148.7		0.51	75.8		0.25	303.2	

It is uncertain what portion of the forests identified could be classified as forested wetland; however, all forest impacts would be mitigated for by converting former building sites and farm fields adjacent to rivers into forested habitat; utilizing three primary strategies: planting of floodplain forest community with a combination of bare-root and container tree stock; planting and seeding Oak-Savanna habitat; and utilizing willow, cottonwood, and sumac for streambank stabilization. Each planting strategy is detailed below.

4. Forest Planting Strategies

Three distinct types of reforestation strategies were developed to address the variability in the project sites. Some sites currently have streambank erosion issues that could be stabilized by planting species that develop dense root systems, some sites have elevations suitable for floodplain forest reforestation, and other sites have elevations that lend themselves to recreating Oak Savanna habitat. Planting will be adapted to the topography at each site but minor grading and earth moving may occur to enhance plantings or to provide adequate drainage. These strategies or prescriptions were developed site by site to suit each location individually, based on opportunity, need, and streambank condition.

4.1 Bank Stabilization

Bank stabilization along the streambanks shall be accomplished with a combination of live stake plantings and riparian tree plantings along with an herbaceous seed mix for stabilization. Live stakes are utilized best closer to the water, as the live stakes need contact with the water table for success. Live stake species can consist of willow (*Salix spp.*), red-osier dogwood (*Cornus*

sericea) and eastern cottonwood (*Populus deltoides*). Farther away from the waterline, and closer to the habitat transition zone, planting bare-root seedlings of peachleaf willow (*Salix amygdaloides*), sandbar willow (*Salix interior*), Smooth sumac (*Rhus glabra*), and plains cottonwood (*Populus deltoides monilifera*) will be utilized.

The live stake work shall consist of inserting live, woody, rootable plant cuttings into streambanks and encouraging their growth as described in the Live Stakes Construction guidelines (Appendix B). When properly utilized, the binding root mass of the mature shrubs and/or trees will ultimately stabilize and reinforce the soil. If any riverbanks slopes are degraded beyond a moderate slope of 4:1, excavation and grading dirt work should first be considered to repair the bank back to an acceptable slope. Immediately following the completion of any dirt work, disturbed area will be stabilized and seeded with an appropriate vegetation mix, such as MN BWSR riparian S&W 34-262 (Appendix A).

4.2 Floodplain Forest

Planting the sites with bare-root seedlings and container trees has been found to be the most effective way to restore floodplain forest in this region. The work would include woody debris removal, disking, herbicide treatment, and planting bare-root seedlings of plains cottonwood (*Populus deltoides monilifera*), peachleaf willow (*Salix amygdaloides*), boxelder (*Acer negundo*), hackberry (*Celtis occidentalis*), quaking aspen (*Populus tremuloides*), silver maple (*Acer saccharinum*), black walnut (*Juglans nigra*) and American basswood (*Tilia americana*). Hard mast species would involve planting bur oak (*Quercus macrocarpa*) container trees. Container and bare root seedlings should be planted at a rate of 550 trees per acre with a 9x9 spacing. Rows should follow the contour of the terrain, if the site is flat rows should meander in a way that looks natural. Up to 20% of the site should also include native shrub species interspersed throughout each site from the following list of species: chokecherry (*Prunus virginiana*), redosier dogwood (*Cornus stolonifera*), American hazelnut (*Corylus americana*), juneberry (*Amelanchier alnifolia*), American plum (*Prunus americana*), smooth sumac (*Rhus glabra*), pin cherry (*Prunus pensylvanica*), common snowberry (*Symphoricarpos albus*), American cranberrybush (*Viburnum trilobum*).

Monitoring would be conducted, and additional seedlings would be planted if the tree density targets are not attained. No one species shall make up more than 20% of the initial planting stock.

4.3 Oak Savanna

The Oak Savanna sites will consist of bur oak (*Quercus macrocarpa*) container and bare root seedlings planted at a minimum rate of 300 trees per acre with a 6x6 spacing in several dense aggregates and individual trees interspersed throughout the site. Tree cover should be at least 10 percent but no more than 50 percent cover of any field. Inclusion of bur oak bare root stock planting is encouraged to buffer for mortality of planted trees and increase the chance of successful mitigation. This will allow for some parts of the savanna to be more open (greater spacing or “openings”) than other parts and create a more natural appearance.

Due to the openness that defines oak savannas, the grasses and other herbaceous vegetation are a critical component to a successful site. Open areas will be planted utilizing the Woodland Edge South & West seed mix (Appendix A) at the minimum rates prescribed.

5. Site Preparation / Initial Work

The following initial work should be considered for all site preparation work:

1. Delineate tree planting areas:
 - a. For Floodplain Forest, tree and shrub planting areas need to cover at least 80 percent of total area. The remaining 20 percent of the mitigation area would be seeded with native forbs and grasses germinated from locally grown propagules. These areas of local vegetation would be interspersed between the tree planting areas.
 - b. For Oak Savannah, tree planting areas should be in clusters to cover between 10 and 50 percent of total site area. The remaining area would be seeded with the Woodland Edge South & West seed mix.
2. Clear and grub the identified tree planting area and properly dispose of significant woody debris if necessary.
3. Treat the site with glyphosate after spring green-up and again in early fall to clear the site of any competing vegetation.
4. If soil prep is needed, disc the site to expose mineral soil and treat with an approved pre-emergent herbicide if disking in the spring. If a fallow period is expected, incorporation of an annual cover crop of annual oats (*Avena sativa*) or winter wheat (*Triticum aestivum*) will be planted on exposed soil to aid in stabilization and weed suppression until a target species planting occurs.
5. Plant each respective planting zone with their respective bare-root seedlings and bur oak container trees. Bare-root seedlings will be planted using a planting machine in meandering rows to better imitate a natural forest. Container seedlings will be planted by hand in the same rows as the bare root seedlings. All bur oak trees planted will require grow-tubes and a support stake large enough to keep the tree upright immediately following planting.
6. Assuming good growth, spot spraying an approved and appropriate herbicide in the fall after the seedlings go dormant to help ensure that there would be minimal weed problems during the following growing season trees in the second growing season if necessary.
7. If the bare-root seedlings are not successful per performance standards listed in this document, re-plant seedlings and install grow-tubes and a support stake large enough to keep the tree upright immediately after planting.
8. If bur oak container trees are not successful performance standards listed in this document, re-plant container tubes and install grow-tubes and support stakes large enough to keep the tree upright immediately after planting.
9. If necessary, removal of grow tubes and support stakes when the tree exceeds tube height and tree can self-support without the tree tube for upright growth.

10. Monitoring areas seeded with herbaceous vegetation will be completed annually, for up to five years, following the performance standards presented in this document.
11. If necessary, utilization of prescribed burning, as appropriate, can be used as management tool once full site establishment is complete.

6. Forest Mitigation Site Selection

Forest mitigation sites will be located in the Red River of the North watershed, the same watershed where the impacts will occur. Input from partnering agencies and the non-federal sponsors have helped to develop criteria to aid in site selection. Site selection is prioritized by lands that have been acquired by the non-federal sponsors, sites that would result in large contiguous blocks of forest, sites adjacent to rivers and streams, sites where wetland hydrology could be restored or improved, and sites that are adjacent to other forested or natural areas. Lands that become inaccessible or difficult to utilize due to the construction of Project features will also be given additional consideration.

The Oxbow-Hickson-Bakke (OHB) Site was identified in the Forest Mitigation Plan dated April 2016. Since then, the OHB Site has been planted and an additional site immediately to the north, known as the Oxbow Country Club Restoration Project (WP43.G) has also been constructed. The OHB Site and Oxbow Country Club Restoration will result in 13 and 63 acres of new forest, respectively in North Dakota.

The identified sites and their reforestation prescriptions below are designed to fulfill the remaining required forested acreage. Sites considered for forest planting are assigned a site number for identification purposes. Sites are evaluated for adequacy for forest mitigation by the Forest Management Team. Sites that receive a favorable consensus rating from the group are added to the Forest Mitigation Plan, while others are removed from consideration.

6.1 Baseline Information

Numerous sites have been identified for potential forest mitigation throughout the project area. The sites are located along rivers and are often connecting existing forested riparian areas. The majority of the sites are currently used in the production of agricultural row crops or were once building sites. Unless specifically called out otherwise, all agricultural fields would continue to be planted with row crops until trees are planted to suppress weeds and undesirable vegetation from establishing. All buildings, foundations, and debris would be removed from the mitigation sites. Sites with undesirable vegetation would be treated with broad-spectrum herbicide, such as glyphosate, to clear the area prior to planting with trees and other natural vegetation.

6.2 Description of Potential Forest Mitigation Sites

Corresponding imagery of each site can be found in the attached map book, FMM Forest Mitigation Mapbook (Appendix D), located at the end of this document.

OHB Site:

The OHB (Oxbow-Hickson-Bakke) Site is located adjacent to the Red River of the North, south of the City of Oxbow in Cass County, North Dakota. The site is located east of the recently constructed oxbow levee and adjacent to an existing floodplain forest. The site encompasses approximately 13 acres and is located on the unprotected side of the Oxbow Hickson Bakke Levee. The site was in use for agricultural row crops from at least 1990 until 2014 when a levee was constructed immediately west of the site and agricultural activities ceased. The site is bordered on the east and north by a floodplain forest adjacent to the Red River of the North and to the west by the recently constructed levee. The site is comprised of two soil types. The most abundant is Sinai silty clay (I475B) which is described as being found on 0-6% slopes. The major component (80%) is listed as Sinai, which is a well-drained, non-hydric, clayey soil. The second most abundant soil is Cashel silty clay (I293B), which is found in 0-6% slopes and occasionally flooded. The major soil component (80%) is Cashel, a loamy overflow that is non-hydric, but somewhat poorly drained.

Agricultural production ceased on this parcel and it began regenerating naturally from propagules provided by the adjacent floodplain forest. The majority of the seedlings were box elder (*Acer negundo*). The site was planted in 2016 with inner plant bare root stock or potted stock to provide additional diversity. Species of the initial planting included 5 native species (potted stock): Silver maple (*Acer saccharinum*), bur oak (*Quercus macrocarpa*), Eastern cottonwood (*Populus deltoids*), hackberry (*Celtis occidentalis*), and redosier dogwood (*Cornus sericea*).

Oxbow Country Club Site:

This site is located immediately adjacent to the Red River of the North and measures approximately 63 acres. A large portion of this site is located within the 10-year flood inundation boundary. It is primarily comprised of Cashel silty clay (I293B), which is found in 0-6% slopes and occasionally flooded. The major soil component (80%) is Cashel, a loamy overflow that is non-hydric, but somewhat poorly drained. The remaining portion of the site is comprised of Wahpeton silty clay (I451D), which is found on 1-15% slopes and occasionally flooded. The major components are listed as Wahpeton (35%), which is a moderately well drained, non-hydric clayey soil, and Cashel (25%), a somewhat poorly drained, non-hydric loamy overflow soil.

The total area of tree planting which shall be considered Floodplain Forest is just over 63 acres, and includes the following species: Cottonwood, Green Ash, Hackberry, Bur Oak, American elm, Silver maple, American basswood, and Quaking Aspen, as described in the OHB Ring Levee Wetland Mitigation Plan WP43.G. This site was planted in 2022 with 57.38 acres of bare-root seedlings and 5.68 acres of experimental direct seeding. Both are intended to provide 300 individuals per acre after the first year of establishment. On the higher ground in the center of the site bare-root seedlings were planted amongst existing trees. Tree and shrub planting was

not allowed within 20 feet from the toe of the levee to allow for the minimum 15-foot Vegetation-Free Zone. Other areas on the site are intended to provide wetland mitigation and were planted with wetland seed mixes.

Site 1 – OIN 1222:

This site is located immediately adjacent to the Red River of the North and measures approximately 12.9 acres. It is currently in agricultural production and a cursory review of aerial imagery shows agriculture use for at least the last 30 years. The majority of this site, approximately 80% is located within the 10-year flood inundation boundary. It is comprised entirely of Cashel silty clay (I293B), which is found in 0-6% slopes and occasionally flooded. The major soil component (80%) is Cashel, a loamy overflow that is non-hydric, but somewhat poorly drained. This is a high priority site for floodplain forest re-establishment, and after reforestation, would expand existing riparian buffer habitat in the Red River system. This site would be reforested using the Floodplain Forest strategy (green polygon) across the entire site. June 2022 Site Visit notes described the site as currently in agricultural production with soybeans the present crop. Ash, Elm, Box Elder, Willow, and a few scattered Bur Oaks were observed in the surrounding forested area. Some reed canary grass was observed around the south and southwestern perimeter that would need to be addressed should this site be utilized.

Site 5 - OIN 922:

This site is located adjacent to the Maple River and measures approximately 2.8 acres. A cursory review of aerial imagery shows that this site has been in agricultural production for at least several decades. The portion of the site identified for bank stabilization falls within the 10-year flood inundation boundary, and the majority of the site is comprised of Wahpeton silty clay (I248A), which is described as being found on 0-2% slopes and occasionally flooded. The major component (70%) is listed as Wahpeton, which is a moderately well drained, non-hydric clayey soil. The site does show a swale with Fargo silty clay (I235A), that is typically depressional in 0-1% slopes, with Fargo being its major component (75%). Fargo is described as a clayey, poorly drained, hydric soil. Although this is a smaller property, it would provide additional riparian buffer benefits to the Maple River. This site would be planted similar to Site 6 in which the sloped areas adjacent to the river would be planted using the Bank Stabilization strategy (orange polygon, approx. 0.5 acres) and transition into Floodplain Forest strategy (green polygon, approx. 2.2 acres) as the elevation rises, farther from the river.

Site 6 – OIN 923Y:

This site is located adjacent to the Maple River and measures approximately 21.3 acres. A cursory review of aerial imagery shows that this site has been in agricultural production for at least several decades. The majority of the site is comprised of Wahpeton silty clay (I248A), which is described as being found on 0-2% slopes and occasionally flooded. The major component (70%) is listed as Wahpeton, which is a moderately well drained, non-hydric clayey soil. The northern portion of the site shows Fargo silty clay (I229A), found on 0-1% slopes, with Fargo being its major component (80%). Fargo is described as a clayey, poorly drained, hydric soil. This is a larger site and would provide much needed riparian buffer benefits to the Maple River. The entire site would be planted with the Floodplain Forest strategy (green polygon).

Site 10:

This site is located immediately adjacent to the Red River of the North and measures approximately 14.8 acres. The majority of the site is comprised of Cashel silty clay (I293B), which is found in 0-6% slopes and occasionally flooded. The major soil component (80%) is Cashel, a loamy overflow that is non-hydric, but somewhat poorly drained. This site is adjacent to a public park, with an established disk golf course on a portion of it. The Oak Savanna strategy (blue polygon) would be utilized on this site, as that habitat type lends itself well to public recreation of green space. Walking trails with interpretive signage could be incorporated for public outreach, explaining the FMM Project and its associated mitigation measures to the general public.

Site 18 – OIN 1060:

This site is a former building site/flood buyout property, located adjacent to the Wild Rice River and measures approximately 3.1 acres. The southern half of this site falls within the 10-year flood inundation boundary, and the majority of the site is comprised of Wahpeton silty clay (I451D), which is described as being found on 1-15% slopes and occasionally flooded. The major components are listed as Wahpeton (35%), which is a moderately well drained, non-hydric clayey soil, and Cashel (25%), a somewhat poorly drained, non-hydric loamy overflow soil. Although this is a smaller property, it would provide additional riparian buffer benefits to the Wild Rice River. The sloped areas adjacent to the river would be planted using the Bank Stabilization strategy (orange polygon, approx. 0.21 acres) and transition into Floodplain Forest strategy (green polygon, approx. 2.9 acres) as the elevation rises, farther from the river, all the way up to the private home levee/berm located on the west side of this parcel.

Site 19 – OIN 5244, OIN 7245:

This is a former building site/flood buyout property, located adjacent to the Wild Rice River and measures approximately 4.4 acres. The majority of the site is comprised of Wahpeton silty clay (I451D), which is described as being found on 1-15% slopes and occasionally flooded. The major components are listed as Wahpeton (35%), which is a moderately well drained, non-hydric clayey soil, and Cashel (25%), a somewhat poorly drained, non-hydric loamy overflow soil. On the western edge of the property, there are Fargo-Hegne (I238A) silty clay soils mapped, which are typically found on 0-1% slopes. Major component is Fargo (50%), which is described as a poorly drained, hydric, clayey soil. Although this is a smaller property, it would provide additional riparian buffer benefits to the Wild Rice River. The sloped areas adjacent to the river would be planted using the Bank Stabilization strategy (orange polygon, approx. 0.5 acres) and transition into both the Floodplain Forest strategy (green polygon, approx. 2.5 acres), and the Oak Savanna strategy (blue polygon, approx. 1.4 acres) farther from the river.

Site 20 – OIN 815Y:

This site is located immediately adjacent to the Wild Rice River and measures approximately 9.6 acres. There are significant erosional issues on the northern end along the river, and the site contains an abandoned oxbow. The vast majority of the site, approximately 90% lies within the 10-year flood inundation boundary, and the entire site is comprised of Wahpeton silty clay

(I451D), which is described as being found on 1-15% slopes and occasionally flooded. The major components are listed as Wahpeton (35%), which is a moderately well drained, non-hydric clayey soil, and Cashel (25%), a somewhat poorly drained, non-hydric loamy overflow soil. Although this is a smaller property, it would provide additional riparian buffer benefits to the Wild Rice River and would allow for the erosional issues onsite to be addressed. The sloped areas adjacent to the river would be planted using the Bank Stabilization strategy (orange polygon, approx. 1.7 acres) and transition into Floodplain Forest strategy (green polygon, approx. 7.9 acres) farther from the river.

Site 22 – OIN 250:

This site is located immediately adjacent to the Red River of the North, measures approximately 8 acres, and is situated adjacent to the future Red River Structure. It contains a former building site and a large area that is currently in agricultural production. Much of the northern half of the site lies within the 10-year flood inundation boundary. This site is comprised of three primary soil types, with the majority of the site comprised of Wahpeton silty clay (I248A), which is described as being found on 0-2% slopes and occasionally flooded. The major component (70%) is listed as Wahpeton, which is a moderately well drained, non-hydric, clayey soil. Smaller portions of the site are mapped as Wahpeton silty clay (I248C), which is occasionally flooded and found on 6-9% slopes. The major component (80%) is Wahpeton, described as a clayey, moderately well drained, non-hydric soil. The northern portion of the site is comprised of Cashel silty clay (I293B), which is found in 0-6% slopes and occasionally flooded. The major soil component (80%) is Cashel, a loamy overflow that is non-hydric, but somewhat poorly drained. This is a high priority site for floodplain forest re-establishment, and after reforestation, would expand existing riparian buffer habitat in the Red River system. This site would be reforested using the Floodplain Forest strategy (green polygon) across the entire site.

Site 25 – OIN 809, 810, 811:

This site is a former building site that is located immediately adjacent to the Red River of the North and measures approximately 6.6 acres. There are significant erosional issues on the northern end along the river, and more than half of the site falls within the 10-year flood inundation boundary. The site is comprised of four primary soil types, with the majority being mapped as Wahpeton silty clay (I451D), which is described as being found on 1-15% slopes and occasionally flooded. The major components are listed as Wahpeton (35%), which is a moderately well drained, non-hydric clayey soil, and Cashel (25%), a somewhat poorly drained, non-hydric loamy overflow soil. The second most abundant soil type is Cashel silty clay (I293B), which is found in 0-6% slopes and occasionally flooded. The major soil component (80%) is Cashel, a loamy overflow that is non-hydric, but somewhat poorly drained. Third most abundant is Wahpeton silty clay (I248A), which is described as being found on 0-2% slopes and occasionally flooded. The major component (70%) is listed as Wahpeton, which is a moderately well drained, non-hydric, clayey soil. Finally, the least abundant soil type is Fargo silty clay (I235A), that is typically depressional in 0-1% slopes, with Fargo being its major component (75%). Fargo is described as a clayey, poorly drained, hydric soil. Although this is a smaller property, it would provide additional riparian buffer benefits to the Red River system and would allow for the erosional issues onsite to be addressed. The sloped areas adjacent to the river

would be planted using the Bank Stabilization strategy (orange polygon, approx. 0.3 acres) and transition into Floodplain Forest strategy (green polygon, approx. 6.3 acres) farther from the riverbanks for the remainder of the site. There is a dike between the former building site and the riverbank. The dike would be breached or removed to prevent water from ponding.

Site 32 – OIN 1990:

This site is located immediately adjacent to the Red River of the North, measures approximately 23.1 acres and has old oxbows located onsite. It contains a former building site, and a portion of western side of the property is currently in agricultural production. This site is located directly adjacent to the existing mitigation efforts at the aforementioned OHB mitigation site.

Approximately half of this site falls within the 10-year flood inundation boundary. This site is comprised of three primary soil types, with the majority of the site comprised of Wahpeton silty clay (I248A), which is described as being found on 0-2% slopes and occasionally flooded. The major component (70%) is listed as Wahpeton, which is a moderately well drained, non-hydric, clayey soil. Smaller portions of the site are mapped as Wahpeton silty clay (I451D), which is described as being found on 1-15% slopes and occasionally flooded. The major components are listed as Wahpeton (35%), which is a moderately well drained, non-hydric clayey soil, and Cashel (25%), a somewhat poorly drained, non-hydric loamy overflow soil. The north-eastern portion of the site is comprised of Cashel silty clay (I293B), which is found in 0-6% slopes and occasionally flooded. The major soil component (80%) is Cashel, a loamy overflow that is non-hydric, but somewhat poorly drained. After planting, this site would expand existing riparian buffer habitat in the Red River system. The steeper sloped areas adjacent to the river would be planted using the Bank Stabilization strategy (orange polygon, approx. 0.6 acres) and transition into Floodplain Forest (green polygon, approx. 22.5 acres) for the remainder of the site. Some invasive buckthorn was observed onsite in the June 2022 site visit notes.

Site 33 – OIN 1990:

This site is located near the Red River of the North and measures approximately 3.4 acres. It is currently in agricultural production, and a cursory review of aerial imagery shows agriculture use for at least the last 30 years. The majority of this site, approximately 80% lies within the 10-year flood inundation boundary, and the entire site is comprised entirely of Wahpeton silty clay (I248A), which is described as being found on 0-2% slopes and occasionally flooded. The major component (70%) is listed as Wahpeton, which is a moderately well drained, non-hydric, clayey soil. Although smaller in size, this is a high priority site for forest re-establishment, and after reforestation, would expand existing riparian buffer habitat in the Red River system. This site would be reforested using the Floodplain Forest strategy (green polygon) across the entire site. Invasive buckthorn was observed onsite in June 2022 and would be removed during planting.

Site 34 – OIN 1992:

This site is a former building site that is located immediately adjacent to the Red River of the North and measures approximately 3.3 acres. There are significant erosional issues on the eastern edge of the site along the river. The site is comprised of three primary soil types, with the majority being mapped as Wahpeton silty clay (I451D), which is described as being found on 1-15% slopes and occasionally flooded. The major components are listed as Wahpeton

(35%), which is a moderately well drained, non-hydric clayey soil, and Cashel (25%), a somewhat poorly drained, non-hydric loamy overflow soil. The second most abundant soil type is Cashel silty clay (I293B), which is found in 0-6% slopes and occasionally flooded. The major soil component (80%) is Cashel, a loamy overflow that is non-hydric, but somewhat poorly drained. Third most abundant is Sinai silty clay (I475B) which is described as being found on 0-6% slopes. The major component (80%) is listed as Sinai, which is a well-drained, non-hydric, clayey soil. Although this is a smaller property, it would provide additional riparian buffer benefits to the Red River system and would allow for the erosional issues onsite to be addressed. The sloped areas adjacent to the river would be planted using the Bank Stabilization strategy (orange polygon, approx. 0.5 acres) and transition into Floodplain Forest strategy (green polygon, approx. 2.8 acres) on the higher elevations, farther from the river.

Site 35 – OIN 8527:

This site also consists of former building sites that are located immediately adjacent to the Red River of the North, and it measures approximately 3.2 acres total, and there are significant erosional issues on the western edge along the river. The site is comprised of three primary soil types, with the majority being mapped as Aazdahl clay loam (I734A), which is found on 0-2% slopes. The major components are listed as Aazdahl (85%), which is a moderately well drained, non-hydric loamy soil. The second most abundant soil type is Zell silt loam (I150B), which is found in 2-6% slopes. The major soil components are Zell (55%), a non-hydric, well drained, thin loamy soil. Third most abundant is Cashel silty clay (I293B), which is found in 0-6% slopes and occasionally flooded. The major soil component (80%) is Cashel, a loamy overflow that is non-hydric, but somewhat poorly drained. Although this is a smaller property, it would provide additional riparian buffer benefits to the Red River system and would allow for the erosional issues onsite to be addressed. The sloped areas adjacent to the river would be planted using the Bank Stabilization strategy (orange polygon, approx. 0.3 acres) and transition into Floodplain Forest strategy (green polygon, approx. 2.9 acres) on the higher elevations, farther from the river.

Site 36 – OIN 1251, 1237:

This site is located immediately adjacent to the Red River of the North, measures approximately 6.4 acres and has significant erosional issues along the river. It contains a former building site, and a large portion of the property is currently in agricultural production. The majority of the site is mapped as Bearden silt loam (I467A) which is found on 0-2% slopes. The major component is listed as Bearden (70%), which is a somewhat poorly drained, non-hydric limy sub-irrigated soil. The other portion of the site, nearer to the river, is Wahpeton-Cashel silty clay (I416D), which is found on 1-15% slopes, and occasionally flooded. The major soil components are Wahpeton (40%), a moderately well drained, non-hydric clayey soil and Cashel (25%), a non-hydric loamy overflow that is somewhat poorly drained. Reforestation of this site would provide additional riparian buffer benefits to the Red River system and would allow for the erosional issues onsite to be addressed. The sloped areas adjacent to the river would be planted using the Bank Stabilization strategy (orange polygon, approx. 2.2 acres) and transition into Floodplain Forest strategy (green polygon, approx. 4.3 acres) on the higher elevations, farther from the river.

Site 38 – OIN 1893, 9420, 9422, 9462, 9670, 9671:

This larger site is an abandoned tree nursery located immediately adjacent to the Red River of the North that measures approximately 38.3 acres in size, and there are some erosional issues in multiple locations along the river. Much of the site along the river falls within the 10-year flood inundation boundary. The site is comprised of three primary soil types, with the majority being mapped as Fargo silty clay (I229A), found on 0-1% slopes, with Fargo being its major component (80%). Fargo is described as a clayey, poorly drained, hydric soil. The second most abundant soil type is Cashel silty clay (I293B), which is found in 0-6% slopes and occasionally flooded. The major soil component (80%) is Cashel, a loamy overflow that is non-hydric, but somewhat poorly drained. Third most abundant, found primarily along the riverbank is mapped as Wahpeton silty clay (I451D), which is described as being found on 1-15% slopes and occasionally flooded. The major components are listed as Wahpeton (35%), which is a moderately well drained, non-hydric clayey soil, and Cashel (25%), a somewhat poorly drained, non-hydric loamy overflow soil. This is a unique site that has some trees already in place, but with additional plantings, the site would increase riparian buffer benefits to the Red River system and would allow for the erosional issues onsite to be addressed. The sloped areas adjacent to the river would be supplemented with the Bank Stabilization strategy (orange polygon, approx. 0.8 acres) and transition into Floodplain Forest strategy (green polygon, approx. 37.5 acres) on the higher elevations, farther from the river. There is a plant species list of remaining trees on the nursery property (Appendix C), of which several species of Lilac (highlighted yellow in Appendix C) have been identified as potentially harmful due to their invasive nature and would need to be removed or girdled in place at the time of planting. Existing fencing and concrete driveway/entrance would also require removal.

Site 39 – OIN 1200

This site is located immediately adjacent to the Sheyenne River and measures approximately 0.34 acres. There are significant erosional issues on the western end along the river. The entire site lies outside of the 10-year flood inundation boundary, and the majority of the site is comprised of Fairdale silt loam (I480A), which is described as being a clayey substratum found on 0-3% slopes and rarely flooded. The major components are listed as Fairdale (78%), which is a moderately well drained, non-hydric loamy overflow, and LaDelle (10%), a moderately well drained, non-hydric loamy soil. Although this is a smaller property, it would provide additional riparian buffer benefits to the Sheyenne River and would allow for the erosional issues onsite to be addressed. The sloped areas adjacent to the river would be planted using the Bank Stabilization strategy (orange polygon, approx. 0.2 acres) and transition into Floodplain Forest strategy (green polygon, approx. 0.13 acres) farther from the river.

Site 41 – OIN 1885, 9416

This site is a former homesite/flood buyout property, located adjacent to the Red River of the North and measures approximately 8 acres. Much of the eastern side of the site falls within the 10-year flood inundation boundary, and the majority of the site is comprised of Wahpeton silty clay (I248A), which is described as being found on 0-2% slopes and occasionally flooded. The major component (70%) is listed as Wahpeton, which is a moderately well drained, non-hydric,

clayey soil. Along the river, the mapped soil is listed as Wahpeton silty clay (I451D), which is described as being found on 1-15% slopes and occasionally flooded. The major components are listed as Wahpeton (35%), which is a moderately well drained, non-hydric clayey soil, and Cashel (25%), a somewhat poorly drained, non-hydric loamy overflow soil. This property would provide additional riparian buffer benefits to the Red River system. The sloped areas adjacent to the river would be planted using the Bank Stabilization strategy (orange polygon, approx. 0.1 acres) and transition into Floodplain Forest strategy (green polygon, approx. 7.9 acres) farther from the river for the remainder of the site.

Site 42 – OIN 876, 1885, 9416, 9424, 9425, 9428, 9429, 9430, 9437:

This is a conglomerate of former building sites/flood buyout properties, located adjacent to the Red River of the North and measures approximately 22.9 acres. Approximately half of this site falls within the 10-year flood inundation boundary, and the majority of the site is comprised of Wahpeton silty clay (I451D), which is described as being found on 1-15% slopes and occasionally flooded. The major components are listed as Wahpeton (35%), which is a moderately well drained, non-hydric clayey soil, and Cashel (25%), a somewhat poorly drained, non-hydric loamy overflow soil. In the northern portion of the property, there is Cashel silty clay (I293B), which is found in 0-6% slopes and occasionally flooded. The major soil component (80%) is Cashel, a loamy overflow that is non-hydric, but somewhat poorly drained. This parcel would provide additional riparian buffer benefits to the Red River system. The entire site will be planted using the Floodplain Forest strategy (green polygon).

Site 43 – OIN 249 and 251:

This site is located adjacent to the Red River of the North and measures approximately 18.9 acres. Only a narrow portion of the site falls within the 10-year flood inundation boundary, and the majority of the site is comprised of Wahpeton silty clay (I248A), which is described as being found on 0-2% slopes and occasionally flooded. The major component (70%) is listed as Wahpeton, which is a moderately well drained, non-hydric, clayey soil. The second most abundant soil type is Wahpeton silty (I248B) which is described as being found on 2-6% slopes and occasionally flooded. The major component (80%) is listed as Wahpeton, which is a moderately well drained, non-hydric, clayey soil. The third most abundant soil type is found along the southern portion of the site and is mapped as Fluvaquents (I16F). It is described as a frequently flooded hapludolls complex, found on 0-30% slopes, very poorly drained and hydric. The entirety of this site will be planted using the Oak Savanna strategy (blue polygon).

6.3 Site Summary

As stated above, project impacts will occur in both North Dakota and Minnesota. Mitigation in each state will be proportional to the number of impacts resulting from construction. A summary of forest impacts and the required mitigation can be found in Table 1 above and show a total need of 270.8 acres in North Dakota, and 32.4 acres needed in Minnesota.

The OHB Site and Oxbow Country Club Restoration sites result in 13 and 63.1 acres of new forest, respectively in North Dakota. The tree plantings at these two sites were designed to fulfill a portion of the forested acreage needed, leaving an additional 194.7 acres in North Dakota.

The list of sites that have been chosen or are being considered for forest mitigation can be found below in Table 2. Additional properties suitable for forest planting will be evaluated as opportunities become available. Properties will be added and deleted from the list as the FMM Project construction progresses and properties are acquired.

Table 2. Summary of Forest Mitigation Sites

Site	Location	Total Acreage	State	Planting Strategy / Description / Notes
OHB	46.676445°N, -96.799998°W	13	ND	Bare-root seedlings were planted at a density of 300 individuals per acre.
Oxbow Country Club	46.670714°N, -96.798521°W	63.1	ND	Floodplain Forest bare-root seedlings were planted for 57.4 acres of the site and 5.7 acres were planted using direct seeding.
1	47.074170°N, -96.822399°W	12.9	ND	Floodplain Forest strategy for entire site. Currently in agricultural production.
5	46.930548°N, -96.965535°W	2.8	ND	Bank Stabilization strategy within approximately 40 yards of waterline (approx. 0.5 acre), transitioning to Floodplain Forest strategy for the remainder of the site (Approx. 2.2 acres). Majority of site is currently in agricultural production.
6	46.929561°N, -96.951558°W	21.3	ND	Floodplain Forest strategy for entire site. Majority of site is currently in agricultural production.
10	46.807957°N, -96.799153°W	14.8	ND	Oak Savanna strategy for entire site. Site is currently used as a disc golf course for public park. Incorporate trails and Outreach/Interpretive signage along trail to explain Project and mitigation efforts.
18	46.7759112°N, -96.804254°W	3.1	ND	Bank Stabilization strategy along slopes along the waterline where there are no trees along the bank in two locations (Approx. 0.2-acre total), transitioning to Floodplain Forest strategy for the remainder of the site (Approx. 2.9 acres). Site is a former building site / buyout, planting to occur all the way up to the neighboring private home levee on western border.
19	46.745041°N, -96.818052°W	4.4	ND	Bank Stabilization strategy along slopes within approximately 25 yards of waterline (approx. 0.5 acres), transitioning to Floodplain Forest (approx. 2.5 acres) and Oak Savanna strategy for the remainder of the site (approx. 1.4 acres).
20	46.710796°N, -96.833877°W	9.6	ND	Bank Stabilization strategy along slopes within approximately 25 yards of waterline (approx. 1.7 acres), transitioning to Floodplain Forest strategy for the remainder of the site (approx. 7.9 acres). Majority of site is currently in agricultural production.
22	46.703627°N, -96.786604°W	8.0	MN	Floodplain Forest strategy for entire site. Currently, majority of site in agricultural production, small portion is former building site.
25	46.701329°N, -96.789257°W	6.6	ND	Bank Stabilization strategy along slopes closer to waterline (approx. 0.3 acre, transitioning to Floodplain Forest strategy for the remainder of the

				site (Approx. 6.3 acres). Site is former building site located on Red River.
32	46.658115°N, -96.802156°W	23.1	ND	Bank Stabilization strategy along slopes closer to waterline on east end of parcel (Approx. 0.6 acre, transitioning to Floodplain Forest strategy for the remainder of the site (approx. 22.5 acres).
33	46.656163°N, -96.801739°W	3.4	ND	Floodplain Forest strategy for entire site. Site is currently in agricultural production.
34	46.653697°N, -96.799988°W	3.5	ND	Bank Stabilization strategy along slopes closer to waterline (Approx. 0.5 acre, transitioning to Floodplain Forest strategy for the remainder of the site (Approx. 2.8 acres). Site is former building site.
35	46.627644°N, -96.784524°W	3.2	MN	Bank Stabilization strategy along slopes closer to waterline (approx. 0.3 acre), transitioning to Floodplain Forest strategy for the remainder of the site (approx. 2.9 acres). Site is former building site.
36	46.625582°N, -96.778056°W	6.4	MN	Bank Stabilization strategy along slopes closer to waterline (Approx. 2.2 acre), transitioning to Floodplain Forest strategy for the remainder of the site (Approx. 4.3 acres). Site is former building site.
38	46.681169°N, -96.797228°W	38.3	ND	Bank Stabilization strategy along slopes closer to waterline (approx. 0.8 acres), transitioning to Floodplain Forest strategy for the remainder of the site (approx. 37.5 acres). Site is former tree nursery; several existing trees will need girdled or removed to avoid invasive spread (see site notes above in Baseline Information section).
39	46.732008°N, -96.932153°W	0.34	ND	Bank Stabilization strategy along slopes closer to waterline (approx. 0.21 acres), transitioning to Floodplain Forest strategy for the remainder of the site (approx. 0.13).
41	46.687607°N, -96.789970°W	8.0	ND	Bank Stabilization strategy along slopes closer to waterline (approx. 0.12 acres), transitioning to Floodplain Forest strategy for the remainder of the site (approx. 7.9 acres).
42	46.691986°N, -96.788151°W	22.9	ND	Floodplain Forest strategy for the entire site.
43	46.703003°N, -96.783600°W	18.9	MN	Oak Savannah strategy for the entire site.

****Acreages listed in table are subject to change based on real estate acquisition. Will be updated as needed.***

Table 3. Summary of Potential Forest Mitigation Acreage by State

	North Dakota	Minnesota
Bank Stabilization	5.4 acres	2.5 acres
Oak Savanna	16.3 acres	18.9 acres
Floodplain Forest	229.3 acres	15.2 acres
State Totals	250.9 acres	36.6 acres
Grand Total	287.5 acres	

****Acreages listed in table are subject to change based on real estate acquisition. Will be updated as needed.***

7. Monitoring & Management

Monitoring and adaptive management are the responsibility of the Non-Federal Sponsors per the Project Partnership Agreement (PPA), dated 11 July 2016 and amended 19 March 2019. After initial construction the mitigation sites will be monitored to assess the success in restoring and creating forest mitigation. Periodic mowing, burning, and spot treating with herbicide will be required to control the establishment of non-desirable species and increase the successful establishment of planted species (Appendix G). Once seeded, it is anticipated that native species will take approximately three to five years to become established under favorable growing conditions.

Other adaptive management measures may be employed to address vegetative or hydrologic concerns identified during and after the initial establishment period. Maintenance needs will be identified as part of the annual monitoring conducted to determine compliance with the mitigation performance standards for the site and as part of the periodic inspections conducted in accordance with the operation and maintenance plan for the project.

7.1 Monitoring Requirements

Monitoring shall be performed at years one, three, six, and ten after the initial planting to gage performance and provide adaptive management through planting and maintenance practices, as necessary. Monitoring will include a seedling survival check during the first full growing season after planting, an annual invasive species checks to year five in the form of a percent cover survey, and seedling surveys to determine tree density and diversity at years one, three, six, and ten (Appendix E). Seedling surveys of a 0.01-acre circular plot will consist of identifying all woody stems to species and measuring their heights (Appendix E). Plots will be placed randomly across the mitigation property with a 66 foot buffer around each point to avoid overlap. Each survey year plots will be re-randomized in order to ensure greater coverage of the sites. After year ten, tree survival and composition will be monitored every five years thereafter using the forest inventory protocol provided in Appendix E to determine basal area and trees per acre and percent canopy cover until it can be demonstrated that the value of the forest habitat lost has been replaced through mitigation (see Attachment 6 of the EIS for an example of habitat quantification). The monitoring results will be compiled, interpreted, and described in monitoring reports that will be shared with the FMM Forest Resource Group to provide management recommendations using the process defined in the AMMP. The Non-Federal Sponsors would be responsible for providing this justification and receiving approval from the Adaptive Management Team (AMT).

7.2 Monitoring Reports

Monitoring reports shall be concise and effectively provide the information necessary to assess the status of the forest mitigation projects. Monitoring shall commence the first full growing season following completion of construction (construction includes earth moving, excavation and other physical work as well as planting and seeding). The first monitoring report shall be submitted on or before December 31st of the first monitoring year. This report shall include

information about invasive species, seedling survival following planting, seedling density, and diversity of herbaceous and woody species. Subsequent mandatory reports shall include the same information except for seedling survival information and be submitted on or before December 31st for years two, three, six, and ten (total of five reports). Additional reports will be required every five years until the functional value of the forest mitigation can demonstrate that it has replaced that of the forest impacted by the FMM Project.

Monitoring reports shall contain the following information and any additional information necessary to evaluate the performance of the reforestation site:

1. Name of party responsible for conducting the monitoring and the date(s) the inspection was conducted.
2. A brief paragraph describing the mitigation acreage and type of resources authorized to compensate for the impacts.
3. Written description of the location of the compensatory mitigation project including information to locate the site perimeter(s), and coordinates of the mitigation site (expressed as latitude, longitude, UTM, state plane coordinate system, etc.)
4. Dates the compensatory mitigation project commenced and/or was completed.
5. Short statement on whether the performance standards are being met.
6. Summary data, including percent cover of invasive species, species diversity of herbaceous and woody species, and seedling densities.
7. Mandatory set points for photos to provide visual documentation of changes and growth over time.
8. Maps showing the location of the reforestation site relative to other landscape features, habitat types, locations of photographic reference points, transects, sampling data points, and/or other features pertinent to the mitigation plan.
9. A summary of the amounts and type of habitat restored, enhanced, and created at the site.
10. Dates of any recent corrective or maintenance activities conducted since the previous report submission.
11. Specific recommendations for any additional corrective or remedial actions.

7.3 Performance Standards

The results of monitoring will be compared to the performance standards to evaluate the effectiveness of the mitigation and determine if additional planting or maintenance measures are necessary.

Performance standards are survivorship and functionally based, whereas each forest strategy must develop into a representative community that is sufficient in density and diversity to provide the intended habitat function.

7.3.1 Bank Stabilization

Bank stabilization sites must meet 80% survivorship of woody vegetation at the end of the monitoring period and provide adequate ground coverage to hold stream banks from further

erosion during high water events. By year three, ground coverage should meet or exceed 80% with new plantings and volunteer woody vegetation growth. If more than 20% open ground is observed, an interventional stake planting may be needed.

Herbaceous native vegetation will be planted to provide initial stabilization while the woody vegetation establishes. Long-term maintenance or monitoring of herbaceous vegetation is not required for bank stabilization. Invasive species will be maintained as described in Section 7.3.4.

7.3.2 Floodplain Forest

Floodplain forest sites must provide increasingly higher quality riparian buffer and corridor habitat as natural succession of these sites occurs over time. To achieve this, sites must have high enough survivorship of planted seedlings following year one to meet the minimum number of stems required for full stocking (Appendix F). If survivorship of seedlings is not great enough to meet this standard, then a combination of natural regeneration and planted seedlings shall be used to meet the minimum number of stems required. If minimum stocking requirements cannot be met through a combination of planted and naturally regenerated seedlings, then supplemental planting shall occur to meet the stocking requirements.

Herbaceous native vegetation will be planted to prevent invasive or noxious weeds from establishing between tree plantings. Long-term maintenance and monitoring of herbaceous vegetation is not required for the floodplain forest. Invasive species will be maintained as described in Section 7.3.4.

7.3.3 Oak Savannah

Oak Savannah sites must meet the target of bur oak survivability that will provide 10-50% total canopy cover at maturity. To meet this target, stocking standards shall be met in the interim to increase the likelihood that there will be adequate canopy cover in the future (Appendix F). If stocking goes below the desired trees per acre then supplemental planting with bare root stock shall be considered in order to meet the desired canopy cover at maturity.

Grassland areas within the Oak Savannah will be measured with interim and final vegetation standards as shown in Table 4 below. Interim vegetation standards are intended to keep vegetation establishment on track to meet the final vegetation standards. The interim vegetation standards shall be met no later than year 3 for Interim Standard 1 and year 4 for Interim Standard 2. Invasive species will be maintained as described in Section 7.3.4.

Table 4. Oak Savannah grassland vegetation performance standards.

VEGETATION PERFORMANCE STANDARDS			
Performance Standard	Interim 1	Interim 2	Final
Relative Areal Cover	≥50% NNI; <50% InNN ¹	≥70% NNI; <30% InNN ²	≥80% NNI; <20% InNN

Perennial Species Composition of NNI	8 ^{≥1}	12 ^{≥1}	15 ^{≥1}
Maximum Allowance for Unvegetated Areas	≤5%/acre ¹	≤2%/acre ²	≤2%/acre
¹ For ≥1 consecutive growing seasons ² For ≥2 growing season after Interim 1 is met NNI = native, non-invasive InNN = invasive, non-native			

7.3.4 Invasive Species

Any mitigation areas one-quarter acre in size or larger that have greater than 50 percent areal cover of invasive, non-native (InNN) species must be treated (e.g., herbicide) and/or cleared (e.g., disked) and then planted with native seed, live stakes, or seedlings, appropriate to the planting strategy.

7.4 Long-term Management Plan

As part of the Federal FMM Project the forest mitigation sites will be turned over to the non-federal sponsors (the Metro Flood Diversion Authority, Fargo, ND, and Moorhead, MN) once construction of the project is completed. The non-federal sponsors would then assume responsibility for maintenance and management of the mitigation sites in accordance with the Project Partnership Agreement.

7.5 Adaptive Management Plan

An adaptive management plan for compensatory mitigation sites was initially prepared by the U.S. Army Corps of Engineers, St. Paul District as part of the Final Feasibility Report and Environmental Impact Statement for the Fargo-Moorhead Metropolitan Area Flood Risk Management Project, dated July 2011. The AMMP was provided as Attachment 6 to that report. The AMMP is a living document, was updated in Supplemental Environmental Assessments, and will continue to undergo alterations per the process provide in the AMMP. The AMMP includes corrective actions that can be taken in the event that mitigation sites do not meet the performance standards listed previously.

7.6 Site Protection Instrument

The sites identified as potential options for forest mitigation are either planned for acquisition or are currently owned by one of the local governments that collectively make up the non-federal sponsors. A conservation easement or other protective mechanism will be established for each mitigation site. The mechanism will prohibit incompatible uses at the site including plowing, grading, mining, and other actions that would directly or indirectly reduce the quality and quantity of forest at each site.

7.7 Financial Assurance

A financial assurance is not proposed for these mitigation sites since it is part of a federal project undertaken by the U.S. Army Corps of Engineers. The Corps will ensure that the mitigation sites are constructed in accordance with the AMMP and the Forest Mitigation Plan and that the sites meet the established performance standards.

Appendix A

Seed Mixes



Woodland Edge South & West

36-211

Common Name	Scientific Name	Rate (kg/ha)	Rate (lb/ac)	% of Mix (% by wt)	Seeds/ sq ft
big bluestem	<i>Andropogon gerardii</i>	1.12	1.00	2.90%	3.68
side-oats grama	<i>Bouteloua curtipendula</i>	1.12	1.00	2.89%	2.20
kalm's brome	<i>Bromus kalmii</i>	1.68	1.50	4.34%	4.40
nodding wild rye	<i>Elymus canadensis</i>	1.40	1.25	3.61%	2.38
bottlebrush grass	<i>Elymus hystrix</i>	0.36	0.32	0.91%	0.88
slender wheatgrass	<i>Elymus trachycaulus</i>	1.40	1.25	3.64%	3.18
switchgrass	<i>Panicum virgatum</i>	0.07	0.06	0.17%	0.30
little bluestem	<i>Schizachyrium scoparium</i>	0.69	0.62	1.79%	3.40
Indian grass	<i>Sorghastrum nutans</i>	1.12	1.00	2.89%	4.40
	Total Grasses	8.97	8.00	23.14%	24.82
common yarrow	<i>Achillea millefolium</i>	0.03	0.03	0.09%	2.00
blue giant hyssop	<i>Agastache foeniculum</i>	0.11	0.10	0.28%	3.20
white snakeroot	<i>Ageratina altissima</i>	0.03	0.03	0.09%	1.70
white prairie clover	<i>Dalea candida</i>	0.19	0.17	0.50%	1.20
Canada tick trefoil	<i>Desmodium canadense</i>	0.16	0.14	0.42%	0.29
ox-eye	<i>Heliopsis helianthoides</i>	0.15	0.13	0.38%	0.30
wild bergamot	<i>Monarda fistulosa</i>	0.07	0.06	0.18%	1.60
stiff goldenrod	<i>Oligoneuron rigidum</i>	0.07	0.06	0.17%	0.90
Clayton's sweet cicely	<i>Osmorhiza claytonii</i>	0.07	0.06	0.17%	0.06
smooth wild rose	<i>Rosa blanda</i>	0.07	0.06	0.17%	0.06
black-eyed susan	<i>Rudbeckia hirta</i>	0.20	0.18	0.52%	6.10
Lance-leaved Figwort	<i>Scrophularia lanceolata</i>	0.06	0.05	0.14%	3.20
zigzag goldenrod	<i>Solidago flexicaulis</i>	0.02	0.02	0.05%	0.50
showy goldenrod	<i>Solidago speciosa</i>	0.07	0.06	0.18%	1.80
smooth aster	<i>Symphotrichum laeve</i>	0.07	0.06	0.19%	1.30
American vetch	<i>Vicia americana</i>	0.20	0.18	0.52%	0.14
golden alexanders	<i>Zizia aurea</i>	0.12	0.11	0.33%	0.46
	Total Forbs	1.68	1.50	4.38%	24.80
Oats	<i>Avena sativa</i>	28.02	25.00	72.48%	11.14
	Total Cover Crop	28.02	25.00	72.48%	11.14
	Totals:	38.67	34.50	100.00%	60.75
Purpose:	Partly shaded grassland planting for native roadsides, reclamation, etc.				
Planting Area:	Tallgrass Aspen Parklands, Prairie Parkland, and Eastern Broadleaf Forest Provinces. Mn/DOT Districts 2(west), 3B, 4, Metro, 6, 7 & 8.				

Riparian S&W 34-262

Updated: 2022

This mix has been designed for riparian areas along rivers, streams and other waterbodies in the southern and western parts of Minnesota with areas of moist soils and potential flooding during part of the growing season and full to partial sun where land is being converted from other uses such as agriculture or non-native grasses to riparian plants.



Partners also include stakeholder collaboration among Non-profits, Seed vendors, SWCD, Tribal Governments, Consultants, County and Cities. (see stakeholder list on [website](#))

Common Name	Scientific Name	Rate (lb/ac)	% of Mix (by weight)	% by Seed	Seeds/sq ft
big bluestem	<i>Andropogon gerardii</i>	2.18	6.71%	4.50%	8.00
American slough grass	<i>Beckmannia syzigachne</i>	0.65	2.01%	6.75%	12.00
bluejoint	<i>Calamagrostis canadensis</i>	0.02	0.06%	1.12%	2.00
riverbank wild rye	<i>Elymus riparius</i>	0.28	0.87%	0.17%	0.30
downy wild rye	<i>Elymus villosus</i>	0.25	0.76%	0.28%	0.50
Virginia wild rye	<i>Elymus virginicus</i>	1.30	4.00%	1.12%	2.00
tall manna grass	<i>Glyceria grandis</i>	0.12	0.36%	3.54%	3.00
fowl manna grass	<i>Glyceria striata</i>	0.08	0.23%	1.41%	2.50
rice cut grass	<i>Leersia oryzoides</i>	0.08	0.25%	0.56%	1.00
fowl bluegrass	<i>Poa palustris</i>	0.25	0.77%	6.75%	12.00
prairie cordgrass	<i>Spartina pectinata</i>	0.17	0.51%	0.22%	0.40
	Grasses Subtotal	5.38	16.53%	26.42%	43.70
porcupine sedge	<i>Carex hystericina</i>	0.09	0.28%	0.56%	1.00
pointed broom sedge	<i>Carex scoparia</i>	0.13	0.40%	2.25%	4.00
awl-fruited sedge	<i>Carex stipata</i>	0.03	0.10%	0.22%	0.40
tussock sedge	<i>Carex stricta</i>	0.01	0.02%	0.06%	0.10
fox sedge	<i>Carex vulpinoidea</i>	0.11	0.34%	2.25%	4.00
marsh spikerush	<i>Eleocharis palustris</i>	0.02	0.05%	0.17%	0.30

path rush	<i>Juncus tenuis</i>	0.02	0.07%	4.50%	8.00
dark green bulrush	<i>Scirpus atrovirens</i>	0.12	0.36%	11.24%	20.00
woolgrass	<i>Scirpus cyperinus</i>	0.05	0.15%	16.86%	30.00
	Sedges & Rushes Subtotal	0.58	1.77%	38.11%	67.80
Canada anemone	<i>Anemone canadensis</i>	0.03	0.10%	0.06%	0.10
marsh milkweed	<i>Asclepias incarnata</i>	0.26	0.79%	0.25%	0.45
nodding bur marigold	<i>Bidens cernua</i>	0.05	0.16%	0.22%	0.40
common marsh marigold	<i>Caltha palustris</i>	0.01	0.02%	0.03%	0.05
common boneset	<i>Eupatorium perfoliatum</i>	0.03	0.10%	1.12%	2.00
grass-leaved goldenrod	<i>Euthamia graminifolia</i>	0.01	0.04%	0.84%	1.50
spotted Joe pye weed	<i>Eutrochium maculatum</i>	0.09	0.27%	1.69%	3.00
autumn sneezeweed	<i>Helenium autumnale</i>	0.10	0.32%	2.81%	5.00
giant sunflower	<i>Helianthus giganteus</i>	0.03	0.08%	0.06%	0.10
Blue lobelia	<i>Lobelia siphilitica</i>	0.04	0.13%	4.50%	8.00
Winged Loosestrife	<i>Lythrum alatum</i>	0.00	0.01%	0.17%	0.30
blue monkey flower	<i>Mimulus ringens</i>	0.02	0.07%	11.24%	20.00
swamp lousewort	<i>Pedicularis lanceolata</i>	0.03	0.11%	0.28%	0.50
obedient plant	<i>Physostegia virginiana</i>	0.02	0.08%	0.06%	0.10
Virginia mountain mint	<i>Pycnanthemum virginianum</i>	0.02	0.08%	1.12%	2.00
tall coneflower	<i>Rudbeckia laciniata</i>	0.10	0.30%	0.28%	0.50
cup plant	<i>Silphium perfoliatum</i>	0.19	0.60%	0.06%	0.10
Riddell's goldenrod	<i>Solidago riddellii</i>	0.01	0.05%	0.28%	0.50
eastern panicled aster	<i>Symphyotrichum lanceolatum</i>	0.03	0.08%	0.84%	1.50
New England aster	<i>Symphyotrichum novae-angliae</i>	0.03	0.10%	0.45%	0.80
tall meadow-rue	<i>Thalictrum dasycarpum</i>	0.02	0.07%	0.03%	0.06
blue vervain	<i>Verbena hastata</i>	0.09	0.27%	1.69%	3.00
bunched ironweed	<i>Vernonia fasciculata</i>	0.06	0.17%	0.28%	0.50
Culver's root	<i>Veronicastrum virginicum</i>	0.01	0.04%	2.25%	4.00
golden alexanders	<i>Zizia aurea</i>	0.20	0.61%	0.45%	0.80
	Forbs Subtotal	1.48	4.65%	31.06%	55.26

Oats	<i>Avena sativa</i>	25.00	77.07%	6.26%	11.14
	Cover Crop Subtotal	25.00	77.07%	6.26%	11.14
	Total	32.44	100.0%	101.9%	177.90

Seed Mix Enhancements or Substitutions

List of Additional Species to Add Diversity or for Substitutions

The numbers (1-9) are species ranges that relate to the MN Ecological Subsections.

Riparian South & West

Updated 10-01-2022

Grasses:

Scientific Name	Common Name	Recommended Seeds per Square Foot
<i>Bromus pubescens</i>	Hairy Wood Chess	2
<i>Calamagrostis canadensis</i>	Bluejoint	3
<i>Calamagrostis stricta</i> (2,5,8,9)	Narrow Reedgrass	2
<i>Elymus villosus</i>	Downy Wild Rye	3
<i>Glyceria canadensis</i> (1,2,5,6)	Rattlesnake Grass	3
<i>Leersia virginica</i> (6-9)	White Grass	2
<i>Muhlenbergia racemosa</i>	Marsh Muhly Grass	2

Forbs:

Scientific Name	Common Name	Recommended Seeds per Square Foot
<i>Ageratina altissima</i> (4,6-8)	White Snakeroot	2
<i>Amorpha fruticosa</i> (3-9)	Indigo Bush	1
<i>Chelone glabra</i> (1,3,5-8)	White Turtlehead	2
<i>Cicuta maculata</i>	Spotted Water Hemlock	1
<i>Galium boreale</i>	Northern Bedstraw	2
<i>Gentiana andrewsii</i> (3-9)	Bottle Gentian	3
<i>Helianthus grosseserratus</i> (3,4,7-9)	Sawtooth Sunflower	.5
<i>Impatiens pallida</i> (5-8)	Pale Touch-Me-Not	1
<i>Lobelia cardinalis</i>	Cardinal Flower	3
<i>Lobelia spicata</i>	Rough-spiked Lobelia	3
<i>Lysimachia ciliata</i>	Fringed Loosestrife	2
<i>Mentha arvensis</i> (1-9)	Wild Mint	4
<i>Physostegia virginiana</i>	Obedient Plant	2
<i>Salix bebbiana</i> (1-9)	Bebb's Willow	1
<i>Salix discolor</i> (1-9)	Pussy Willow	1

<i>Add Salix petiolaris (1-9)</i>	Meadow Willow	1
<i>Scrophularia lanceolata (1,5-9)</i>	Lance-leaved Figwort	1
<i>Silphium perfoliatum (7,8,9)</i>	Cup Plant	1
<i>Teucrium canadense (1,4,6-9)</i>	Germander	1
<i>Veronicastrum virginicum(3-9)</i>	Culver's Root	3

Sedges:

Scientific Name	Common Name	Recommended Seeds per Square Foot
<i>Carex bebbii</i>	Bebb's Sedge	.5
<i>Carex brevoir</i>	Short Sedge	.5
<i>Carex emoryi</i>	Emory's Sedge	.5
<i>Carex haydenii</i>	Hayden's Sedge	.5
<i>Carex pellita</i>	Wooly Sedge	.5
<i>Juncus dudleyi</i>	Dudley's Rush	10
<i>Juncus effusus (1,2,5-7)</i>	Soft Rush	10

Riparian South and West 34-261 Seed Mix Guidance

Seed mix name: Riparian South and West 34-262
(Previously 34-261)

Geographic area: Southern and Western
Minnesota

Year of development:2009

Year/s of update:

Status (Standard or Pilot mix): Standard

Primary and Secondary Functions:

Primary – Wildlife habitat, restoration of wetland functions, and water management

Secondary – Carbon Sequestration, emission reductions, pollinator habitat, songbird habitat

Similar State Mixes: Riparian Northeast 34-362, Wet Meadow Northeast 34-372, Wet Meadow South and West 34-272

Compatible NRCS Practice Standards: NA

Compatible Minnesota CRP Practices: NA

Suitable Site Conditions: Riparian areas along rivers, streams and other waterbodies in the southern and western parts of Minnesota with areas of moist soils and potential flooding during part of the growing season and full to partial sun where land is being converted from other uses such as agriculture or non-native grasses to riparian plants.

How to Modify for Site Conditions and Goals: This mix includes a list of additional species that can be considered to add species diversity. Site conditions such as sunlight, soils, hydrology and existing vegetation along with functional goals for the project such as carbon sequestration, pollinator habitat,



and benefit to bird species can all have an influence on species selection and the modification of seed mixes. Additional plant species can also be added from containerized plants. It is also common that seed substitutions ([see list](#)) are used for wetland seed mixes when other species are not available.

Site Preparation: Primary goals for site preparation tend to focus on controlling weed species and providing ideal growing conditions for seed or plants to be installed. Site preparation methods vary depending on past uses of the site and the weed species that are present. The protection of microorganism populations and native seedbanks, preventing soil erosion, and managing weed establishment are all considerations during the site preparation process. In most cases, non-herbicide methods are preferred over herbicide intensive methods to protect aquatic organisms and soil microfauna, but herbicides may be the most efficient method of controlling some invasive perennial species. It is common for many conservation plantings to transition from corn or soybean production. Fields that are in agriculture often have control of most weeds. Another consideration is that several chemicals being used for weed control, along with herbicides (for herbicide-resistant crops) act as pre-emergents or post-emergents (designed to inhibit germination) and can be a problem for native vegetation establishment from seed. Investigate prior chemical use and labels to help define probability of having chemical carryover that could/should be addressed by using temporary cover crops to allow time for chemicals to break down. If a site is in perennial weeds such as smooth brome, quack grass or bluegrass and cannot be put into agricultural production for one or two seasons intensive site preparation may be needed. Herbicide application is often recommended, as tilling alone may re-suspend the rhizomes, allowing them to continue growing. For species such as reed canary grass and giant reed grass, cropping with chemicals that break down quickly, or combinations of mowing, herbicide application, prescribed burning, and tilling (or possibly additional herbicide application) may be needed. The [Minnesota Wetland Restoration Guide](#) provides detailed management recommendations for a wide range of species.

Seeding Dates:

Wetland seed mixes are most often installed in the fall after October 15th as a dormant seeding as most sedges, rushes and forbs need a winter to break their seed dormancy and start growing. It is also common to wait until shortly before snowfall to prevent the loss of seed from wind, birds and rodents. Snow seeding is conducted during early or late winter when there is less than four inches of snow, and on sunny days when seed can move to the soil surface. This technique has been successful for a wide variety of species types. Refer to the Minnesota Wetland Restoration Guide for more information about snow seeding. Riparian seed can also be installed in the spring once soil temperatures reach 50 degrees Fahrenheit until June 30th but only a portion of the seed mix will germinate that first year. If a project will be constructed in the spring/early summer or will have flowing or fluctuating water levels it may be better to seed later in the spring after water levels stabilize.

Seedbed preparation

Methods that are used to prepare a seedbed can vary depending on the type of seeding equipment to be used. If a traditional native seed drill will be used, a smooth, firm seedbed is required. Soybean fields generally are sufficiently prepared for a native seed drill, but sites that were recently tilled will require additional soil treatment such as harrowing and rolling to prepare an adequate seedbed and prevent seed from being buried too deep. Broadcast seeding can be conducted on soybean or corn fields, or fields that have been disked, as long as the soil is allowed to settle before seeding. Some practitioners have found that broadcast seeding on a smooth surface (not tilled or disked) leads to the establishment of higher diversity. It is important that the soil surface is not too hard packed, so cultipacking or light harrowing of crop fields before broadcast seeding may be needed. Seed can be lost on smooth surfaces, so it is recommended to seed into temporary cover crops or to roll sites after seeding.

Temporary Cover Crops and Mulch

The use of short-lived temporary cover crops help stabilize project sites and minimize the need for additional mulch in preparation of planting native seed mixes. They can also provide time to observe weed problems, and to allow for proper weed control before fall seeding. Temporary cover crops such as oats or winter wheat (the two species most commonly used) should be mowed to 10-12 inches before seeds mature (or harvested upon maturity) to prevent re-seeding. Slough grass (*Beckmannia syzigachne*) is a common cover crop for wet areas. Annual rye grass was commonly used but is generally avoided now due to its ability to inhibit germination of native species. Other cover crops typically used in agricultural fields, such as buckwheat, pennycress, and radishes, can help stabilize soil, build soil quality, or provide weed competition as part of restoration projects. Also see [NRCS Agronomy Technical Note 31](#).

Seeding Methods

A variety of seeding equipment is used for riparian areas including broadcast seeders, traditional native seed drills, no-till drills, Brillion seeders and Trillion seeders. Broadcast seeders are most often used for seeding areas of moist soils as most of the seed is very small and needs to be near the soil surface to germinate. Brillion type seeders can also work well as they drop seed on the surface and then use a roller to ensure seed to soil contact. Specialized native seed drills can handle a wide variety of seed (fluffy, smooth, large and small) and low seeding rates so they are also an option for wetland seeding if they are calibrated correctly.

Management Methods–

Establishment Mowing

Establishment mowing may be beneficial for wet meadow plantings if the site conditions are not too wet for the equipment. Pressure from annual and biennial weeds is generally less with increased soil saturation and water depth. For smaller projects, brush cutters, string trimmers, or hand equipment can be used to target weeds and work around native plants. See the Minnesota Wetland Restoration Guide appendix: <http://bwsr.state.mn.us/restoration/resources/documents/appendix-6a-3mowing.pdf> Mowing at least twice the first season and once the second season with a flail mower or stalk chopper (to prevent smothering plants) is often helpful to decrease competition and to provide sufficient sunlight for seedlings. Weeds should be mowed to between five and eight inches before seed is allowed to set (usually as weeds reach 12-14 inches). Mowing height should be raised as native plants establish. The timing and frequency of mowing should be planned to allow sufficient light to reach native plant seedlings and preventing weed seed production. Sites with low weed competition due to sandy soils or other factors may not need mowing.

Prescribed Burning

Prescribed burning can be beneficial for some wet meadow plantings, particularly if burning was part of the historic plant community for the project. Burning can remove thatch, control invading woody and invasive plants, stimulate seed germination and new plant growth, and increase diversity in plantings. In some cases, the disturbance and increased nutrients from a burn can stimulate reed canary grass germination, so this should be considered when the species is a risk for a project. Burning is typically initiated after the third or fourth years of establishment, after native vegetation is reaching maturity. Burning is commonly conducted every three to five years. Fall and spring burns should be alternated periodically to simulate natural variation. Burn plans are needed to define the details of how the burn will be conducted, who will be involved and for contingency planning. In many cases, permits are also required. It is recommended to only burn one-half or less of a project site at a time if they are large (over 50 acres), or don't have any adjacent refuge such as other conservation lands adjacent to the site for wildlife species. Partial burns and burns that are patchy may also benefit pollinator populations if timed correctly (when pollinators are not actively foraging or pollinators have pupated and are mobile).

Spot Treatment of Weeds

Problematic perennial weeds that cannot be managed effectively with other methods may require spot treatment with herbicide for sufficient control. Examples include reed canarygrass, quackgrass, purple loosestrife, Canada thistle, and Kentucky bluegrass. In some cases, herbicide treatment is not conducted during the first or second year of establishment to avoid impact to seedlings, but it may be important to control some weeds before they have a chance to spread. A common practice for Canada thistle control involves clipping seedheads while they are in the bud stage (usually early June) and conducting herbicide application with a broad-leaf specific herbicide in the fall (mid to late October). This timing limits the application of herbicide while pollinators are active. Grass-specific herbicides are used to control reed canarygrass in wet meadow restorations, particularly on sites dominated by forbs and sedges that will not be affected. Grass-specific herbicides are most effective on young reed canary plants (6-12 inches tall) than on mature plants. There is some evidence that using surfactants along with herbicides and disking prior to application may improve effectiveness. It should be noted that grass specific herbicides are not aquatically certified and should not be used near open water. When using a broad-spectrum herbicide it is important that an aquatic safe form of glyphosate and surfactant be used near open water. When using herbicides, labels must be followed, certified applicators must conduct the treatment and Personal Protective Equipment (PPE) must be used according to label instructions. Minimize herbicide first year/spot spray year 2. Unless significant problem weeds show up.

What to Expect in Year 1: During year one of growth many native grasses, sedges, rushes and flowers will remain about one to three inches tall. Agricultural weeds such as ragweed, barnyard grass and foxtail barley may be common but not necessarily a cause for alarm. The mowing will play an important role to keep weeds managed so the native plant seedlings receive sufficient water and sunlight. The planting may have a somewhat weedy appearance this first year.

(IMAGE)

What to Expect in Year 2: During year two the native grasses and flowers may reach their mature height and some of them may flower. Mowing will still play a key role in managing weeds and allowing seedlings to grow.

(IMAGE)

What to Expect in Year 3 and Beyond: By the end of year three most of the native plants will be nearing maturity and should flower. There may be some species that are slow to establish and may not show up for several years.

Problem Solving

Poor Establishment After Year 1 – It is often difficult to determine if a seeding is successful during the first year as establishment may vary depending on weather conditions and some species may be slow to establish. It is typically best to wait until the second year to conduct any corrective actions.

Poor Establishment After Year 2 – If native plant seedlings are not establishing about every one to two feet it may be necessary to inter-seed some species into the planting.

High Annual and Biennial Weed Competition – Typically, annual and biennial weed competition is not a big problem in wet meadow plantings as they are short lived and as long as mowing is conducted before seed is set they should not add additional seed into the planting.

High Perennial Weed Competition – Dense establishment of perennial species can be a problem as it can prevent the establishment of forbs. Herbicide application may be needed to manage perennial weeds.

Low Forb Diversity After Year 3 – If grasses and sedges are establishing successfully but there is a lack of forbs it is recommended to conduct inter-seeding of additional forbs in late fall. See the [Xerces Society guide](#) for additional information about inter-seeding wildflowers.

Appendix B

MGWC 2.4: LIVE STAKES

Rigid engineering technique for bank stabilization

DESCRIPTION

The work should consist of inserting live, woody, rootable plant cuttings into streambanks and encouraging their growth. When properly utilized, the binding root mass of the mature shrubs and/or trees will ultimately stabilize and reinforce the soil.

EFFECTIVE USES & LIMITATIONS

Live staking is an economical method when local supplies of woody cuttings are readily available since the implementation of this measure requires minimal labor. When utilized effectively, live stakes can:

- act to trap soil particles in sediment laden water resulting from the erosion of adjacent land;
- slow water velocities, trap sediment, and control erosion when organized in clustered arrays along the sides of gullies;
- repair small earth slips and slumps which are frequently wet;
- help control shallow mass movement when placed in rows across slopes; and
- promote bank stabilization, especially when used in conjunction with one of the following Rosgen stream types: B3, B4, B5, B6, C1, C2, C3, C4, C5, C6, DA, E3, E4, E5, and E6.

Live staking is a *preventative* measure and should be employed before severe erosion problems occur. Additionally, in order to be effective, live stakes should be:

- planted only on streams with low to moderate flow fluctuations,
- established in the original bank soil on moderate slopes of 4:1(h:v) or less,
- planted where appropriate lighting exists, and
- used jointly with other restoration techniques especially on slopes with high erosion rates and incidents of mass wasting

MATERIAL SPECIFICATIONS

When choosing and preparing woody material for live stakes, the following guidelines should be followed:

- Live stakes should be cut from fresh, green, healthy, dormant parent plants which are adapted to the site conditions whenever possible. Commonly used woody plants for this measure include willow, poplar, and alder since they are versatile and have high growth rates with shrubby habits, fibrous root systems, and high transpiration rates, especially when in leaf. A partial listing of woody plants recommended by the United States Department of Agriculture's Soil Conservation Service is presented in [Table 2.4](#).
- Live stakes should have a diameter between 0.75 and 1.5 inches (2 to 4 centimeters) and should be long enough to reach below the groundwater table so that a strong root system can quickly develop. At least 1 foot (0.3 meters) should be exposed to sunlight. Live woody posts with diameters up to 10 inches (0.25 meters) and lengths ranging from 4 to 6 feet (1.2 to 1.8 meters) may also be used at the discretion of the project manager.
- Live stakes should be kept covered and moist at all times and should be placed in cold storage if more than a few hours elapse between the cutting and replanting times

MGWC 2.4: LIVE STAKES

Approximate Cost (\$1999): \$1 to \$4 per stake
--

INSTALLATION GUIDELINES

Live stake installation should proceed as follows (refer to [Detail 2.4](#)):

1. Live stake rooting areas should be soaked in barrels of water for 24 to 48 hours just prior to installation.
2. While keeping the bark of the live stakes intact, the side branches should be cleanly removed, the basal ends angled for easy insertion, and the tops cut square.
3. The cuttings should be implanted with the angled basal end down and buds oriented up at a minimum angle of 10 degrees to the horizontal so that rooting will not be restricted. All stakes should be positioned above the normal baseflow level. Project planners may need to study an aptly chosen vegetated reference reach for further guidance when installing live stakes.
 - In soft soils, the stakes can be inserted perpendicularly into the slope using a dead blow hammer; in hard soils, however, a steel rod should be employed to create a pilot hole before the stakes are planted.
 - Twenty percent of the live stake, and a minimum of two lateral buds, should be exposed above the slope so that green, leafy shoots will readily grow.
 - Split or otherwise damaged stakes should be discarded.
4. After the stakes have been inserted into the ground, soil should be tamped firmly around their bases to encourage root growth.
5. Successive stakes should be arranged in a triangular configuration and spaced a distance of 2 to 3 feet (0.6 to 0.9 meters) apart, allowing for a typical density of 2 to 4 cuttings per square yard (0.8 square meters). Willow posts require additional room for growth and propagation and should be planted at 3 to 5-foot (1 to 1.5-meter) intervals. When inserted in arrays, the stakes should be spaced 12 to 18 inches (30 to 46 centimeters) apart to form chevron-like rows that point downstream.
6. Unstable slope toes should be reinforced against scouring and undercutting using live fascines or rock fill to give the live stakes the best opportunity to root and grow.

Maryland's Guidelines To Waterway Construction

DETAIL 2.4: LIVE STAKES

Adapted From USDA-SCS (1994)

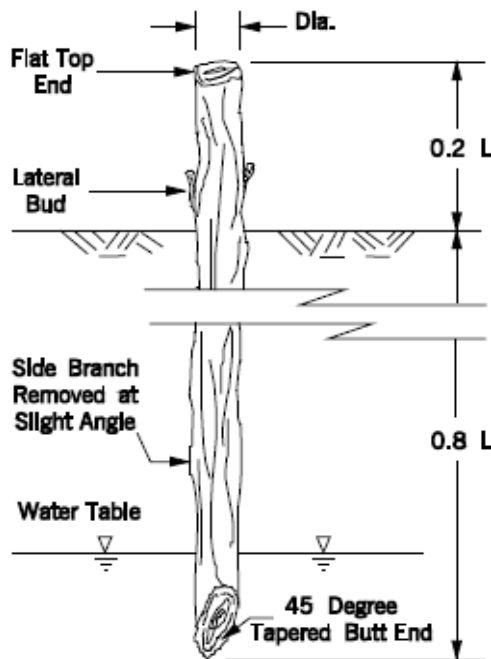

DETAIL

Live stout stakes should be long enough to reach below the groundwater table. (Generally, a length of 2 to 3 feet, or 0.6 to 0.9 meters, is sufficient.) Additionally, the stakes should have a diameter in the range of 0.75 to 1.5 inches (2 to 4 centimeters).

SECTION VIEW

Live stout stakes shall be spaced 2 to 3 feet (0.6 to 0.9 meters) apart to give a density of 2 to 4 cuttings per square yard (0.8 square meters).

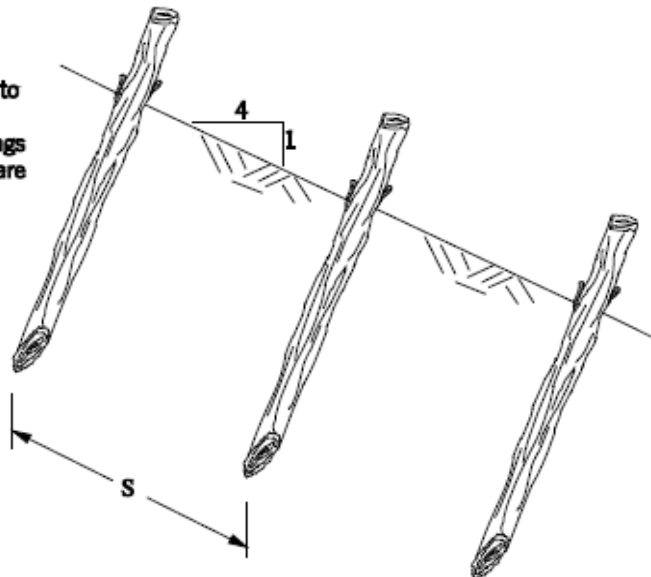

Appendix C

JDC Tree Farm Inc
Tree Nursery Inventory

Tree Description	End Count
Alder	1
American Linden	2
Amur Chokecherry	1
Austrian Pine	27
Autumn Blaze Maple	26
Autumn Brilliance Serviceberry	12
Black Hills Spruce	165
Boulevard Linden	26
Bur Oak	8
Cathedral Elm	28
Colorado Blue Spruce	75
Dolgo Crab Apple	14
Dolgo Crab Apple Top Worked	3
Dwarf Korean Lilac	11
Fat Albert Spruce	68
Flame Amur Maple Clump	28
Frontyard Linden	35
Greenspire Linden	43
Hackberry	24
Harvest Gold Linden	12
Hot Wings Tatarian Maple	12
Hotwings Tatarian Maple	9
Imperial Honey Locust	11
Japanese Tree Lilac	7
Japanese Tree Lilac Clump	20
Japanese Tree Lilac Single	3
Kentucky Coffee Tree	3
Larch	1
Littleleaf Linden	2
Matador Maple	1
Norlin Linden	4
Northern Blaze Ash	19
Northern Pin Oak	1
Northern Red Oak	3
Northfire Red Maple	1
Norway Spruce	61
Ohio Buckeye	3
Paper Birch Clump	2
Paper Birch Single Stem	1
Patmore Ash	109
Pioneer Elm	6
Ponderosa Pine	38
Prairie Cascade Weeping Willow	10
Prairie Radiance Winterberry	1

P:\Paul Bunyan Tree Service\Inventory\Spade Division Inventory\PNB Tree In
Tree Inventory Summary 03-09-21

JDC Tree Farm Inc
Tree Nursery Inventory

Tree Description	End Count
Prairie Reflection Laurel Leaf Willow	34
Prairie Spire Ash	6
Prairiefire Crab Apple	3
Quaking Aspen	13
Red Barron Crab Apple	14
Red Splendor Crab Apple	42
Redmond Linden	35
Royalty Crab Apple	5
Scotch Pine	2
Shamrock Linden	1
Showy Mountain Ash	11
Sienna Glen Clump	1
Sienna Glen Maple	29
Skyline Honey Locust	20
Spring Snow Crab Apple	36
Swamp White Oak	13
Thornless Cockspur Hawthorne	8
Thunderchild Crab Apple	43
Triumph Elm	8
St. Croix Elm	1
Marilee Crabapple	2
Grand Total	1,264

P:\Paul Bunyan Tree Service\Inventory\Spade Division Inventory\PNB Tree In
Tree Inventory Summary 03-09-21

Appendix D

FMM Forest Mitigation Mapbook



St. Paul District
GIS CENTER

US Army Corps
of Engineers®

FMM FOREST MITIGATION APPENDIX - SITE 1

Areas identified for forest mitigation
opportunities

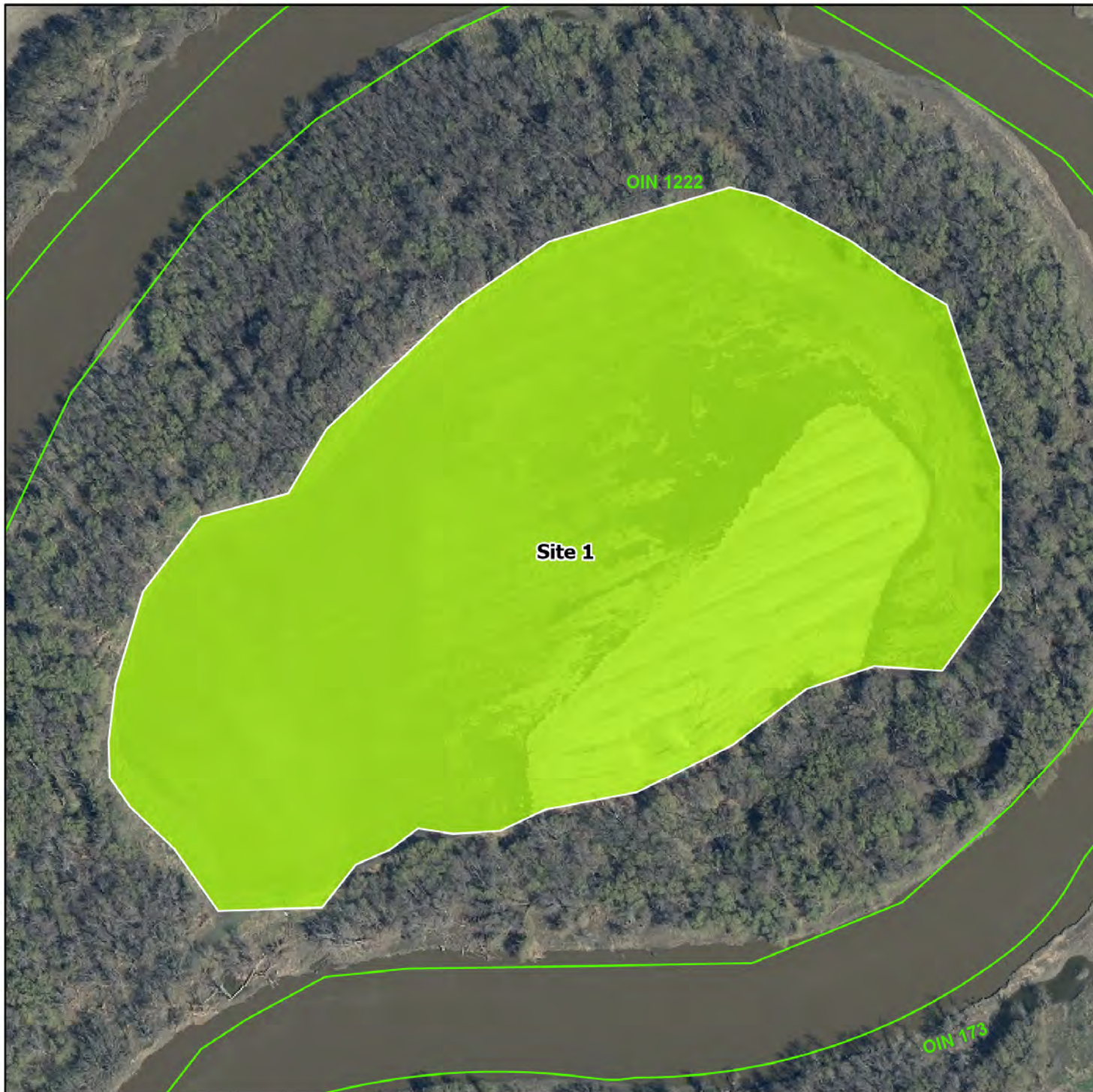
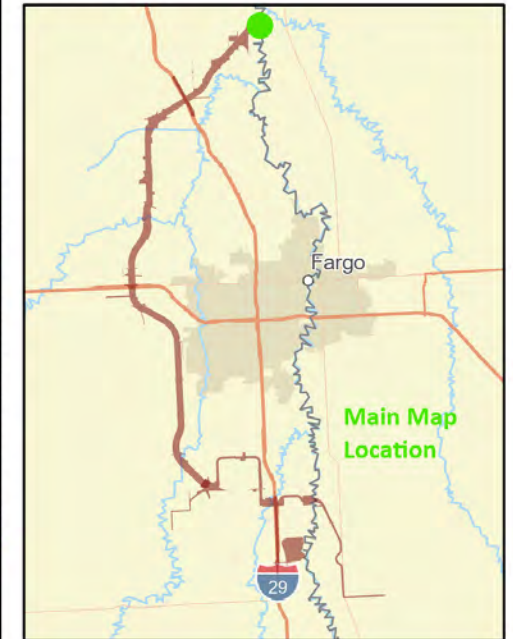

- Parcel Boundaries
- Diversion / Embankment Alignment
- Floodplain Forest

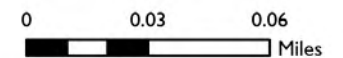

Base Image: City of Fargo Imagery (2020)



St. Paul District
GIS CENTER

US Army Corps
of Engineers®

FMM FOREST MITIGATION APPENDIX - SITE 5

Areas identified for forest mitigation
opportunities



- Parcel Boundaries
- Diversion / Embankment Alignment
- Floodplain Forest
- Bank Stabilization
- Oak Savanna

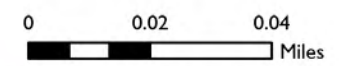

Base Image: City of Fargo Imagery (2020)



St. Paul District
GIS CENTER

US Army Corps
of Engineers®

FMM FOREST MITIGATION APPENDIX - SITE 6

Areas identified for forest mitigation
opportunities

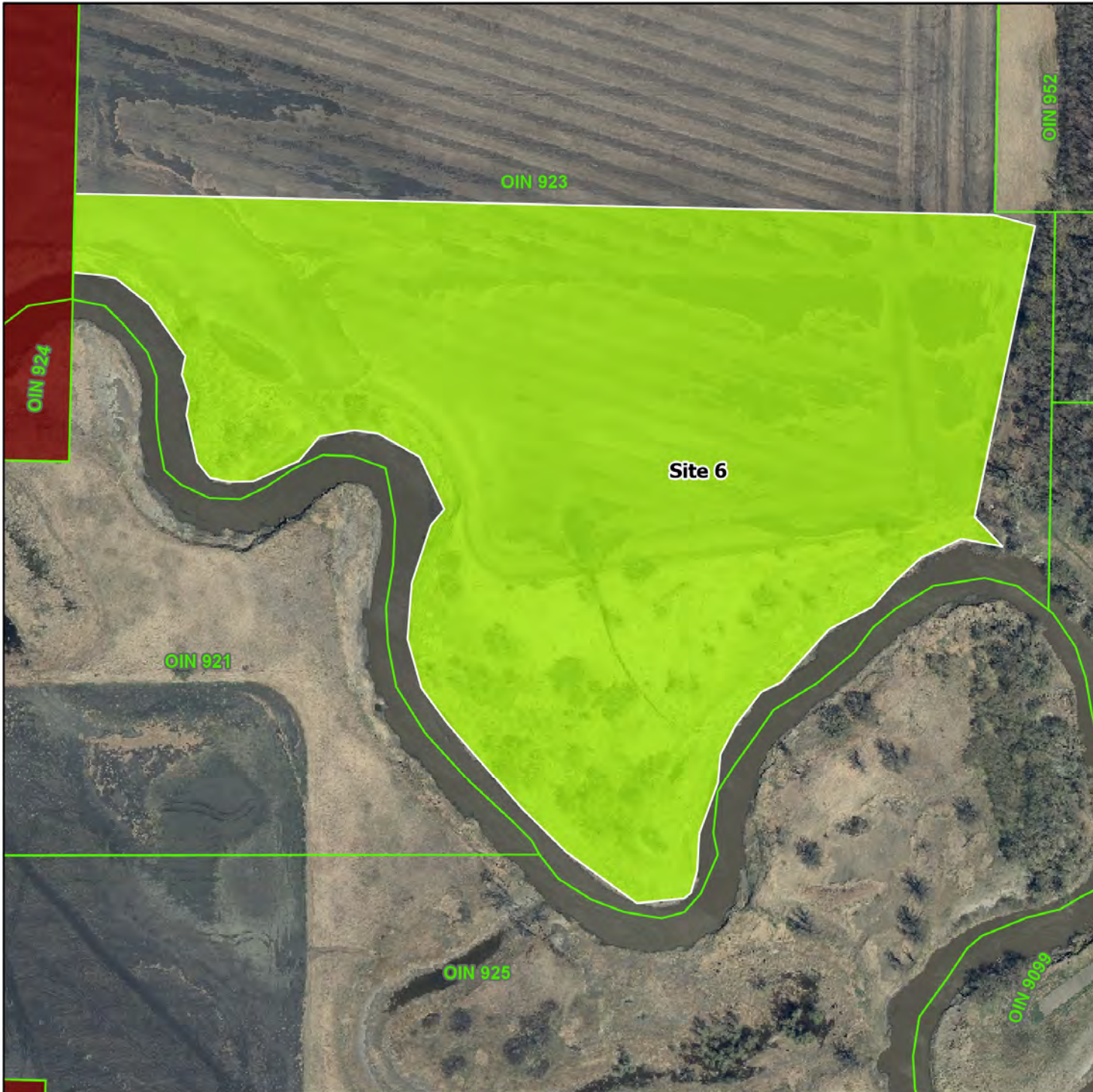
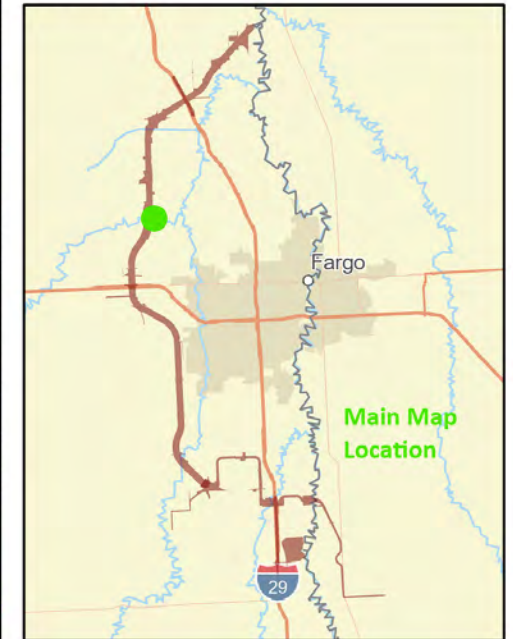

- Parcel Boundaries
- Diversion / Embankment Alignment
- Floodplain Forest

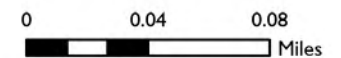

Base Image: City of Fargo Imagery (2020)





St. Paul District
GIS CENTER

US Army Corps
of Engineers®

FMM FOREST MITIGATION APPENDIX - SITE 10

Areas identified for forest mitigation
opportunities



-  Diversion / Embankment Alignment
-  Oak Savanna



0 0.04 0.08
Miles

Base Image: City of Fargo Imagery (2020)



St. Paul District
GIS CENTER

US Army Corps
of Engineers®

FMM FOREST MITIGATION APPENDIX - SITE 18

Areas identified for forest mitigation
opportunities

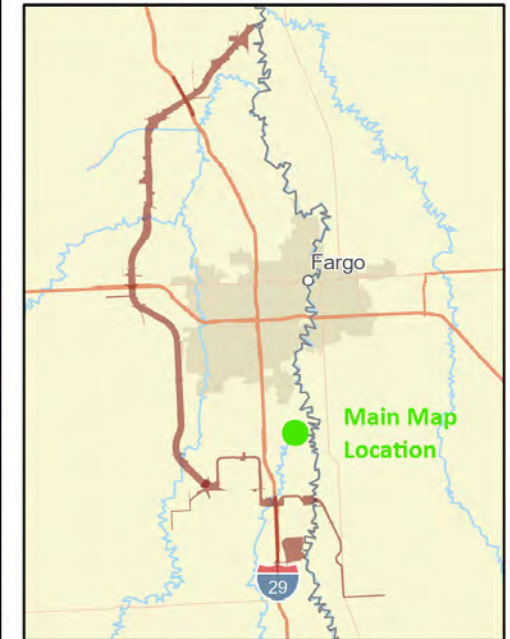

-  Parcel Boundaries
-  Diversion / Embankment Alignment
-  Floodplain Forest
-  Bank Stabilization

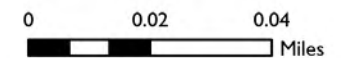

Base Image: City of Fargo Imagery (2020)



St. Paul District
GIS CENTER

US Army Corps
of Engineers®

FMM FOREST MITIGATION APPENDIX - SITE 19

Areas identified for forest mitigation opportunities

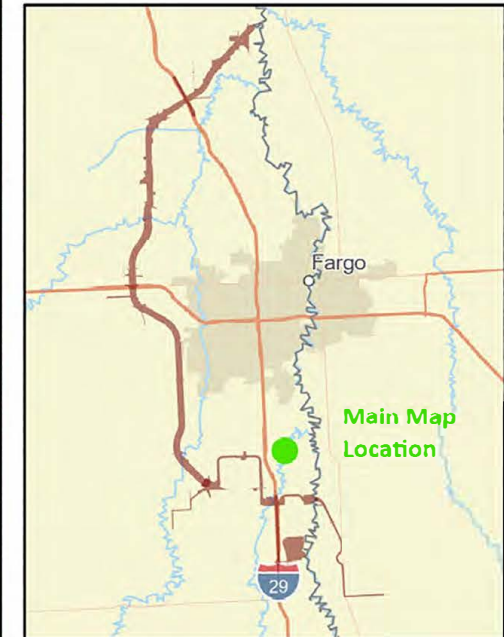

- Parcel Boundaries
- Diversion / Embankment Alignment
- Floodplain Forest
- Bank Stabilization
- Oak Savanna

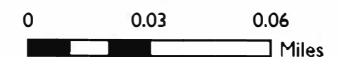

Base Image: City of Fargo Imagery (2020)



St. Paul District
GIS CENTER

US Army Corps
of Engineers®

FMM FOREST MITIGATION APPENDIX - SITE 20

Areas identified for forest mitigation
opportunities

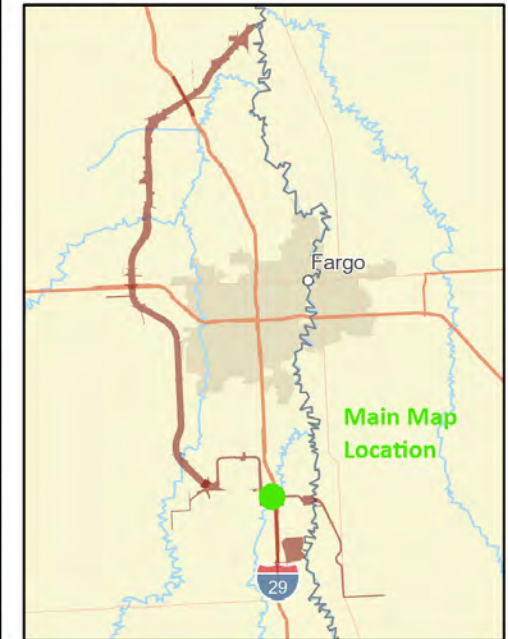

-  Parcel Boundaries
-  Diversion / Embankment Alignment
-  Floodplain Forest
-  Bank Stabilization

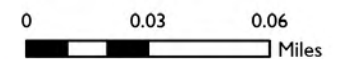

Base Image: City of Fargo Imagery (2020)



St. Paul District
GIS CENTER

US Army Corps
of Engineers®

FMM FOREST MITIGATION APPENDIX - SITE 22

Areas identified for forest mitigation
opportunities

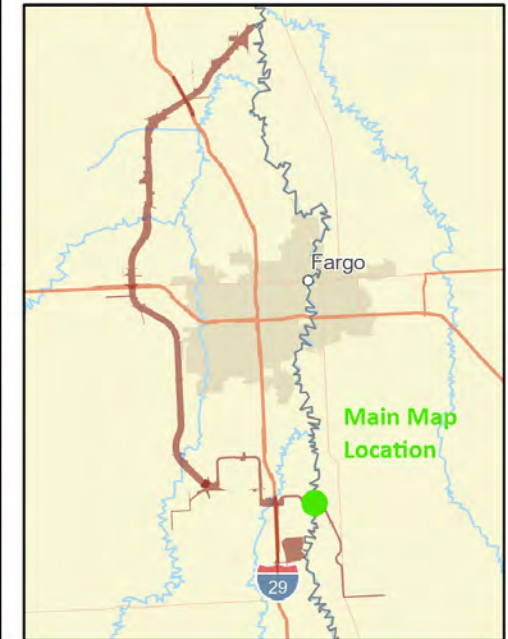

- Parcel Boundaries
- Diversion / Embankment Alignment
- Floodplain Forest
- Oak Savanna

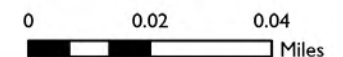

Base Image: City of Fargo Imagery (2020)







St. Paul District
GIS CENTER

US Army Corps
of Engineers®

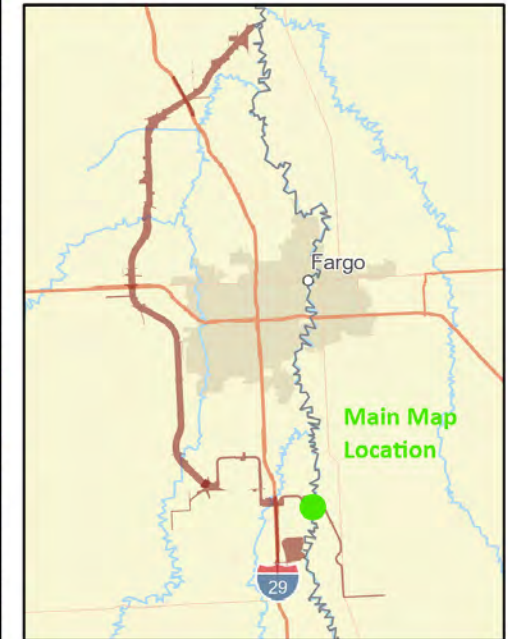
FMM FOREST MITIGATION APPENDIX - SITE 25

Areas identified for forest mitigation opportunities



-  Parcel Boundaries
-  Diversion / Embankment Alignment
-  Floodplain Forest
-  Bank Stabilization

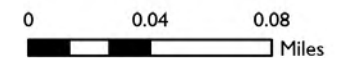

Base Image: City of Fargo Imagery (2020)







St. Paul District
GIS CENTER

US Army Corps
of Engineers®

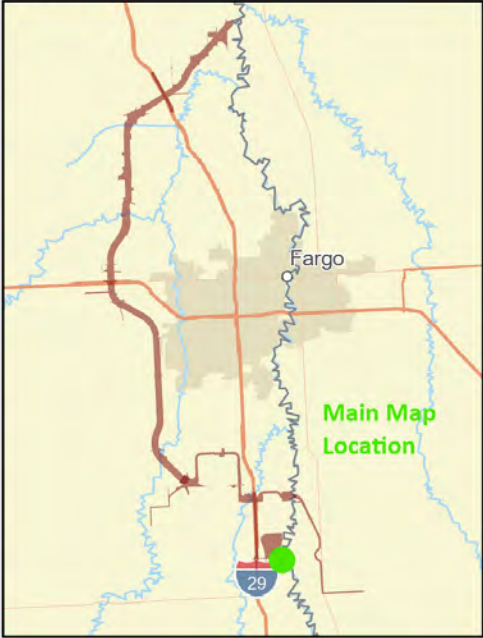
FMM FOREST MITIGATION APPENDIX - SITE 32

Areas identified for forest mitigation opportunities



-  Parcel Boundaries
-  Diversion / Embankment Alignment
-  Floodplain Forest
-  Bank Stabilization

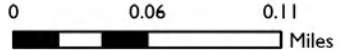

Base Image: City of Fargo Imagery (2020)

Created by: bdpdtk9 4/13/2023 4:49 PM
P:\ISA\SA_FT01_Environmental_402798\FMM Mitigation_Environmental\Forest\GIS_Support\APRX\FM14_Forest_Mitigation_Mapbook_20230328.aprx







St. Paul District
GIS CENTER

US Army Corps
of Engineers®

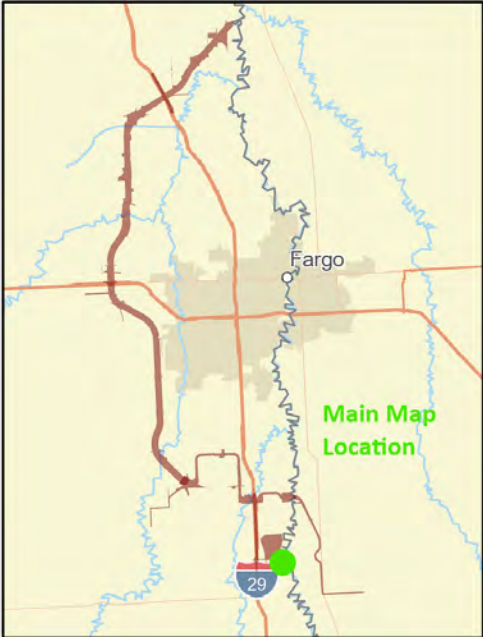
FMM FOREST MITIGATION APPENDIX - SITE 33

Areas identified for forest mitigation opportunities



-  Parcel Boundaries
-  Diversion / Embankment Alignment
-  Floodplain Forest

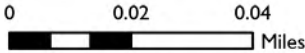

Base Image: City of Fargo Imagery (2020)



St. Paul District
GIS CENTER

US Army Corps
of Engineers®

FMM FOREST MITIGATION APPENDIX - SITE 34

Areas identified for forest mitigation
opportunities

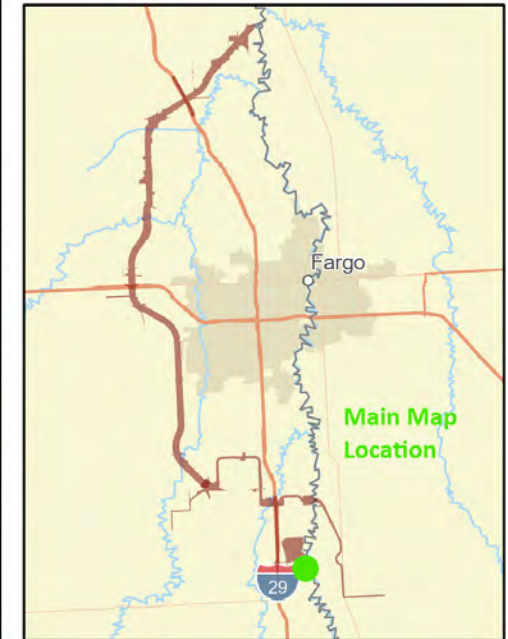

-  Parcel Boundaries
-  Diversion / Embankment Alignment
-  Floodplain Forest
-  Bank Stabilization

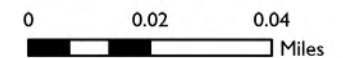

Base Image: City of Fargo Imagery (2020)



St. Paul District
GIS CENTER

US Army Corps
of Engineers ®

FMM FOREST MITIGATION APPENDIX - SITE 35

Areas identified for forest mitigation
opportunities

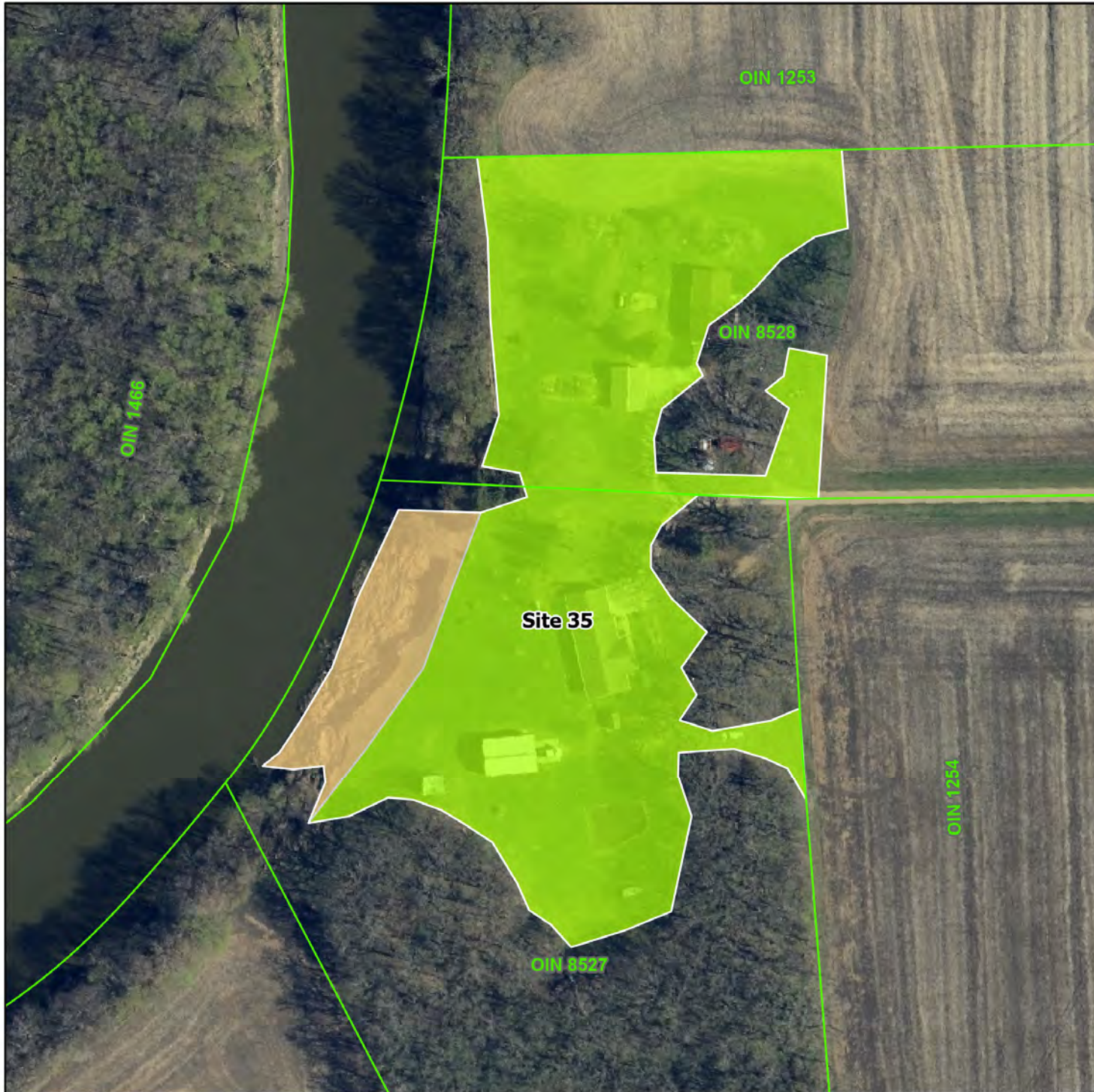

-  Parcel Boundaries
-  Diversion / Embankment Alignment
-  Floodplain Forest
-  Bank Stabilization

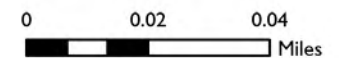

Base Image: City of Fargo Imagery (2020)



St. Paul District
GIS CENTER

US Army Corps
of Engineers®

FMM FOREST MITIGATION APPENDIX - SITE 36

Areas identified for forest mitigation
opportunities



- Parcel Boundaries
- Diversion / Embankment Alignment
- Floodplain Forest
- Bank Stabilization

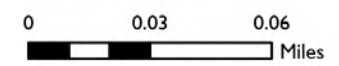

Base Image: City of Fargo Imagery (2020)



St. Paul District
GIS CENTER

US Army Corps
of Engineers®

FMM FOREST MITIGATION APPENDIX - SITE 38

Areas identified for forest mitigation opportunities



- Parcel Boundaries
- Diversion / Embankment Alignment
- Floodplain Forest
- Bank Stabilization

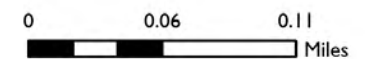

Base Image: City of Fargo Imagery (2020)







St. Paul District
GIS CENTER

US Army Corps
of Engineers®

FMM FOREST MITIGATION APPENDIX - SITE 39

Areas identified for forest mitigation
opportunities



-  Parcel Boundaries
-  Diversion / Embankment Alignment
-  Floodplain Forest
-  Bank Stabilization

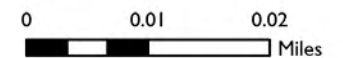

Base Image: City of Fargo Imagery (2020)

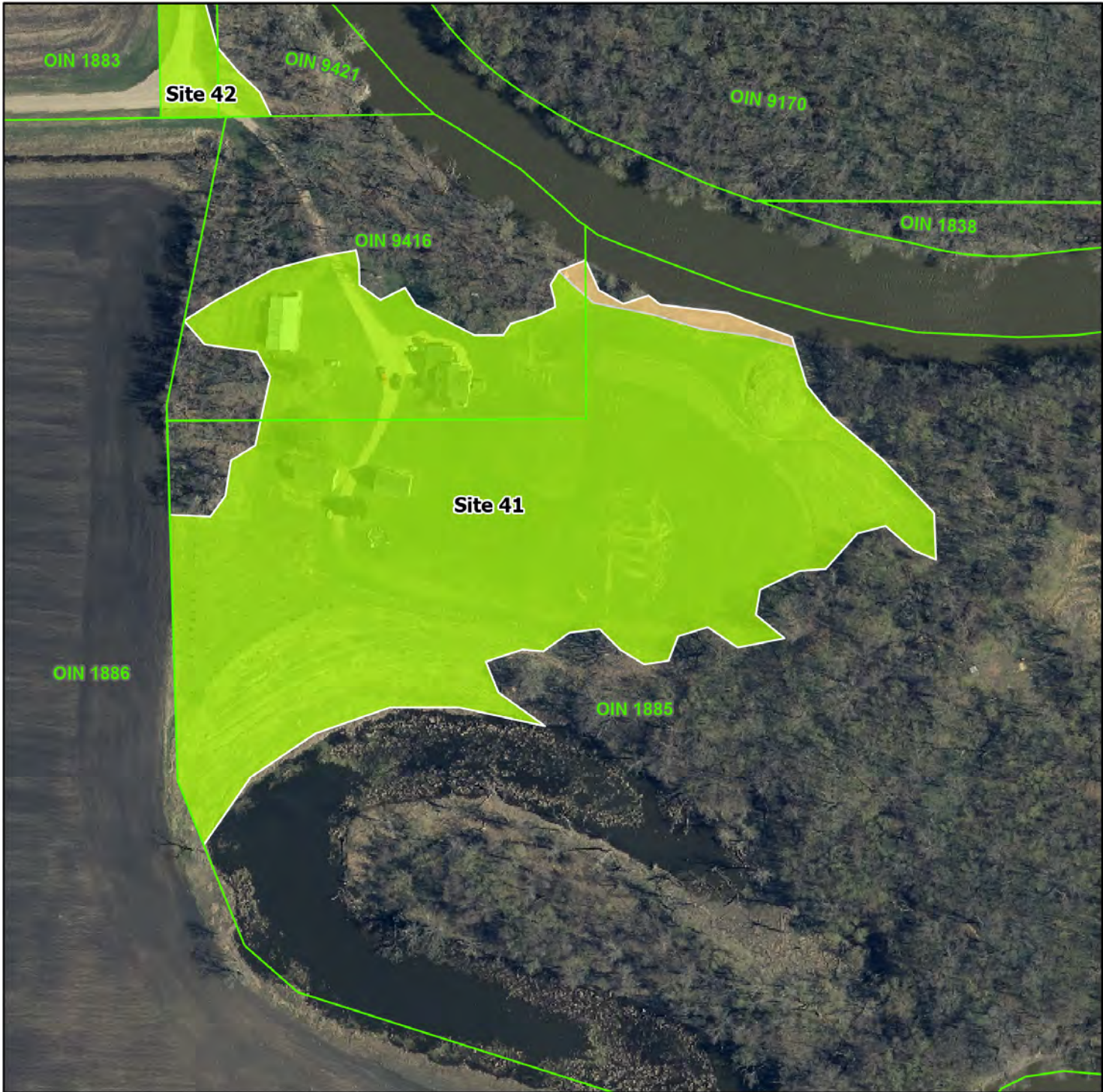





St. Paul District
GIS CENTER

US Army Corps
of Engineers®

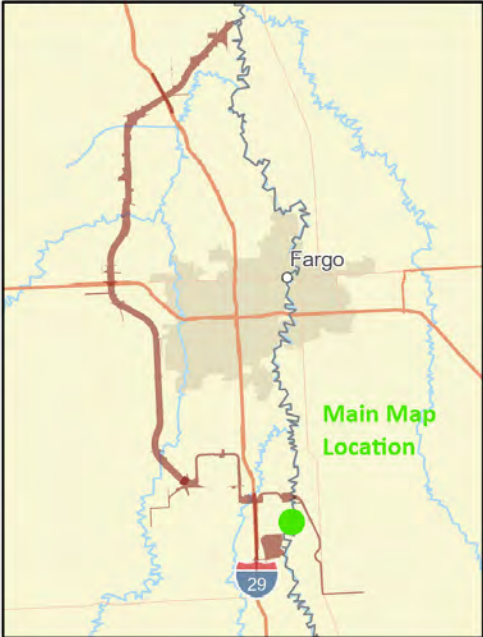
FMM FOREST MITIGATION APPENDIX - SITE 41

Areas identified for forest mitigation opportunities



-  Parcel Boundaries
-  Diversion / Embankment Alignment
-  Floodplain Forest
-  Bank Stabilization

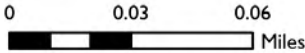

Base Image: City of Fargo Imagery (2020)

Created by: bdpdtk9 4/13/2023 4:50 PM
P:\SA\SA_FT\1_Environmental_402798\FMM Mitigation_Environmental\Forest\GIS_Support\APR\X\FM14_Forest_Mitigation_Mapbook_20230328.aprx



St. Paul District
GIS CENTER

US Army Corps
of Engineers®

FMM FOREST MITIGATION APPENDIX - SITE 42

Areas identified for forest mitigation opportunities



- Parcel Boundaries
- Diversion / Embankment Alignment
- Floodplain Forest
- Bank Stabilization

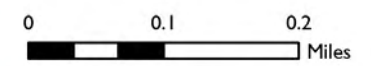

Base Image: City of Fargo Imagery (2020)





St. Paul District
GIS CENTER

US Army Corps
of Engineers®

FMM FOREST MITIGATION APPENDIX - SITE 43

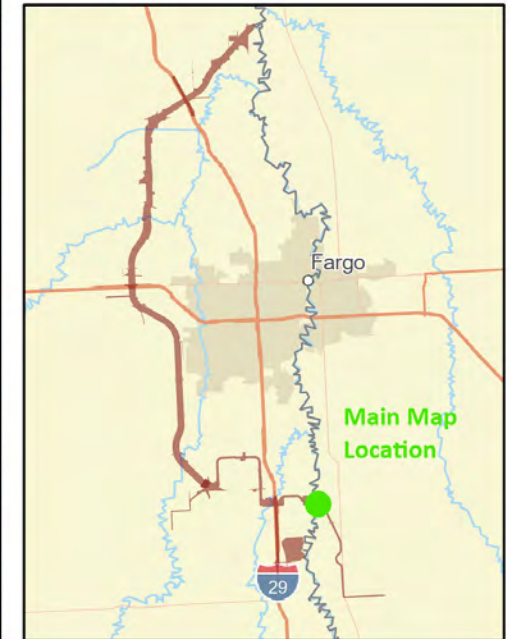
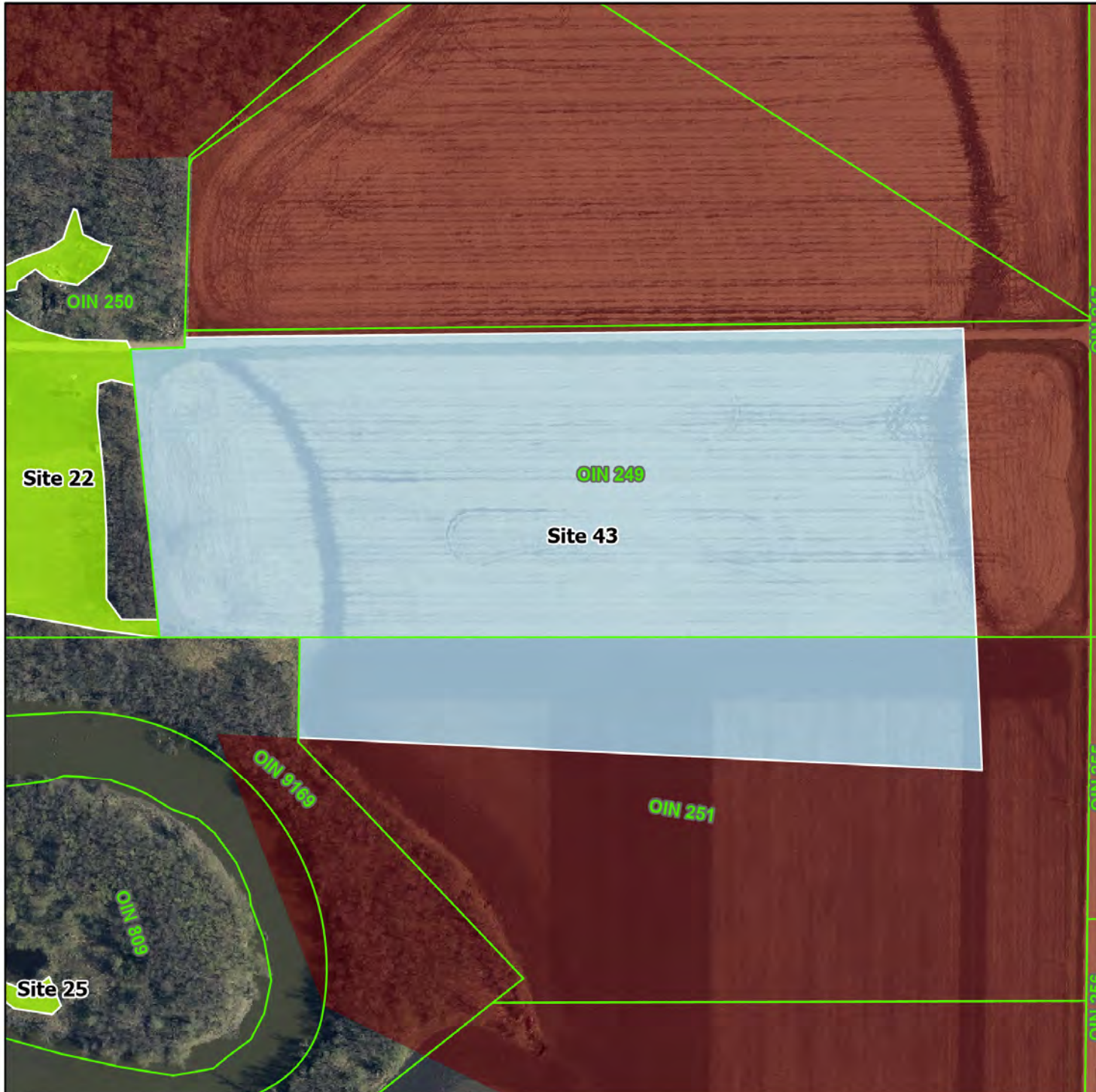
Areas identified for forest mitigation opportunities



-  Parcel Boundaries
-  Diversion / Embankment Alignment
-  Floodplain Forest
-  Oak Savanna

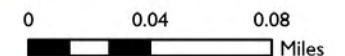

Base Image: City of Fargo Imagery (2020)

Appendix E

Survey Protocols

Plot Density

The number of survey plots will be dependent on the size of the site. Smaller sites have a higher density to adequately be able to assess the site. Conditions of larger sites can be generalized with less plots per acre. The following table should be used to determine the number of plots required. Plots will be placed randomly across the mitigation property with a 66 foot buffer around each point to avoid overlap. Each survey year plots will be re-randomized in order to ensure greater coverage of the sites.

Size of Site	Number of Plots
under 1 acre	3
1 to 5 acres	6
5 to 20 acres	1 plot per acre
20+ acres	1 plot per acre up to 20 and then 1 plot for every 5 acres after that (ex. 45 acre planting would be 23 plots)

Seedling Survival:

Step 1: In the field, determine the orientation of the planting rows that will be sampled and sample the entire planting based on this orientation. Rows may be north-south, east-west or at other bearings. Based on the selected orientation, identify the random point nearest to the extreme corner of the planting (e.g., for a north-south planting, this would be the point closest to the northwest corner) as the first transect point. Navigate to that point, but do not worry about being exactly on the point.

Step 2: Once at the point, locate the nearest planted tree. The nearest planted tree will be the first tree measured in the transect. A quick determination of the closest tree is all that is needed. Record the species, what type of stock, whether it is dead or alive, its height and whether it is planted snugly in the ground.

Step 3: Once data has been collected on the first tree, continue sampling along the transect in the direction of travel, until the total number of trees per transect have been surveyed, as described in the figure below. The orientation of travel should remain the same as determined in Step 1, however, you may travel in either of the two cardinal directions to complete transects (i.e., in a north-south planting, transects may be completed either going north or going south, but should not be completed in an east to west orientation). It is very important to stop at each point along a transect based on the spacing of the planting and make a record of no trees in planting locations that are empty. Diagram A1 in Appendix A provides a visual representation of transect layout.

Step 4 Once the final tree has been surveyed in the transect, proceed to the nearest random point at which a transect has not been completed. Follow Steps 2 and 3 to complete the next and all subsequent transects.

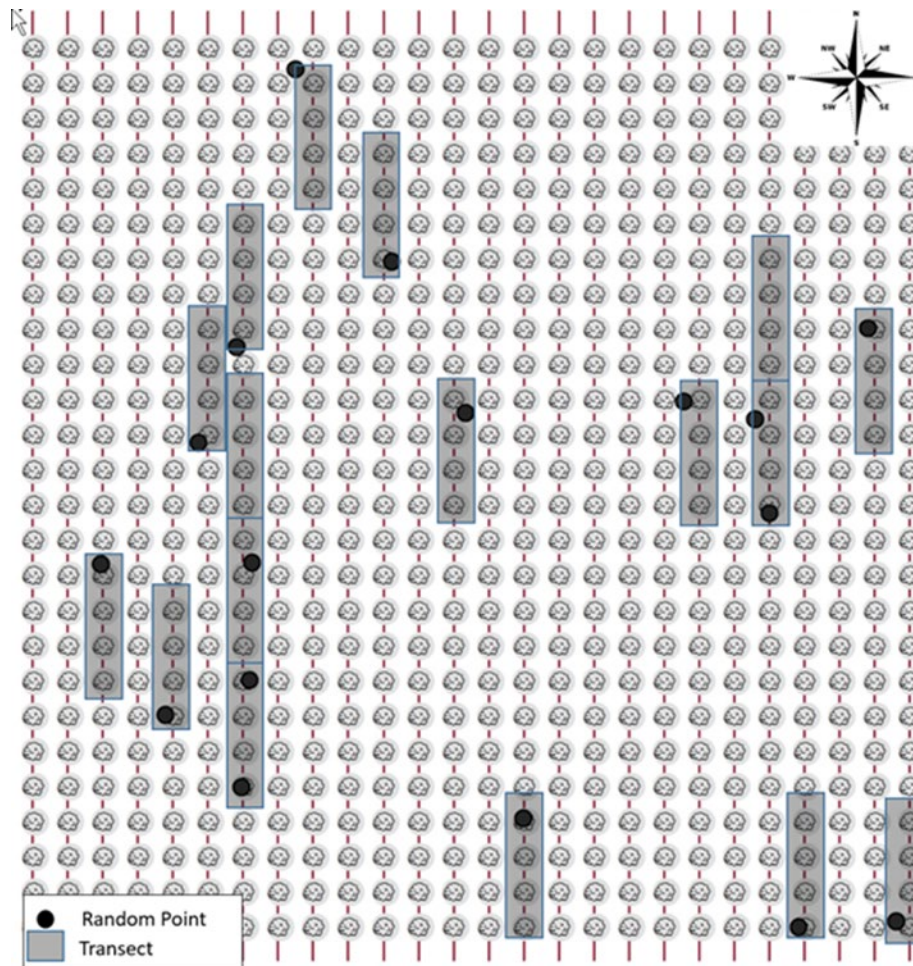

Percent cover surveys:

The amount of area a specific species takes up in a set space. A specific species cannot exceed 100% cover of an area, but a specific area can have greater than 100% cover of all species combined.

Using a 1 meter squared quadrat place it on the ground over your sampling point.

Start by identifying the species that are present within the plot and determine whether they are invasive. Once all invasive species have been identified and recorded start to determine the percent area that the species takes up within the plot, use the figure below as an example. Every species receives its own percent cover calculation.

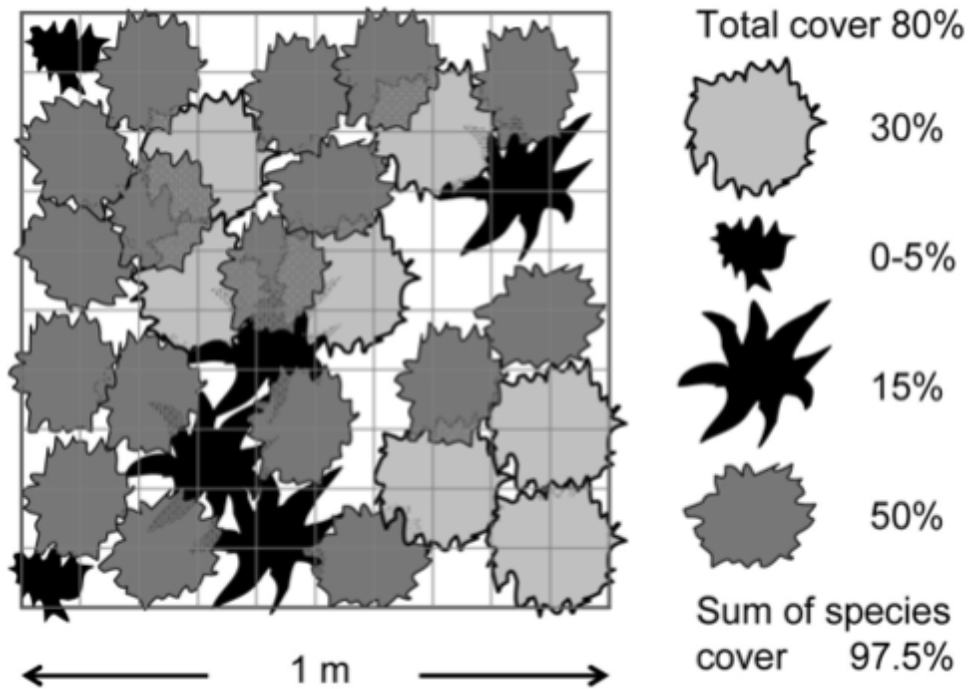

In years that include both percent cover surveys and seedling surveys, plots will be nested within one another as shown in the diagram below. In years when percent cover surveys are the only ones performed, percent cover survey plots will be placed at random as described in section 7.1 Monitoring Requirements.

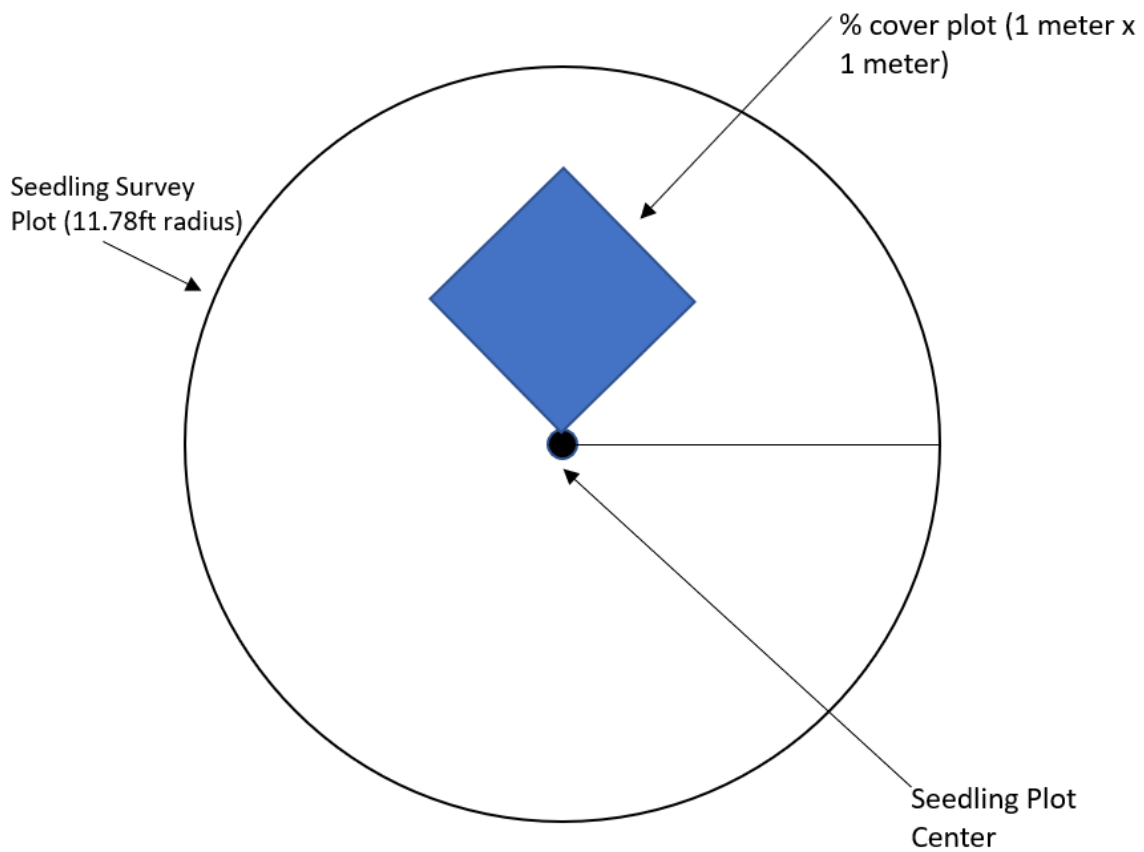

Seedling Survey:

Using a circular 0.01 acre plot, establish a plot perimeter and plot center. This is best done using a string, chain or rope that is cut to the length of the radius of the plot circle (11.78 feet). Once plot center is established begin identifying all woody stems in the plot and identify them to species and record their heights. When all seedlings are identified and measured multiple the total tally by 100 to determine the number of stems per acre.

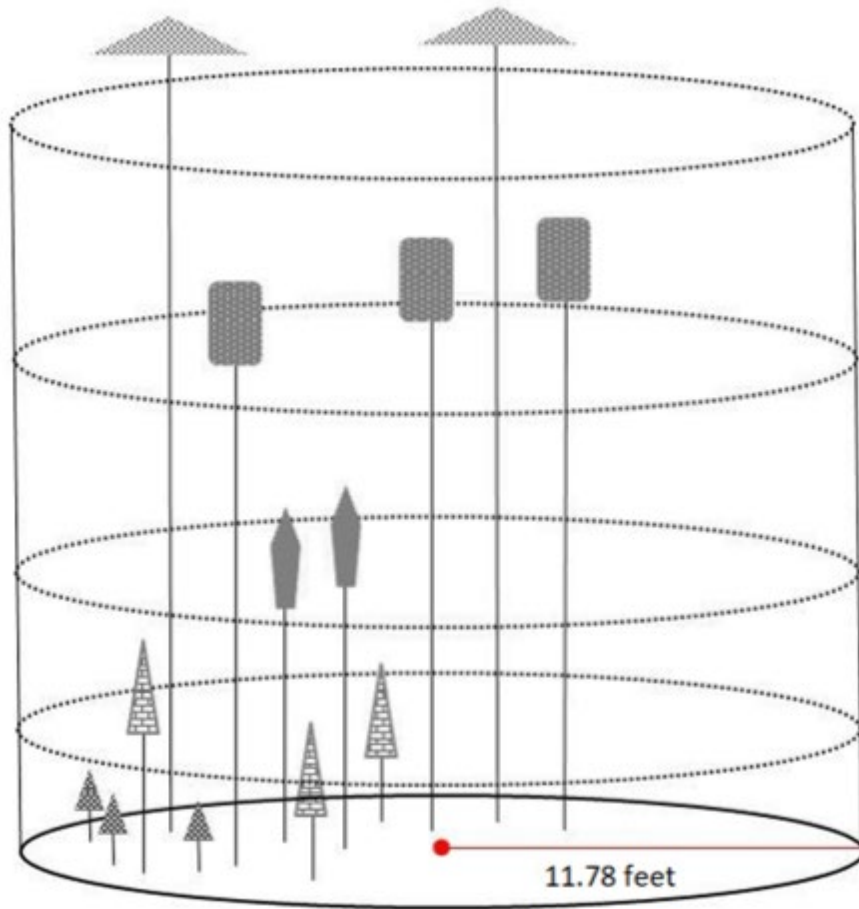

Forest Inventory Survey:

Using a 10 factor prism center it over the center of your plot. Identify the first tree that you will count. Record whether that tree is in or out, if the tree is “in” determine the species that it is and record it. If the tree is “out” do not record it and move to the next tree. An “out” tree will not overlap within the prism. An “in” tree will have some overlap within the prism (see the figure). Following the recording of that tree continue spinning the prism over plot center tallying trees in or out as you go. When all trees in the plot have been sampled, then add up the total number of trees counted and multiply by 10 to calculate the total basal area of the plot.

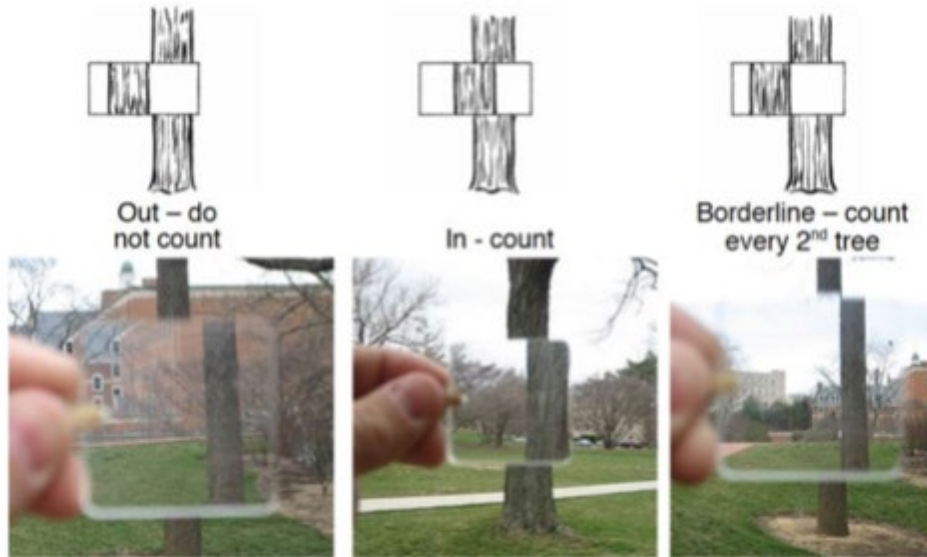

Canopy cover will be determined through means of ocular estimation in increments of 10 percent for trees in coverage area over a 0.01 ac plot (11.78 ft. radius) centered at the prism plot center. Canopy cover is estimated as the percent of the sky that is covered by tree leaves and branches when looking up through the canopy. For trees per acre, below is a screenshot of the methods to calculate trees per acre from a BAF 10 prism plot.

Calculating Trees Per Acre from BAF 10 Variable Radius Plots

Trees per plot

$$TPA_{plot} = \sum_{i=1}^t \frac{1}{\pi \cdot (dbh_t \times 2.75)^2 / 43560} \text{ where } t = \text{each individual tree within a plot}$$

Or

$$TPA_{plot} = \sum_{i=1}^t \frac{10}{0.005454 \cdot (dbh_t)^2} \text{ where } t = \text{each individual tree within a plot}$$

Trees per stand (or other summary level)

$$TPA_{stand} = TPA_{plot} / n \text{ where } n = \text{the number of plots in the stand}$$

TABLE 10-8 Derivation of the Basal Area Factor of 10 Sq Ft Per Acre for Point Sampling

Tree dbh, in. (1)	Imaginary plot radius, ft. (2)	Imaginary plot size, acres (3)	Trees per acre,* no. of stems (4)	Basal area per tree, sq ft (5)	Basal area per acre, sq ft (6)
4	11.00	0.0087	114.94	0.087	10
6	16.50	0.0196	51.02	0.196	10
8	22.00	0.0349	28.65	0.349	10
10	27.50	0.0545	18.35	0.545	10
12	33.00	0.0785	12.74	0.785	10
14	38.50	0.1069	9.35	1.069	10
16	44.00	0.1396	7.16	1.396	10
18	49.50	0.1767	5.66	1.767	10
20	55.00	0.2182	4.58	2.182	10
22	60.50	0.2640	3.79	2.640	10
24	66.00	0.3142	3.18	3.142	10
26	71.50	0.3687	2.71	3.687	10
28	77.00	0.4276	2.34	4.276	10
30	82.50	0.4909	2.04	4.909	10
32	88.00	0.5585	1.79	5.585	10
34	93.50	0.6305	1.59	6.305	10
36	99.00	0.7069	1.41	7.069	10
Method of calculation	dbh × 2.75	$\frac{\pi r^2}{43,560}$	$\frac{1.03}{\text{plot size}}$	0.0054547 ²	column 4 × 5

* Exact value for number of trees per acre may vary slightly, depending upon number of decimal places expressed for imaginary plot size.

```
Python: 1/((math.pi*(!TR_DIA!*2.75)**2/43560))
Excel: =ROUND(1/(PI()*(!TR_DIA*2.75)^2/43560),2)
```

Appendix F

Stocking Guidelines

Floodplain Forest Stocking Benchmarks	
Year Since Planting	1
Total trees per acre natural and planted >6 inches tall	>1200 trees per acre
Total Shrubs per acre natural and planting >6 inches tall	>200 stems per acre
Planted trees >12 inches tall	>400 trees per acre
Year Since Planting	3
Total trees per acre natural and planted >24 inches tall	>900 trees per acre
Total shrubs per acre natural and planted >12 inches tall	>150 stems per acre
Planted trees >36 inches tall	>300 trees per acre
Year Since Planting	6
Total trees per acre natural and planted >54 inches tall	>500 trees per acre
Total shrubs per acre natural and planted >36 inches tall	>75 stems per acre
Planted trees >60 inches tall	>200 trees per acre
Year Since Planting	10
Total trees per acre > 2 inches at DBH	>300 trees per acre

Oak Savannah Benchmarks	
Year Since Planting	1
Total trees per acres of planted seedlings >24 inches tall	>300 trees per acre
Total trees per acre of containerized trees >48 inches tall	>240 trees per acre
Year Since Planting	3
Total trees per acres of planted seedlings >48 inches tall	>260 trees per acre
Total trees per acre of containerized trees >60 inches tall	>200 trees per acre
Year Since Planting	6
Total Trees per acre of planted seedlings >60 inches tall	>240 trees per acre
Total trees per acre of containerized trees >80 inches tall	>170 trees per acre
Year Since Planting	10
Total trees per acres >3 inches at DBH	>170 trees per acre

Appendix G

Monitoring Period Tasks

Monitoring Year	All Sites				Flood Plain Forest Sites		Oak Savanna Sites	
	Inspect site for invasive species encroachment	Inspect site for land encroachments (herbicide drift, agricultural tillage, neighboring landowner encroachments, etc.)	Planting survival surveys	Check Trees Per Acre/ stem densities on sites (counting planted and natural seedlings) using either seedling surveys or overstory inventory surveys	Check species Diversity (planted and natural)	% cover surveys for herbaceous species	Conduct canopy cover surveys to ensure site is on track	% cover surveys for herbaceous species
Annually to year 5	x	x						
Year 1			x	x		x		x
Year 3				x		x		x
Year 6	x	x		x	x	x	x	x
Year 10	x	x		x	x	x	x	x
Year 15 and every 5 thereafter	x	x		x			x	

Fargo-Moorhead Metropolitan Area Flood Risk Management Project

Draft Adaptive Management and Mitigation Plan



**US Army Corps
of Engineers®**
St. Paul District

November 2022



FM AREA
DIVERSION

Document History

Version	Date	Description of Changes
2011 EIS Version (Attachment 6)	July 2011	NA
2019 SEA Version (Appendix G)	February 2019	NA
AMT Version #1	November 2021	First version with AMT consensus.
AMT Version #2	November 2022	Draft version for AMT review

DRAFT

Table of Contents

Document History.....	2
INTRODUCTION	7
1. OVERVIEW OF ADAPTIVE MANAGEMENT IMPLEMENTATION PROCESS.....	11
1.1. Introduction to Adaptive Management Approach.....	11
1.2. Project Adaptive Management and Monitoring Plan Participation	12
1.3. Goals, Objectives, and Performance Standards	13
1.4. Development and Implementation of Monitoring Plans.....	13
1.5. Resource Management Team Process	14
1.6. Adaptive Management Team Process.....	15
1.7. Consideration of the Adaptive Management Team Recommendations by Non-Federal Sponsors and the USACE.....	18
2. PROJECT IMPACTS AND MITIGATION NEEDS.....	19
2.1. Aquatic Habitat	20
2.2. Floodplain Forest.....	21
2.3. Wetlands	21
2.4. Geomorphology	22
2.5. Invasive Species Management.....	23
2.6. Aquatic Connectivity	23
3. PROJECT MITIGATION	25
3.1. Aquatic Habitat	25
3.1.1. Aquatic Habitat Mitigation in Minnesota	25
3.1.2. Aquatic Habitat Mitigation in North Dakota.....	26
3.2. Forests	27
3.3. Wetlands	28
3.3.1. Wetland Impacts Addressed in the US Army Corps of Engineers Permit No. NWO-2013-1723-BIS.....	28
3.3.2. Wetland Impacts Addressed in the US Army Corps of Engineers Permit No. NWO-2014-0236-BIS.....	28
3.3.3. Wetland Impacts from the Southern Embankment and Associated Infrastructure	28
3.4. Aquatic Connectivity	29
3.5. Additional Considerations to Minimize Impacts and Mitigation Needs	30

4.	MONITORING, PERFORMANCE STANDARDS, and TRIGGERS	34
4.1.	Aquatic Habitat and Connectivity	35
4.2.	Floodplain Forest Habitat.....	41
4.3.	Wetland Habitats	43
4.4.	Geomorphic.....	47
4.5.	Water Quality	54
4.6.	Invasive Species Monitoring	55
4.7.	Fish Stranding.....	56
4.8.	Drayton Dam	60
4.9.	Additional monitoring needs	61
5.	Costs and Schedules.....	62
5.1.	Monitoring Schedule and Costs.....	62
6.	Data Storage	67
7.	References:.....	68

DEFINITIONS FOR ABBREVIATIONS AND TERMS USED IN THE AMMP

Abbreviation/Term	Definition
2011 FEIS	Final Feasibility Report and Environmental Impact Statement, Fargo-Moorhead Metropolitan Area Flood Risk Management, July 2011
2013 SEA	Supplemental Environmental Assessment, dated September 2013
2016 MN EIS	Final Environmental Impact Statement by the Minnesota Department of Natural Resources
2019 SEA	Supplemental Environmental Assessment #2
AAHU	Average Annual Habitat Unit
Ac	acre
ADCP	Acoustic Doppler Current Profiler
AMMP	Adaptive Management and Mitigation Plan
AMT	Adaptive Management Team
BRRWD	Buffalo-Red River Watershed District
BWSR	Minnesota Board of Water and Soil Resources
CEQ	Council on Environmental Quality which includes the NEPA Task Force
DBH	Diameter (of tree) at breast height
DOC	Dissolved Organic Carbon
EPA	U.S. Environmental Protection Agency
GMP	Geomorphic Monitoring Plan
GMT	Geomorphic Monitoring Team
HEP	USFWS Habitat Evaluation Procedures
HSI	Habitat Suitability Index
HU	Habitat Unit
IBI	Index of Biotic Integrity
LOTR	Lower Otter Tail River
MnDNR	Minnesota Department of Natural Resources
MnPCA	Minnesota Pollution Control Agency
MnRAM	Minnesota Routine Assessment Method
NEPA	National Environmental Policy Act
NDDEQ	North Dakota Department of Environmental Quality, previously the North Dakota Department of Health
NDDWR	North Dakota Department of Water Resources, previously the North Dakota State Water Commission
NDGF	North Dakota Game and Fish
NDSWC	North Dakota State Water Commission
Non-Federal Sponsors	City of Fargo, North Dakota; City of Moorhead, Minnesota; and Metro Flood Diversions Authority
NNI	Native, non-invasive Species
NRCS	Natural Resources Conservation Service
OHB	Oxbow-Hickson-Bakke
O&M	Operations and Maintenance

Abbreviation/Term	Definition
OMRR&R	Operations, Maintenance, Repair, Rehabilitation, and Replacement
Post-construction	Once the Project has received all approvals and is officially operational the status of the Project will be considered post-construction.
PRAM	Property Rights Acquisition Mitigation
Project	Fargo-Moorhead Metropolitan Area Flood Risk Management Project
Project Operation	Operation of the Red River Structure, Wild Rice River Structure, and Diversion Inlet Structure in response to a flood that generated a combined Red River and Wild Rice River flow exceeding 21,000 cfs, as measured at the Red River at Enloe, ND, and Wild Rice River at Abercrombie, ND, USGS gages.
Section 404 Permit	Permits issued in accordance with Section 404 of the federal Clean Water Act
SIR	USGS Scientific Investigation Reports
TOC	Total Organic Carbon
USACE	St. Paul District, U.S. Army Corps of Engineers
USFS	U.S. Forest Service
USFWS	U.S. Fish and Wildlife Service
USGS	U.S. Geological Survey
WCA	Minnesota Wetland Conservation Act
WQM	Water Quality Monitoring Study
WRRDA	Water Resources Reform and Development Act of 2014

INTRODUCTION

The Fargo-Moorhead Metropolitan Area Flood Risk Management Project (Comprehensive Project) was authorized by Section 7002 of the Water Resources Reform and Development Act of 2014 (WRRDA). The purpose of the Project is to reduce flood risk, flood damages, and flood protection costs related to flooding in the Fargo-Moorhead metropolitan area. The Project is led by the St. Paul District, United States Army Corps of Engineers (USACE), and the non-federal sponsors of Fargo, North Dakota; Moorhead, Minnesota; and the Metro Flood Diversion Authority (Authority) (collectively Non-Federal Sponsors). The Authority was formed as the lead Non-Federal Sponsor and is the point of contact for the Non-Federal Sponsors.

The Comprehensive Project is located in the Fargo-Moorhead Metropolitan Area (Figure 1). The Comprehensive Project consists of:

- Stormwater Diversion Channel System and Associated Infrastructure (SWDCAI): Delivered by the Red River Valley Alliance, the P3 developer for the project, the SWDCAI includes a 30-mile Diversion Channel, a Diversion Outlet, and aqueducts on the Maple and Sheyenne Rivers. There also will be 14 drainage inlets, three railroad crossings, two interstate crossings, and 12 county road crossings.
- Southern Embankment and Associated Infrastructure (SEAI): Delivered through the USACE and contractors, the SEAI includes a 20-mile Southern Embankment and three gated control structures: the Diversion Inlet Structure, Wild Rice River Structure, and Red River Structure. Each structure will have large radial-arm gates that will raise and lower during project operations to control flooding. The SEAI also involves constructing several transportation features, including an I-29 bridge crossing, county and township road crossings, and a 4-mile grade raise on I-29.
- Local Entity Flood Protection and Associated Infrastructure (LFPAI): City and county governments are working on in-town protection measures, including levees, floodwalls and stormwater lift stations as well as some road work throughout Cass and Clay Counties and in the cities of Fargo and Moorhead.
- Mitigation Features and Associated Infrastructure (MFAI): The USACE as well as city and county governments are responsible for numerous mitigation features for the Comprehensive Project. This includes the Upstream Mitigation Area where flowage easements will be acquired, property/structures will be removed, and cemeteries will undergo mitigation to protect the property and viewshed. Additionally, levees will be built for Oxbow-Hickeson-Bakke and Christine. Wetland mitigation projects as well as the Lower Otter Tail River Restoration project also will occur.

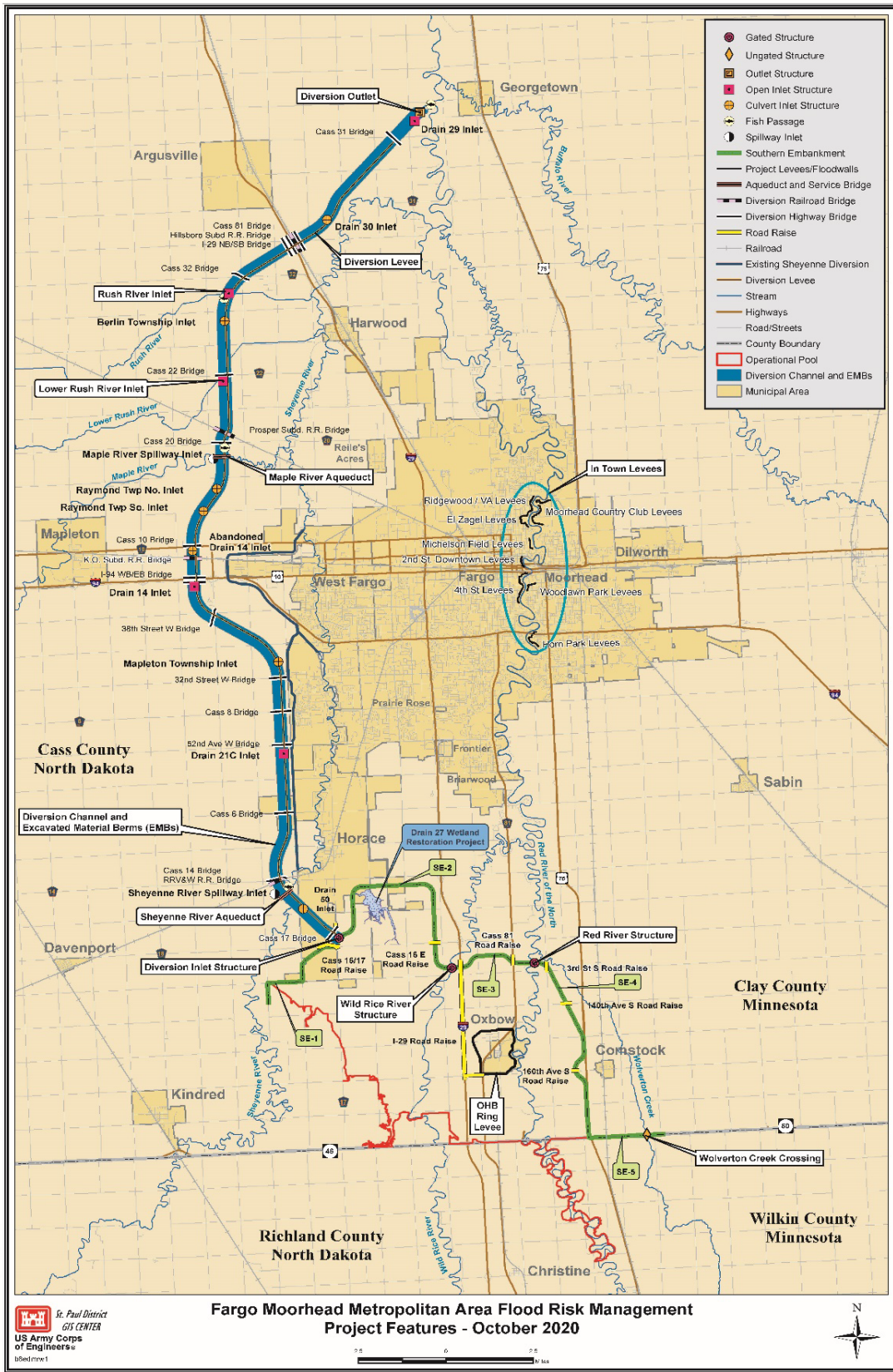

Figure 1. Map of the Project area.

The Project originated as a recommendation from the Final Feasibility Report and Environmental Impact Statement (FEIS), Fargo-Moorhead Metropolitan Area Flood Risk Management, July 2011. As outlined within the FEIS, the Project would have various environmental effects. Some of the identified effects were significant enough to warrant mitigation. These impacts and mitigation needs were updated through the Supplemental Environmental Assessment, dated September 2013 (2013 SEA), and the Supplemental Environmental Assessment #2 (2019 SEA). The Project with all proposed modifications included in the 2013 SEA and the 2019 SEA since the FEIS is referred to as "Plan B." Based on the current NEPA analysis, environmental impacts requiring mitigation would include impacts to aquatic habitat, riparian forest, and wetland resources. For these impacts, mitigation will be implemented to offset these adverse effects to the greatest extent practicable. Mitigation is also being included to address concerns of state natural resource agencies regarding biological connectivity. Conversely, other resource types or functions were not deemed to have significant impacts but warrant monitoring to ensure impacts stay within those outlined in the NEPA analysis. These include monitoring of river geomorphology, water quality, and fish stranding. Mitigation of nonenvironmental impacts, such as property right mitigation, are not addressed in this document. A property rights acquisition mitigation plan (PRAM) has been developed for the Project and provides details on property rights mitigation.

Summary of Adaptive Management and Mitigation Plan Sections

The NEPA analysis included impact analyses of changes in habitat quality and quantity. The NEPA analysis also included mitigation measures for to reduce significant adverse impacts. The purpose of this Adaptive Management and Mitigation Plan (AMMP) is to provide a dynamic framework and adaptive approach to monitoring potential impacts over time and mitigation associated with the Project. The AMMP also discusses possible approaches if mitigation measures do not result in projected conditions, or if unforeseen impacts arise from implementation of the Project.

Section 1 provides an overview of the adaptive management and implementation process, including the collaboration process with the Non-Federal Sponsors, USACE, State of North Dakota, State of Minnesota, and federal natural resource agencies.

Section 2 provides an overview of Project impacts and mitigation needs focusing on habitat-based assessments of impacts and mitigation needs for aquatic habitat, forest, and wetland resources.

Section 3 provides an overview of the Project mitigation approach, a summary table of mitigation needs, mitigation accomplished to date, and remaining mitigation needed. Specific mitigation sites have not been fully finalized for all impact needs as the Project design details have not been completed. The USACE has identified several mitigation projects, as described in Section 3, and will continue to refine specific mitigation plans during detailed Project design.

Section 4 describes specific monitoring activities that will be completed pre- and post-construction, performance standards, and triggers for event-specific monitoring and adaptive management. This section also includes overviews on contingency processes where corrective action could be pursued if mitigation proves to be less effective than anticipated.

Section 5 provides the anticipated cost and schedule of monitoring and mitigation efforts.

Section 6 addresses the storage and accessibility of data collected by the monitoring activities.

Collectively, this AMMP will drive the implementation of mitigation, and the data collection and review processes to confirm the effectiveness of the mitigation. Monitoring results will be compared to the environmental changes that would occur due to Project implementation with mitigation to verify whether the impacts of the Project have been appropriately offset. In addition, this AMMP will remain flexible to adapt to the needs of the Project over time. As such, this document is open to change throughout the life of the Project.

1. OVERVIEW OF ADAPTIVE MANAGEMENT IMPLEMENTATION PROCESS

1.1. Introduction to Adaptive Management Approach

Adaptive management is based upon clearly identified outcomes, as described in environmental documentation, monitoring to determine if the desired outcomes occur, and, if not, facilitating management changes to either meet or re-evaluate the projected outcomes (DOI, 2018). Adaptive Management is a requirement of Minnesota Dam Safety & Public Waters Work Permit number 2018-0819 ("MnDNR Permit No. 2018-0819") and USACE Policy Guidance for those civil works programs that require environmental mitigation. This Adaptive Management and Monitoring Plan recognizes that recommendations generated by the Adaptive Management Approach remain subject to federal and state laws, permit conditions, and the permit amendment/regulatory oversight process is expressly reserved to permitting agencies having jurisdiction over various elements of the Comprehensive Project.

Adaptive management is a "learning by doing" management approach which promotes flexible decision making that can be adjusted when there are uncertainties that will become more defined as outcomes from management actions and other events become better understood (National Academy of Sciences, 2004). It is used to address the uncertainties often associated with complex, large-scale projects. In adaptive management, a structured process is used so that the "learning by doing" is not simply a "trial and error" process (Walters, 1986).

The basic elements of an adaptive management process are: (1) assess; (2) design; (3) implement; (4) monitor; (5) evaluate; and (6) adjust. In practice, adaptive management is implemented in a non-linear sequence, in an iterative way, starting at various points in the process and repeating steps based on improved knowledge.

Application of adaptive management should occur in two phases. A setup phase would involve the development of key components, and an iterative phase would link these components in a sequential process. Elements of the setup phase include stakeholder involvement, defining management or mitigation objectives, identifying potential management or mitigation actions, identifying or building predictive modeling or assessment tools, specifying performance measures and/or risk endpoints, and creating monitoring plans. In addition, values for the monitored measures that would trigger adaptive management should be determined in this phase. The second iterative phase uses these elements in an ongoing cycle of learning about system structure and function, followed by managing based on what is learned from data collected. The elements of the iterative phase include recommendations, follow-up monitoring, collaborative approaches on future actions, and subsequent assessment.

Adaptive management is not necessarily the only decision-making process. Adaptive management provides a systematic methodology that could lead to enhanced benefits and effective outcomes (DOI, 2018).

Adaptive management should not be used where decisions can only be changed in a limited manner or cannot be changed due to permit requirements. Federal permits include the Section 404 Permit, Rivers and Harbors Act of 1899 Sections 9 and 10 Permit, Programmatic Agreement under the National Historic Preservation Act Section 106, U.S. Fish and Wildlife Coordination Act Report

compliance, and Prime and Unique Farmlands Protection Act Consultation Compliance. North Dakota permits include Section 401 Permit, North Dakota Sovereign Lands Permit, North Dakota Construction Permits, North Dakota Dewatering Permits, and North Dakota stormwater pollution prevention plan permits. Minnesota permits include MnDNR Permit No. 2018-0819 and Minnesota stormwater pollution prevention plan permits. In addition, the Non-Federal Sponsors have permits and agreements with local agencies and entities that manage land use, flood control, transportation, and utilities along the construction corridor (Local Permits). This AMMP does not address compliance with Local Permits.

The overall adaptive management process generally includes:

- Identification of Project Adaptive Management and Monitoring Plan Participation
- Establishment of Goals, Objectives, and Performance Standards – specifically for those items that are not fully defined in the environmental documentation due to future uncertainties
- Development and Implementation of Monitoring Plans – to determine realization of goals and objectives as defined in the environmental documentation
- Resources Monitoring Team Process – to provide a group of technical experts to review monitoring plan results; compare with goals, objectives, and performance standards; and develop recommendations based upon scientific analyses
- Adaptive Management Team Process – to review the results of the Resources Monitoring Team recommendations to determine “next steps” to achieve goals, objectives, and performance standards
- Consideration of the Adaptive Management Team Recommendations by the USACE and Non-Federal Sponsors
- In accordance with MnDNR Permit No. 2018-0819, the Adaptive Management Team will meet within 30 calendar days of the identification of a trigger set forth in this Adaptive Management and Monitoring Plan and provide a corrective action recommendation within 30 calendar days of the meeting of the Adaptive Management Team.

1.2. Project Adaptive Management and Monitoring Plan Participation

Staff from multiple state and federal resource agencies have been involved in the planning process for the Project dating back to 2009. Agency input has been instrumental in the calculation of Project impacts, the identification and design of mitigation efforts, and the development of monitoring procedures. Individuals that attended meetings on the AMMP eventually became known informally as the Adaptive Management Team (AMT).

Agencies that have participated in AMT meetings include, but are not limited to, the following:

- U.S. Army Corps of Engineers (USACE),
- Non-Federal Sponsors (Metro Flood Diversion Authority, City of Fargo, and City of Moorhead),
- U.S. Fish and Wildlife Service (USFWS),
- U.S. Geological Survey (USGS),
- U.S. Forest Service (USFS),

- Environmental Protection Agency (EPA),
- Natural Resources Conservation Service (NRCS),
- North Dakota Game and Fish (NDGF),
- North Dakota Department of Environmental Quality (NDDEQ), previously the North Dakota Department of Health (NDDoH),
- North Dakota Department of Water Resources (NDDWR), previously North Dakota State Water Commission (NDSWC),
- Minnesota Department of Natural Resources (MnDNR),
- Minnesota Pollution Control Agency (MPCA), and
- Minnesota Board of Water and Soil Resources (BWSR).

Several smaller groups of technical experts were eventually formed to discuss monitoring and adaptive management in greater depth with the intent of providing focused recommendations to the AMT. Those teams included the Geomorphic Monitoring Team, the Water Quality Monitoring Team, Wetlands Monitoring Team, Forestry Monitoring Team, and the Biotic Monitoring Team.

1.3. Goals, Objectives, and Performance Standards

Clearly focused and quantitative goals and objectives are essential to adaptive management. They should be logically linked to mitigation actions, performance standards, and monitoring activities. Goals and objectives will be specifically identified during detailed monitoring and mitigation planning.

Performance standards will be used during two adaptive management processes: plan evaluation (evaluation of performance measures and metrics like those described above to predict Project impacts) and assessment of actual plan performance (assessment of performance measures following Project implementation). In many cases, these processes would be the same, allowing predictions to be compared to actual responses.

Performance standards are further discussed in Section 4. This includes metrics for quantifying impacts following Project construction, identification of trigger values that would indicate the need for adaptive management, and how effectiveness of future changes will be measured. These standards have been developed based on the best available information and input from the AMT. Additional data and changes in design may lead to further development or modification of performance standards. At a minimum, the goal of mitigation that has been identified as of the date of the AMMP will be to replace the habitat lost through Project impacts. Future monitoring may include additional minimum goals related to Project impacts, including but not limited to, geomorphology, fish stranding, and invasive species. Performance standards will allow for the evaluation of mitigation effectiveness.

1.4. Development and Implementation of Monitoring Plans

The Council on Environmental Quality (CEQ) NEPA Task Force (CEQ 2003) suggests that the effectiveness of adaptive management hinges upon an effective monitoring program to establish objectives, thresholds, and baseline conditions. This will be achieved through a stepwise process that includes, as appropriate, pre-construction and post-construction studies. It is recognized that

Project level monitoring by the USACE during construction may be limited due to the availability of federal funds based on Congressional appropriations; the Non-Federal Sponsors acknowledge that in the event that the USACE does not receive Congressional appropriations, monitoring at the expense of the Non-Federal Sponsors will be required by the permits. Post-project construction monitoring will be a part of Project implementation, with monitoring required from the Non-Federal Sponsors as a part of Project operation and maintenance.

Following the adaptive framework of this document, changes would be monitored over time, and performance of measures would be assessed to determine whether additional avoidance, minimization, or mitigation measures are needed. Post-project monitoring results will provide information that can be compared with pre-project monitoring to assess the extent of impacts from the Project features and evaluate the effectiveness of mitigation. Monitoring activities, including review of results, will be performed collaboratively with the AMT.

Pre- and post-project monitoring is discussed in greater detail below in Section 4. Specific proposed sampling methodologies have been designed with input from the AMT to address the performance standards outlined.

1.5. Resource Management Team Process

Several resource areas have been identified for monitoring and adaptive management through the development of the AMMP. Each of these resource areas is very complex and technical expertise will be needed to assist the AMT in making recommendations. Resource monitoring teams for geomorphology, biotic, wetlands, forests, and water quality will meet when data related to the performance standards/metrics listed in Section 4 have been collected and are ready for evaluation or when adaptive management triggers have been reached. Each team will be responsible for making recommendations to the AMT. It is recognized that any individuals participating on behalf of MnDNR as part of a resource monitoring team will not be providing recommendations and/or ratings, but may provide comments and observations.

In the State of Minnesota, MnDNR is responsible for ensuring any mitigation proposed by the Metro Flood Diversion Authority based upon recommendations by the AMT, meets the requirements of Minnesota law and is in compliance with MnDNR Permit No. 2018-0819. Participation by any individuals participating on behalf of MnDNR in a consensus process is not compatible with regulation of the Project by MnDNR. Any determinations on whether mitigation is needed or sufficient under MnDNR Permit No. 2018-0819 is at the sole discretion of MnDNR. MnDNR will use data generated from the AMMP process to determine if any additional mitigation is needed under MnDNR Permit No. 2018-0819. Any mitigation proposed by the Non-Federal Sponsors as a result of a recommendation by the AMT will also be evaluated for compliance with MnDNR Permit No. 2018-0819.

Recommendations from the resource monitoring teams will follow a five-point consensus rating system. Individuals participating in the resource monitoring teams will rate recommendations from 1 through 5 based on the acceptability of the actions being proposed, with a rating of 1 being unacceptable and 5 being full support. Only recommendations that receive ratings of 3 or higher from each individual participating in the discussion can move to the AMT for consideration. This

process provides a steppingstone to in-depth discussion. Individuals that provide ratings of 1 or 2 will be asked to provide rationale for those ratings and solutions that could raise their scores to an acceptable level. The intent of the process is to encourage active feedback and resolution of individual concerns. The resource monitoring team will document recommendations that were not fully supported (by members that provide ratings of 1 or 2) prior to submission of the recommendation to the AMT. The documentation of the process would be provided to the AMT, along with the final rating of each member.

1.6. Adaptive Management Team Process

Features of the Project are located solely in both North Dakota and Minnesota and along the Red River channel in both North Dakota and Minnesota. Numerous entities with various interests at several levels of government have been involved in shaping the AMMP, as listed in Section 1.2, Project Adaptive Management Team. It is important to maintain collaboration among these entities to ensure the continued integrity in the adaptive management approach. However, there is also a need to make site-specific implementation recommendations at various locations within the Project area.

The following describes a process that allows for continued collaboration but allows AMT recommendations to be made by a subset of individuals based on input from regulatory and management agencies. The initial AMT participants will be selected by each entity and will discuss recommendations to present to the Non-Federal Sponsors and the USACE (during Project construction) for decisions to change Comprehensive Project implementation or the need for changes to mitigation measures. MnDNR will select its AMT participants, but those individuals selected by MnDNR will not participate in the consensus poll regarding rating or creating recommendations of the AMT, and may, but are not required to, provide opinions and/or comments to proposed recommendations.

Changes to the AMMP will be the result of recommendations from the AMT, using the process described below. It will be each AMT members responsibility to coordinate proposed changes within their own organization and report any concerns to the AMT. Changes AMMP will undergo a similar process to the initial agency approved AMMP in September 2021.

Table 1. Initial Adaptive Management Team Representatives

Adaptive Management Team	
Agency Category	Entities
Non-Federal Sponsors	Metro Flood Diversion Authority City of Fargo City of Moorhead
Federal Agencies	USACE USFWS EPA
State of North Dakota	NDDWR NDDEQ NDGF

Adaptive Management Team	
Agency Category	Entities
State of Minnesota	MnDNR (Non-rating observer status) MPCA BWSR

The AMT can use a process for discussion and evaluation of recommendations that includes, but is not limited to the following steps:

- Use the consensus rating tool to determine the position that AMT has regarding support of the recommendations from the resource monitoring teams, such as through the use of a five-point consensus rating system. Under such a consensus rating system, individuals participating in the discussion would rate recommendations from 1 through 5 based on the acceptability of the actions being proposed, with a rating of 1 being unacceptable and 5 being full support. Only recommendations that receive all ratings of 3 or higher would move forward as recommendations for the AMT. This process provides a steppingstone to in-depth discussion. Individuals that provide ratings of 1 or 2 would be asked to provide rationale for those ratings and solutions that could raise their scores to 3 or higher. This information would be used to document items that are not fully supported (by members that provide ratings of 1 or 2) or modify the recommendations.
- The AMT may also bring additional criteria to evaluating recommendations other than those criteria advanced by the science-based technical teams. The AMT may identify essential criteria (including SMART – Specific to goal; Measurable; Attainable under conditions, capacity, feasibility; Relevant to the problem and needs to be done; Timely – can be undertaken in time to achieve the goal) / and other filters they agree on for recommendation approval.
- If a recommendation is revised by the AMT in a manner that may impact technical aspects of the recommendation, the AMT may consider requesting the appropriate Resource Management Team’s input to assure it still achieves the recommendation goals.
- Recommendations forwarded to the Non-Federal Sponsors and the USACE should include information regarding:
 - Each AMT participant’s final rating of the recommendation, including any concerns as appropriate
 - Resources required (personnel, time, costs, and other resources special to Project)
 - Consequences (expected impact or outcome of the action if accomplished)
 - Obstacles (for example: specific conflicts of interest of stakeholders or regulatory requirements or lack of local support that may need to be resolved, or specific lack of resources preventing accomplishment of the action)

The AMT members would have the following responsibilities and commitments.

Responsibilities

- The AMT chair, who will be appointed by the Non-Federal Sponsors, will be responsible for preparing meeting announcements, agendas, and preparing minutes of AMT meetings. Meeting announcements will be required at least 14 calendar days in advance of any meeting, and agendas will be required 7 calendar days prior to the meeting.
- Entity representatives will make every possible effort to attend AMT meetings. In the event that an entity's official representative is unable to participate, the entity or their representative may designate another staff member to serve in that capacity on a substitute basis. If an entity's representative, or designated substitute, does not attend a meeting where a voting matter has been identified in the meeting agenda, votes from that entity will be forfeited.
- The Non-Federal Sponsors are responsible for monitoring and analysis of monitoring data. The Non-Federal Sponsors shall provide individuals with technical expertise, when specific subject-matter expertise is deemed necessary, to present and discuss the analysis of the monitoring data when it is ready for AMT review.
- All entities participating in AMT discussions will be responsible for all costs associated with its participation in AMT meetings and activities.

Commitments

- AMT representatives must be committed to communicate and be willing to share challenges and lessons learned as well as successes
- AMT representatives must strive to create an environment of trust and to foster insightful, non-threatening discussion of ideas and experiences
- AMT representatives must distribute leadership responsibilities and collectively share in the management of the community
- AMT representatives are practitioners, contributing to the community through their experiences, skills, and time
- AMT representatives must agree to be respectful and use appropriate language in group discussions and to listen and respond to each other with open and constructive minds
- AMT representatives must not be afraid to respectfully challenge one another by asking questions
- AMT representatives must openly express their agency's objectives when working to promote them
- AMT representatives must participate to the fullest extent possible
- AMT representatives must commit to search for opportunities for consensus or compromise and for creative solutions
- AMT representatives must contribute to an atmosphere of problem solving rather than stating positions
- AMT representatives must attempt to build on each member's strengths and help each other improve areas in need of further development

AMT recommendations must support the continued operation of the Comprehensive Project to protect the communities in North Dakota and Minnesota from flooding. It is recognized that specific operational considerations may be modified; however, as a fundamental portion of the AMT charter, the ability to operate the Comprehensive Project in accordance with existing permits must and shall be maintained to provide for public health and safety. The AMT will meet within 30 calendar days of the triggers identified in Section 4 of this document and corrective actions will be identified within 30 calendar days of that meeting. This will ensure that actions move forward in a timely manner.

The AMT will also meet within 90 calendar days after every Comprehensive Project operation has been completed to discuss any adjustments needed to the AMMP. For purposes of the AMMP, Comprehensive Project operation means operation by the Authority of the Red River Control Structure or the Wild Rice River Control Structure to restrict flow into the Fargo-Moorhead Metropolitan Area.

1.7. Consideration of the Adaptive Management Team Recommendations by Non-Federal Sponsors and the USACE

As discussed in Section 1.1, adaptive management should not be used if recommendations conflict with permit requirements. It is recognized that adaptive management is a condition of MnDNR Permit No. 2018-0819. Therefore, the AMMP would not be used for implementation of specific permit conditions, including but not limited to permit conditions in the Section 404 Permit, Rivers and Harbors Act of 1899 Sections 9 and 10 Permit, Programmatic Agreement under the National Historic Preservation Act Section 106, U.S. Fish and Wildlife Coordination Act Report compliance, Prime and Unique Farmlands Protection Act Consultation Compliance, North Dakota Sovereign Lands Permit, North Dakota Construction Permits, North Dakota Dewatering Permits, and permits and agreements with local agencies and entities that manage transportation and utilities. With respect to these permit-related decisions, changes would be developed by consultation with the permit agencies and the USACE and Non-Federal Sponsors prior to completion of Project construction and with the Non-Federal Sponsors post-construction.

For all non-permit related decisions, recommendations from the AMT will be considered in a collaborative manner to develop changes in implementation methods, monitoring protocol, performance standards, and, if necessary, objectives and goals. Prior to completion of Project construction, the collaborative process will occur between the AMT, the USACE, and Non-Federal Sponsors. The decision will be made by the Non-Federal Sponsors and the USACE. Post-construction, the collaborative process will continue to occur between the AMT and the Non-Federal Sponsors with the decisions being made by the Non-Federal Sponsors.

2. PROJECT IMPACTS AND MITIGATION NEEDS

The previous NEPA documentation for the Project evaluated potential impacts to a wide range of resource types. The FEIS and the subsequent SEAs from 2013 and 2019 are source documents for this AMMP which set forth the discussion of impact quantification and rationale for impacts warranting mitigation. Project designs were compared with aerial photographs, available data, and in-field observations to estimate the amount, quality, and value of potential habitats impacted by all Project features. The USACE reviewed this information, collaborated with agency partners, and made a final determination on whether or not these losses warranted mitigation. Based on those conversations, the USACE determined to require mitigation for lost aquatic riverine habitat; wetlands; and forests. In addition, MnDNR permit 2018-0819 required that mitigation for fish passage take place at Drayton Dam and that any impacts to geomorphology, fish stranding, and cold weather impacts at the aqueducts also be monitored and mitigated, if necessary.

Since completion of the FEIS, impacts and mitigation needs were updated for several key reasons. Project designs and operations updated from those previously assessed in the FEIS were evaluated in the subsequent SEAs. In addition, collection of additional field data has allowed for a better understanding of both existing habitat quantity and quality. Finally, the North Dakota and Minnesota state permitting processes have included more detailed monitoring and/or mitigation requirements.

USACE policy requires that any potential mitigation planning considers habitat quality as part of the impact determinations. The FEIS estimated habitat quality based on best available information at that time. For example, as described in the FEIS, the quality of floodplain forest impacted was quantified by using a series of USFWS Habitat Evaluation Procedures (HEP) habitat models. These models were used to compute an average habitat suitability index (HSI) score between 0.0 and 1.0 to measure habitat quality. From the qualitative and quantitative determinations, the standard unit of measure, the Habitat Unit (HU), is calculated using the formula: $HSI \text{ score} \times \text{acres impacted} = \text{HUs}$.

Another aspect to assessing lost habitat and mitigation needs is how conditions could change over time within impact areas. Mitigation value could also change over time. For example, floodplain forest mitigation must consider that it takes a considerable amount of time for floodplain forest to grow and mature to full functionality. To characterize habitat changes over time, HUs are calculated for target years and averaged over the life of the Project (50 years) to determine what is known as the Average Annual Habitat Units (AAHUs).

Given the uncertainty with whether habitat conditions might generally improve or degrade in the future, or to what magnitude such changes would occur, the FEIS and subsequent SEAs assumed that conditions would remain constant over time when assessing impacts. It is recognized that habitat conditions likely will not remain constant. However, this approach hopefully minimizes the potential to either underestimate or overestimate potential Project impacts to aquatic and terrestrial habitat. For assessing mitigation benefits, consideration was given as to how long it may take habitat restoration projects to reach full effect.

The above approach was used to estimate habitat quality and mitigation needs for forests and wetland resources. However, habitat mitigation needs will be influenced by available opportunities

and requirements of the North Dakota and Minnesota permits for the Project. The following represents the Project impact and mitigation needs updated through the current design.

2.1. Aquatic Habitat

Impacts have been quantified through collection of pre-project fish and invertebrate data, resulting in Index of Biotic Integrity (IBI) scores. The original plan was to compare IBI scores before and after construction to verify resulting impacts. IBI scores were also to be generated for mitigation sites to help quantify the amount of mitigation created compared to the habitat lost through construction. This approach has been discontinued for two primary reasons. First, this approach is not consistent with the State of Minnesota’s determination of mitigation needs via the MnDNR Dam Safety & Public Waters Work Permit (permit # 2018-0819) for lost aquatic habitat within their state. This will include any post-project monitoring needs. Second, mitigation for lost aquatic habitat in North Dakota will be mitigated via a combination of habitat restoration and fish passage implementation. Because of the challenge of quantifying fish passage benefits and combining them with benefits of site-specific mitigation, these mitigation needs will be met through a mutual agreement with the State of North Dakota. This agreement will be formalized with the State of North Dakota once the design and operation of features along the Comprehensive Project diversion channel near completion and a clearer understanding of mitigation needs can be established.

The IBI scoring system had previously been generated in the Red River Basin back in the 1990s to describe general biotic conditions (EPA 1998). This was used in the FEIS to estimate habitat quality, impacts and mitigation needs. However, the NDDoH subsequently developed both a fish and macroinvertebrate IBI for Red River Basin tributaries (NDDoH 2011a; 2011b). These two IBIs were utilized to calculate IBI scores for all rivers except the Red River. The Red River only utilized a specific fish IBI to calculate habitat quality for sites on this river. The reason is due to limitations with 2017 invertebrate sample collection and the resulting questionable invertebrate data for the Red River. For pre-project data collected to date, the NDDoH provided the IBI scoring results.

Impacts to aquatic habitat were quantified by calculating HUs, with the IBI scores identified above as the habitat quality. The IBIs calculate habitat condition to a score between 0.0 and 1.0, and are then multiplied by the impact area to calculate an amount of habitat lost via impact. This approach noted the potential HUs present within any newly constructed river channels to facilitate routing flow through Project features (e.g., water control structures, aqueducts, etc.).

Aquatic habitat lost through the latest Project designs, and associated proposed mitigation needs, are presented in Table 2.

Table 2. Aquatic habitat footprint impact areas being mitigated and corresponding habitat units for aquatic impacts by Project feature, updated for the most recent design.

Impact	Footprint Area (ac)	IBI Score*	Habitat Units (HUs) Lost
Red River Structure	12.9	0.52	6.7
Wild Rice River Structure	7.8	0.44	3.4
Sheyenne River Aqueduct	8.0	0.54	4.3
Maple River Aqueduct	10.0	0.57	5.7

Impact	Footprint Area (ac)	IBI Score*	Habitat Units (HUs) Lost
Total	38.7		20.1

*IBI scores are an average of fish and invert IBI scores for 2012 and 2017 at the footprint sampling site. The Red River structure uses fish only given some of the challenges with sampling invertebrates on the Red River. Fish IBI scores are also higher than Invertebrate IBI for the Red River, providing a more conservative estimate.

2.2. Floodplain Forest

Some forested areas would need to be cleared for construction of the Project. Forest areas impacted by construction of Project features total 139 acres for the current design. The FEIS outlined a habitat evaluation process for existing floodplain forest in the Project area, which identified a habitat suitability factor of 0.51. This suitability factor is assumed to not have changed as no major changes have occurred in the areas forest composition or structure that would result in appreciable alteration of that suitability factor. Thus, 0.51 is applied to the acres impacted to identify the habitat units for lost forest habitat and the targeted amount for mitigation.

In terms of habitat conditions over the next 50 years, woodland extent, structure, and composition is assumed to remain fairly similar to existing condition. While habitat value for individual species may change over time as natural setback/succession processes occur on these established tracts, the overall habitat value for the riparian woodland community would remain essentially the same and be rated as fair with a HSI of 0.51.

The assumed HSI for an established floodplain forest is 0.51. It is also assumed that it could take a full 50 years for a created forest to reach its full functioning level. Over a 50-year planning horizon (the standard for the USACE planning activities), assuming a starting HSI of 0 and an ending HSI of 0.51, this amounts to an average HSI value of 0.25. Thus, approximately 283.4 acres of floodplain forest habitat would be needed to generate the 70.9 Habitat Units of mitigation needed to offset Project impacts.

Table 3. Estimated floodplain forest mitigation need based on forest habitat lost.

Impact	Footprint Area Lost (ac)		Existing Habitat Quality Score	Habitat Units Lost		Created Forest Habitat Quality Score	Mitigation Needs (ac)	
	ND	MN		ND	MN		ND	MN
Forest	124	15	0.51	63.2	7.7	0.25	252.8	30.6
Total	139		0.51	70.9		0.25	283.4	

2.3. Wetlands

Wetland areas would need to be filled or modified for construction of the Project. This includes areas for the diversion channel, southern embankment, and Oxbow-Hickson-Bakke (OHB) ring levee. The wetland impacts for the diversion channel and OHB are addressed by parallel Section 404 permitting efforts (referenced below). Wetland impacts for the remaining portions of the Project will be assessed through a Section 404(b)(1) analysis and mitigated appropriately. Wetland impacts for the Project are provided in Table 4. Minnesota Routine Assessment Method (MnRAM) wetland

functionality assessment was used to determine mitigation for the Project. It was later decided that MnRAM is not a preferred method in Minnesota so mitigation in that state will follow the ratios in the Minnesota Wetland Conservation Act (WCA). Mitigation would target no net loss of wetland impacts.

Table 4. Estimated wetland impact based on current footprint of the Project.

Wetland Type	Wetland Impacts by Type					
	ND Ditched Wetlands	ND Non-Ditched Wetlands	ND Total Wetlands	MN Ditched Wetlands	MN Non-Ditched Wetlands	MN Total Wetlands
Farmed Seasonally Flooded Basin	0.44	1199.63	1200.07	0.40	15.40	15.80
Shallow Marsh	28.66	51.95	80.61	-	2.99	2.99
Shallow Open Water	-	4.97	4.97	-	-	-
Wet Meadow	73.56	93.06	166.62	16.73	0.83	17.56
Column Total	102.66	1349.61	1452.27	17.13	19.22	36.35
Total	1488.62					

2.4. Geomorphology

Potential effects to waterways, bank stability, erosion, and sedimentation within and outside the existing channel and floodplain (including newly inundated areas) have been discussed at length in the FEIS (geomorphic impacts discussion including Section 5.2) and subsequent SEAs. These impacts and related monitoring are also described in Section 3.3 and Appendix B of the MnDNR Final Environmental Impact Statement (2016 MN EIS), dated May 2016. Potential future conditions impacts were also outlined in geomorphic assessment reports completed by WEST Consultants in 2012, 2019, and 2021. As outlined in the FEIS, the 2016 MN EIS, and the WEST reports in 2012 and 2019, no significant adverse impacts are anticipated. The Project would not likely have a significant effect on stream stability and geomorphology throughout the potentially impacted/affected environment. Multiple features were incorporated to reduce the frequency at which the Project would operate in the future. This was done specifically to minimize potential adverse effects to multiple resource types, including geomorphology. With the updates to the Project operations in the 2019 SEA, no significant adverse effects are anticipated, and no mitigation was proposed. However, geomorphic conditions will be monitored as a part of the AMMP (outlined in Section 4.4). The monitoring plan for geomorphology has been developed, and will be revised over time, as needed, to capture any new concerns. Pre-Project geomorphic monitoring was conducted in 2010/2011, 2018, and 2020. The scopes of work for the pre-Project geomorphic monitoring were developed through a collaborative effort with participating agencies.

2.5. Invasive Species Management

Preventing the spread of invasive species is always a concern during the construction of projects as equipment and materials are transported from other areas. To avoid the spread of invasive species (including Red River and its tributaries that are infested by zebra mussels), contractors will need to prepare an invasive species management plan prior to construction. All equipment that would be in contact with infested waters must be decontaminated prior to entering the water and before leaving the site. Methods for decontamination could include one or more of the following methods: a) Drain and treat all water from equipment; 2) Remove all visible aquatic remnants of plants, seeds, or animals; 3) Remove mud and soil; and/or 4) Hand scrape or power wash with hot water of at least 140° Fahrenheit for at least 10 seconds or use another acceptable treatment method. To avoid the spread of existing invasive vegetative species within the construction boundaries, the plan would delineate existing weed infested areas and include methods to: a) Minimize disturbance; b) Clean equipment before leaving the infested areas; and/or c) Separate stockpile and removed vegetation piles from the infested areas as compared to the non-infested areas. Soil placed in water bodies would not include solid wastes, hazardous materials, or aquatic invasive species.

Construction within Minnesota will require that contractors prevent the spread of invasive species based on MnDNR publication, "Best Practices for preventing the spread of aquatic invasive species;" Minnesota Administrative Rules Chapters 84D and 6216 which address aquatic, terrestrial, and vegetative invasive species; and U.S. Department of Agriculture publication "A guide to Nonnative Invasive Plants Inventoried in the North by Forest Inventory and Analysis" (2017, C. Olson and A. Cholewa).

Construction totally within North Dakota will requires that contractors prevent the spread of invasive species based upon North Dakota Century Codes 4.1-47-02 and 36-26 which address aquatic, terrestrial, and vegetative invasive species; and, within Cass County, additional compliance with *Identification and Control of Invasive and Troublesome Weeds in North Dakota* by North Dakota State University. Within the construction boundaries of the diversion channel construction project, invasive and/or non-native species control would consist of a combination of mowing, burning, disking, and/or mulching or approved use of biocontrol and/or herbicide treatments developed for each invasive or non-native species.

Construction projects that extend into both Minnesota and North Dakota, such as along the Red River, will require compliance with all of the above regulations and guidance.

2.6. Aquatic Connectivity

Previous Project plans and resulting analyses identified potential impacts to biological connectivity and proposed mitigation actions to offset these impacts (2011 FEIS; 2013 SEA). As discussed in the 2019 SEA, Plan B further reduces adverse impacts to connectivity. As outlined within the SEA, the disruption to upstream connectivity in the Red River system would generally be about 10 to 14 days whenever the Project operates, which would only occur for floods with a combined discharge of greater than 21,000 cfs on the Wild Rice River and Red River upstream of the dam (approximately a 20-year event). As stated in the 2019 SEA, "While disruptions to connectivity would still occur with Plan B modifications, it is most likely that these disruptions would be infrequent enough, short

enough in duration, and early enough in the season that broad, measurable, long-term impacts to Red River fish communities would not be expected.”. No additional mitigation in addition to the minimization measures for impacts to connectivity is required by the USACE. Not all resource agencies concurred with this interpretation of impacts.

MnDNR, as a part of its permitting process, is requiring construction of Drayton Dam fish passage. The Project is moving forward as a requirement of MnDNR permit 2018-0819. The permit states that: “The Permittee shall work with DNR on the design of the Drayton Dam Project to ensure that it satisfies the mitigation requirements of this permit.” USACE and the Non-Federal Sponsors have worked continuously with MnDNR over the years to develop Drayton Dam fish passage Project designs. This has recently included a design workshop and several phone conversations and email exchanges to complete Project designs in preparation for a contract advertisement in the near future. The Drayton Dam Project designs have essentially included most, if not all, DNR design requests relevant to fish passage and include the most current design standards that MnDNR uses on its own fish passage projects.

While significant impacts to connectivity were not identified due to construction/operation of the aqueducts on the Maple and Sheyenne Rivers, there is uncertainty around this conclusion. Monitoring activities, including evaluation criteria, are discussed below in Section 4, Monitoring, Performance Standards, and Triggers, to help confirm if the aqueducts are functioning adequately for biological connectivity.

3. PROJECT MITIGATION

The following discussions outline the mitigation approach to meet the mitigation needs identified in Section 2 of this AMMP.

Tables 5 through 8, at the end of this section, provide a summary of mitigation needs, mitigation accomplished to date, and remaining mitigation needs. These tables will be updated over time in subsequent versions of the AMMP and will demonstrate where the USACE and the Non-Federal Sponsors are in relation to meeting their mitigation commitments.

A database for tracking Project mitigation observations and monitoring data is in development. The database will be accessible to the USACE, the Non-Federal Sponsors, AMT, and resource monitoring team members.

3.1. Aquatic Habitat

Mitigation approaches will be developed based upon the location of the resources and the geographical extent of the impacts in Minnesota and North Dakota. MnDNR permit 2018-0819 mandates mitigation to be completed for impacts to aquatic habitat in waters of the State of Minnesota. This includes half of the lost aquatic habitat on the Red River. All remaining lost aquatic habitat (including the remaining half of lost Red River habitat) occurs within the State of North Dakota and is addressed separately.

3.1.1. Aquatic Habitat Mitigation in Minnesota

Restoration of the Lower Otter Tail River (LOTR) has been considered by a number of resource agencies in recent years. The LOTR forms the headwaters of the Red River. Sections of this river, which flows entirely within Minnesota, have been channelized for flood control purposes below Orwell Dam, near Fergus Falls, Minnesota. There is a large extent of habitat that could be considered for restoration, including several meander bends that have been disconnected from the main channel. Restoration measures potentially include reconnecting isolated oxbows, bank stabilization, reconnecting the river to the floodplain, grading, and other features to recreate more natural and stable river habitat. However, constraints to future restoration projects include limitations due to potential increased water surface elevations and landowner participation from properties adjacent to the Project. The USACE and the Buffalo-Red River Watershed District (BRRWD) completed an ecosystem restoration feasibility study for the Lower Otter Tail River in 2022, as authorized by Section 1135 of the USACE Continuing Authorities Program. The design and implementation of measures identified in that study are being pursued.

Per condition 27 of the MnDNR permit 2018-0819 for the Project, “The Permittee shall fund the Lower Otter Tail Restoration Project to a dollar amount that would ensure replacement of all ecological resource values and functions of the public waters impacted by the Project. Ecological resource values will be calculated by the DNR...” The MnDNR determined that \$8.28M would be the appropriate amount of funding to offset aquatic habitat impacts. The Non-Federal Sponsor has executed a memorandum of understanding with the BRRWD and is finalizing a funding transfer

agreement in 2022. Funding received to mitigate impacts of the Comprehensive Project will be implemented separately from funds provided by the USACE Section 1135 project.

3.1.2. Aquatic Habitat Mitigation in North Dakota

In the State of North Dakota, extensive work and collaboration has been done to identify potential river restoration projects to serve as mitigation for Project impacts. This has included meetings and site visits with natural resource agencies, county representatives, watershed coordinators, and other stakeholders. To date, the best candidate projects for aquatic habitat mitigation focus on the Sheyenne River and include components listed below. For additional description on the Sheyenne River mitigation, see Attachment A.

Restoration of the Sheyenne River Oxbow

A meander bend of the Sheyenne River within the Comprehensive Project area has experienced a meander bend cutoff. This cutoff is located between Horace and West Fargo, North Dakota, immediately to the east of Sheyenne Street/Highway 17. The Project under consideration includes reconnecting the isolated oxbow, potentially with additional channel work, grading, and other features to recreate more natural river habitat. The area is relatively small, and a project would need to work within potential constraints of the adjacent highway and residences. The restoration of this meander would not be able to take place until after the Comprehensive Project is operational to avoid potential impacts to water surface elevations. While the amount of mitigation that could be credited here is small, it does provide an opportunity for some direct aquatic habitat mitigation on an impacted water body within North Dakota.

Improve Connectivity in the Sheyenne River

Two existing flood risk management projects near the Fargo metropolitan area have resulted in unfavorable natural resource conditions in the Sheyenne River. The existing Horace to West Fargo Diversion includes a culvert structure that restricts high flow through the natural Sheyenne River channel and diverts flows over a baffle structure into a 7+ mile long diversion channel. The Horace to West Fargo Diversion flows into the West Fargo Diversion. The West Fargo Diversion is a 6.5+ mile diversion channel that operates when gated structures near Interstate 94 and 12th Avenue North are closed to divert water around West Fargo. The structures used to operate the projects inhibit fish passage and decrease connectivity. Restoration would include the removal and modification of existing structures. Removal of the gated structures would substantially improve connectivity throughout the natural channel, while modification of the diversion inlets would also improve passability for fish. The existing projects provide flood risk management and modifications to any of the structures would need to take place after the Project is operational (to ensure that existing flood risk management benefits are sustained) and the Letter of Map Revisions (LOMR) floodplain mapping is complete. Other connectivity improvement projects would consider methods to modify or remove a low-head dam that exists adjacent to a railroad bridge just north of where Main Avenue West crosses the Sheyenne River in West Fargo.

The Sheyenne River Oxbow Restoration is the best candidate for aquatic mitigation in North Dakota. Restoration of the oxbow is in-kind with impacts from the Project, but restoration of the oxbow

alone would not be enough to offset the aquatic impacts in North Dakota. Discussions with the State of North Dakota have indicated that there is strong interest in also pursuing connectivity improvement projects to offset aquatic footprint impacts. Use of connectivity for mitigation of lost habitat is challenging in that it is difficult to quantify exactly “how much” connectivity must be restored to offset a certain loss of habitat. Improving connectivity in the Sheyenne River channel would have clear ecological benefits. A whitepaper on the Sheyenne River restoration measures listed above has been prepared by the USACE and describes the projects in further detail (Attachment A).

The North Dakota resource agencies and the local governments protected by the existing diversion channels have expressed their support of the Sheyenne River channel improvements, with the understanding that implementation would not occur until after the Project is operational and the LOMR process is complete. The State of North Dakota strongly supports these two projects to fulfill the mitigation needs for lost aquatic habitat in the State of North Dakota. The USACE and Non-Federal Sponsors will work with North Dakota agencies to continue Project coordination and document support.

3.2. Forests

Forest impacts and mitigation needs are outlined above in Table 4. The Project results in a need for approximately 70.9 habitat units of mitigation, which equates to 283 acres of newly created floodplain forest.

Work and collaboration to date has resulted in 13 acres (3.3 HUs) of forest mitigation already implemented (Table 8). Construction is currently underway on an additional 72.34 acres (18.1 HUs) of forest mitigation at the former site of the Oxbow Country Club. It is estimated an additional 198 acres (49.5 HUs) will be needed for mitigation. There are many other opportunities for implementing floodplain forest mitigation. The Non-Federal Sponsors have acquired several properties along the Red River and other tributaries that would be suitable for the establishment of floodplain forest. Additional coordination with the resource agencies and Non-Federal Sponsors will occur to prioritize, select, and design specific sites. These sites will be added to Table 8 as the designs become more defined.

In addition to the activities outlined above, forestry mitigation will include, based on agency input, the following actions:

- As outlined in the paragraph above, mitigation will be implemented based on the habitat analysis performed in the original FEIS. Based on this habitat analysis, a 2.1:1 mitigation ratio would be applied for floodplain forest impacts.
- Floodplain lands that are currently in agricultural production or were previously the site of building sites acquired along the rivers will be planted with native tree species. This would include restoring native floodplain forest and herbaceous vegetation. These areas would also provide wildlife habitat. Monitoring will be performed, as outlined in the next section, to verify floodplain forest response is as needed.

- The USACE would develop site restoration plans, including tree planting areas, and clearing, treatment, and management schedules for forest mitigation sites. A combination of direct seeding and seedling trees would be used as needed. Sites would be managed for effective forest growth. Sites may be protected and managed into perpetuity by an agreement for management as a wildlife management area by the MnDNR or NDGF.
- A forest restoration plan will be prepared with input from the Forest Resource Group and will be included as an appendix in a later version of the AMMP.

3.3. Wetlands

Wetland impacts are addressed through US Army USACE of Engineers Permit No. NWO-2013-1723-BIS for the diversion channel and OHB ring levee. Wetland impacts for the Southern Embankment were addressed through the environmental impact analysis in the FEIS and subsequent SEAs and in more detail in this AMMP.

3.3.1. Wetland Impacts Addressed in the US Army Corps of Engineers Permit No. NWO-2013-1723-BIS

Wetland impacts are outlined above in Table 4. Wetland losses due to the diversion channel will be mitigated via wetland replacement that will occur within the constructed diversion channel. These mitigation requirements have been outlined in US Army Corps of Engineers Permit No. NWO-2013-1723-BIS issued to the Non-Federal Sponsors on December 14, 2016, and modified on September 29, 2020. Wetland mitigation for the diversion channel will be addressed through this permit and therefore limited description will be provided in this AMMP.

3.3.2. Wetland Impacts Addressed in the US Army Corps of Engineers Permit No. NWO-2014-0236-BIS

Wetland impacts due to the construction of the OHB ring levee are being mitigated via wetland restoration at the Forest River and Oxbow Country Club sites, as well as the purchase of wetland credits through the Ducks Unlimited In-Lieu Fee Program. Wetland mitigation for the OHB ring levee is addressed in Army Permit No. NWO-2014-0236-BIS and therefore limited description has been provided in this AMMP.

3.3.3. Wetland Impacts from the Southern Embankment and Associated Infrastructure

Wetlands impacted through the construction of the Southern Embankment, which total approximately 261.7 acres, will be mitigated separately from those identified above. Ditched wetland losses will be mitigated with the creation of similar wetlands through the construction of the Project. The remaining wetland mitigation in North Dakota and Minnesota will be accounted for in each of the states separately. Mitigation for the 19.2 acres of non-ditched wetland impacts in Minnesota will be purchased as wetland credits. The remaining non-ditched wetlands in North Dakota that require mitigation total 142 acres and will be mitigated in North Dakota. For a summary of all wetland impacts associated with the Project, see Table 4.

There is a clear difference between the functions provided by the impacted wetlands. Early in Project planning, it was decided amongst the agencies that a function-based approach was

appropriate for determining compensatory mitigation requirements. MnRAM was used for determining compensatory mitigation requirements for impacts. The results of the MnRAM analysis suggested that farmed seasonally flooded areas be mitigated at a 0.88 acres of wetland credits for every 1 acre of impact, while all other wetland types be mitigated at a 1:1 ratio. However, Minnesota WCA rules set minimum replacement ratios that cannot be reduced based on a functional assessment. In addition, there are no state-adopted procedures or policies for using a functional assessment method to determine wetland replacement ratios.

Mitigation for the Southern Embankment wetland impacts in North Dakota would occur in the “Camel Hump” area where the Southern Embankment extends northward between the Diversion Inlet and the Wild Rice River Structure. Hydraulic modeling has indicated that this area will be prone to flooding more frequently after the Project is constructed. This will make the area less desirable for farming and presents an opportunity for wetland restoration along Drain 27. It is anticipated that the Drain 27 Wetland Restoration Project will provide enough wetland credits for the remaining mitigation needs in North Dakota. A contract for the Drain 27 Wetland Restoration Project was awarded in 2022 with construction occurring in 2022 and 2023.

For the nearly 19.2 acres of non-ditched wetland impacts estimated to occur in Minnesota, wetland mitigation credits will be purchased to offset the impacts. The has been collaborating with BWSR to purchase of wetland credits based upon ratios consistent with the Minnesota WCA (1:1 for ag land impacts, 2:1 for non-ag land impacts).

Agency representatives have noted that wetland replacement would incidentally result in wildlife habitat replacement when discussing the potential mitigation needs for wildlife habitat losses.

3.4. Aquatic Connectivity

Previous Project plans and resulting analyses identified potential impacts to biological connectivity and proposed mitigation actions to offset these impacts (2011 FEIS; 2013 SEA). With Plan B the adverse impacts to connectivity have been reduced even further. As stated in the 2019 SEA, “While disruptions to connectivity would still occur with Plan B modifications, it is most likely that these disruptions would be infrequent enough, short enough in duration, and early enough in the season that broad, measurable, long-term impacts to Red River fish communities would not be expected.” No mitigation for aquatic connectivity impacts is required by the USACE.

The MnDNR permit for the Project requires their concerns for biological connectivity be addressed. Per condition 27 of MnDNR permit 2018-0819, “Within five (5) years of permit issuance and no later than the start of construction of the Red River Structure, the Permittee shall have a legally binding commitment to fund the Drayton Dam Mitigation Project, and construction shall have commenced within this same time period. The Drayton Dam Project, which includes the removal of the existing dam and construction of a rock arch rapids, shall serve as partial mitigation for impacts of the Project on the ecology of the Red River, including impacts to connectivity, fish passage, and aquatic resources. The Permittee shall work with DNR on the design of the Drayton Dam Project to ensure that it satisfies the mitigation requirements of this permit.”

Drayton Dam is a low-head dam on the lower Red River at Drayton, North Dakota. It is the last fish barrier on the mainstem Red River within the United States. Several other low-head dams on the Red River have been retrofitted with rock rapids fishways to facilitate fish movement. Drayton is the last location without fish passage. It is also the most downstream dam within the United States that operates as a barrier to the watershed.

Plans and specifications were prepared for fish passage at Drayton Dam with input from the AMT. Fish passage experts, including the MnDNR, were directly involved in developing the design of this Project. A contract for the Drayton Dam Mitigation Project was awarded in 2022 with substantial construction occurring in August 2023.

3.5. Additional Considerations to Minimize Impacts and Mitigation Needs

Coordination with agency members during preparation of the 2019 SEA identified additional considerations to minimize impacts of the Project. The following recommendations will be performed to minimize adverse effects related to the Project:

- To the extent practicable, vegetation clearing activities would be done so as to avoid affecting nesting individuals.
- To the extent practicable, tree clearing on forested land would occur during the winter months in order to avoid impacts to listed bird species during their nesting and rearing periods.
- Wetland mitigation sites constructed for the Project are only anticipated in North Dakota, as wetland credits will be purchased in Minnesota. Wetlands would be managed for invasive species. Invasive and/or non-native plant species would be controlled for three full growing seasons at floodplain forest mitigation sites. Control would consist of mowing, burning, disking, mulching, biocontrol and/or herbicide treatments, as needed. By the third growing season, any planted areas one-half acre in size or larger that have greater than 50 percent areal cover of invasive and/or non-native species would be treated (e.g., herbicide) and/or cleared (e.g., disked) and then replanted with appropriate non-invasive plants. The areal cover percentage was arrived at through discussions with the resource agencies, most recently revisited in March 2020.
- When construction activities are complete, disturbed areas would be seeded with native plant species or other plant species per Project plans and specifications. After native species have been planted, the areas would be monitored and managed to maintain the native vegetation.
- The Non-Federal Sponsors would be responsible for noxious weed control on the whole Project as part of the Operations, Maintenance, Repair, Rehabilitation, and Replacement (OMRR&R).

Impact Tables

Table 5. Aquatic habitat impacts and mitigation.

Aquatic Riverine Habitat Impact	Habitat Lost (HUs)	Mitigation
Red River Control Structure	6.7	Mitigation on the Lower Otter Tail River was directed by the MnDNR as a permit condition for impacts within MN.
Wild Rice River Control Structure	3.4	Mitigation for all aquatic impacts in ND, including shared impacts on the Red River, will be provided through the removal/modification of flood risk management features and restoration on the Sheyenne River. Restoration would not occur until after the Project is operational.
Sheyenne River Aqueduct	4.3	
Maple River Aqueduct	5.7	
Total Aquatic Mitigation Need:	20.1	

Table 6. Forest impacts and mitigation.

Impact	Footprint Area Lost (ac)		Existing Habitat Quality Score	Habitat Units Lost		Created Forest Habitat Quality Score	Mitigation Needs (ac)	
	ND	MN		ND	MN		ND	MN
Forest	124	15	0.51	63.2	7.65	0.25	252.8	30.6

Table 7. Non-ditch wetland impacts and mitigation

Wetland Type	Diversion Channel Wetland Impacts	Mitigation	Southern Embankment Wetland Impacts (acres)	Mitigation
Farmed Seasonally Flooded Basin	1034.39	All wetland impacts associated with the construction of the Diversion Channel will be mitigated by the creation of wetlands within the Diversion Channel itself.	180.64	Mitigation for impacts ND were accounted for via mitigation projects and wetland credit purchases described in Table 8. Wetland mitigation in MN will be met by the purchase of credits.
Shallow Marsh	49.62		5.32	
Shallow Open Water	-		4.97	
Wet Meadow	61.68		32.21	
Total Acres	1,145.68		223.14	

Mitigation Tracking

Table 8. Project Mitigation Tracker

Mitigation Type	Site/Project Name	Site Location	Construction	Acres	Habitat Units	Description
Aquatic Habitat	Lower Otter Tail River Restoration	Breckinridge, MN	TBD	*	*	The MnDNR has determined that \$8.28M will be provided by the Non-Federal Sponsor to fulfil permit condition
	Sheyenne Oxbow Restoration	West Fargo, ND	TBD	2	**	Restoration of oxbow adjacent to Co Rd 17.
	Sheyenne Connectivity	West Fargo/Horace, ND	TBD	TBD	**	Improved connectivity associated with Sheyenne River Flood Control Project
Forest	Red River site	Oxbow, ND	2017	13	3.3	Restoration of ag row crop area with modifications to hydrology.
	Oxbow Country Club	Oxbow, ND	Construction: 2022	72.34	18.1	Restoring wetland of a historic Red River oxbow.
	TBD	TBD	Varies	198	49.5	Floodplain forest areas are being prioritized. Sites will be determined by AMT.
Wetland	Diversion Channel	Fargo, ND	Construction: 2022	TBD	TBD	Amount of mitigation dependent on impacts of final design.
	Oxbow Golf Course	Oxbow, ND	Construction: 2021 Establish veg: 2026	18.8	12.26	Restoring wetland features for an old Red River oxbow. Includes: 10.62 acres of wet meadow/shallow marsh; 8.18 acres of upland buffer

Mitigation Type	Site/Project Name	Site Location	Construction	Acres	Habitat Units	Description
	Forest River	Briarwood, ND	Complete	6	6	Restoration of wetlands near Briarwood, ND
	DU In-Lieu Fee Credits	NA	NA	NA	17.27	Purchased for work on OHB
	Drain 27 Wetland Restoration	Stanley Township, ND	Construction: 2022 Establish veg: 2027	320	169.8	Mitigation for wetland impacts for the Southern Embankment and Associated Infrastructure in ND
	MN Wetland Bank Credits	NA	NA	NA	23.03	The purchase of wetland credits may occur at several iterations. The first purchase of 0.5 credits is anticipated in August of 2021.
Connectivity	Drayton Dam Modification	Drayton, ND	Construction: 2022/2023	*	*	Mitigation to fulfil MnDNR permit condition

*The MnDNR prescribed this mitigation as a permit condition.

**Mitigation amount needed for impacts within North Dakota will be developed through the AMMP with North Dakota and the USACE/Sponsors. This agreement will be formalized with correspondence.

4. MONITORING, PERFORMANCE STANDARDS, and TRIGGERS

Monitoring methodologies, performance standards, and adaptive management triggers will be used to better characterize pre-project conditions for key resources, identify changes following Comprehensive Project implementation, verify resulting Comprehensive Project impacts, and verify whether mitigation is offsetting these Comprehensive Project impacts.

Monitoring and adaptive management of resources impacted by the Comprehensive Project and mitigation projects is the responsibility of the Non-Federal Sponsors.

Monitoring

Monitoring helps capture the state of a resource at a particular point in time and can help to track changes that a resource experiences. Monitoring methodology and frequency have been collaboratively established with input from natural resource agencies.

Monitoring activities will be focused on key resources of concern. These include:

- Connectivity Mitigation for Aquatic Habitat (mitigation)
- Floodplain Forest (mitigation)
- Wetlands (mitigation)
- Aqueduct Connectivity (resource of concern)
- Geomorphic (resource of concern)
- Water Quality (resource of concern)
- Fish Stranding (resource of concern)

Monitoring for aquatic habitat, floodplain forest, and wetlands is associated with impacts warranting mitigation. Geomorphic and water quality impacts were not deemed to be significant and therefore no mitigation was required. Geomorphology and water quality have been or will be further monitored prior to and after construction or Comprehensive Project features to verify these assumptions. Similarly, fish stranding following Project operations was not considered as a significant impact but will be monitored, with potential mitigation needs pending results.

Monitoring plans were developed for each resource based on the information available at the time this AMMP version was written. The monitoring approaches outlined below will need to remain flexible to adapt to changing conditions (either pre- or post-project); alternative technologies or techniques that become available for monitoring; and refinement of specific Project features or mitigation actions. Revisions to monitoring plans would require AMT approval. In addition, many of the monitoring schedules may overlap with each other. Where this occurs, it is highly recommended that the resource agencies attempt to coordinate field surveys concurrently so that data can be compared and utilized efficiently.

Pre-construction monitoring efforts are led by the USACE and the Non-Federal Sponsors. In 2023, monitoring and adaptive management would be the responsibility of the Non-Federal Sponsors except for pre-construction monitoring efforts for the Sheyenne River Mitigation Project. Monitoring results will be shared with the AMT when the data is processed and ready for distribution.

Performance Standards

Performance standards are measurable criteria set to help determine the success of mitigation efforts. Where specified, monitoring can be concluded once performance standards are met. If performance standards are not met within a defined amount of time, adaptive management of that resource or alternative mitigation options may be necessary.

USACE regulations require that projects develop and use criteria for determining ecological success of mitigation and to ensure Comprehensive Project impacts are offset. The metrics used to measure impacts and mitigation effectiveness are described below. Even with the use of metrics, it is recognized that conclusions on Project impacts and mitigation success will need to include detailed review of data and collaboration amongst the AMT. Even then, opinions may differ on the questions at hand. However, the discussion below provides guidance on the metrics that will be used to verify Comprehensive Project impacts and mitigation effectiveness. These metrics will provide the primary measure of whether or not mitigation has proven effective.

Triggers

Triggers are predetermined values that serve as thresholds for specific actions or further evaluation of a resource. Triggers fall into one of two categories: 1) monitoring triggers or 2) adaptive management triggers.

Monitoring triggers are events that cause additional monitoring to occur. For the Comprehensive Project, several monitoring triggers have been identified in particular resource areas for significant flood events. Pre-project monitoring triggers will help to expand the baseline data so there is a better understanding of existing flood impacts which are more suitable for comparison after Comprehensive Project operation. After Comprehensive Project construction, monitoring triggers will provide data that can help to assess the actual impacts of the Comprehensive Project. Resource areas with monitoring triggers are identified in the text below.

Adaptive management triggers are measurable changes to a resource that leads to a defined response or further evaluation. Evaluation will consider monitoring data and any additional underlying circumstances that could have influenced the triggers to be met. The result of evaluation may lead to modification of a particular feature, changes in the management of a resource, or even no action if it is determined that changes were the result of something other than the Project. Adaptive management triggers for the Comprehensive Project can be found in the resource area descriptions in the text below.

4.1. Aquatic Habitat and Connectivity

Mitigation needs for lost aquatic habitat in waters of Minnesota have been directed by MnDNR via their permit. In a letter dated May 19, 2021, the MnDNR indicated that funding of \$8.28M toward restoration of the Lower Otter Tail River was the appropriate amount of mitigation necessary to offset aquatic impacts in Minnesota. In the same letter, the MnDNR also determined that monitoring will not be required on the Lower Otter Tail River.

Mitigation needs for lost aquatic habitat in waters of North Dakota will be accomplished via a set of projects on the Sheyenne River. This includes restoration of a Sheyenne River oxbow and improvements in biotic connectivity via modification to the Sheyenne River Flood Control Project, as well as a small dam in West Fargo. As outlined above, the State of North Dakota has agreed that this is adequate mitigation for aquatic habitat losses in their state. However, to confirm these projects are effectively working, monitoring activities will be performed. These monitoring activities will be done in concert with evaluation of whether fish are able to effectively move across the Sheyenne River aqueduct which is immediately upstream of the Sheyenne River connectivity mitigation project. The exact monitoring activities are still under discussion, and may include a combination of netting, hydroacoustic observations, radio telemetry, and other techniques. The specifics will be added to this subsection once identified and approved by the AMT.

The following discussion on the Sheyenne River Mitigation Project will include an overview for evaluation of connectivity through the Sheyenne River and Maple River aqueducts. These are similar discussions, with Sheyenne aqueduct performance critical to the effectiveness of the Sheyenne River Mitigation Project.

Performance Standards and Metrics

Red River Structure Monitoring Activities

The Non-Federal Sponsors will observe average cross section velocities through the Red River Structure at discharges close to 2,900 cfs, 8,100 cfs, and 10,700 cfs, which are equal to the 50%, 10%, and 5% annual exceedance probability flows, respectively, through the Red River Structure, as reported in the 2019 SEA. A reasonable surrogate for determining Red River Structure discharges prior to operations is the USGS gage on the Red River at Hickson, ND. This is to verify velocities that generally align with those identified in the 2019 SEA (approximately 2 fps at a discharge of 10,700 cfs). These results will be coordinated and discussed with the Biotic Resource Management Team and the AMT to determine if any additional actions are warranted. Given the general consistency of results from both computer modeling and physical modeling for the Red River Structure, it is unlikely that actual velocities will differ substantially from those predicted.

Minnesota Mitigation

Standards and metrics associated with aquatic habitat for impacts and mitigation in Minnesota will be done in accordance with the MnDNR and associated Project permit. This includes restoration on the Lower Otter Tail River and will include direct collaboration on design with the MnDNR. Because these actions will ensure that impacts are offset, no monitoring is proposed at this time for this aquatic habitat mitigation.

North Dakota Mitigation

Sheyenne River Mitigation and Aqueduct Connectivity Evaluation Methodology

Habitat benefits of the Sheyenne Mitigation Project will be evaluated to confirm an acceptable level of improvement for offsetting lost aquatic habitat in North Dakota due to the Project. This will be

done in concert with an evaluation of connectivity through the Maple River and Sheyenne River aqueducts also to be constructed as a part of the Project.

Participation and Timing

The evaluation will be performed by the Project Non-Federal Sponsors as a part of the AMMP and the Project's O&M requirement. Resource agencies (i.e., NDGF, MnDNR, and USFWS) will be invited and involved with this process to the full extent they are willing/able to do so. Note that the precise timing of an evaluation will be dependent on completion of construction. At this time, the aqueducts would not be completed and functioning until 2025. Sheyenne River Mitigation will not be constructed until the entire Project is operational and the LOMR process is complete. Given this timing, and the fact that an evaluation of both the mitigation and aqueduct will likely be strongly related, full evaluation may not occur for seven to eight years, or more. With likely improvements in science and technology to track and observe fish in turbid environments, the proposed methodology here can and should be revisited as the timing for evaluation draws closer. The following is intended to provide an overview of an evaluation process and a commitment by Non-Federal Sponsors to evaluate the effectiveness of the mitigation project and confirm whether or not the aqueducts are effectively passing fish. Note that designs are not currently available for any of these features, which is part of the reason why the following methods are proposed and not finalized.

Goals and Objectives of Mitigation

Goal 1: Improve connectivity on the lower Sheyenne River

Objective 1.1: Remove instream structural features to restore in-channel connectivity

Objective 1.2: Improve connectivity through diversion channels through installation of nature-like fishways across upstream control weirs

Key Questions to Answer:

- Are resulting hydraulics at rock rapids similar to what was designed?
- Do fish enter the Sheyenne aqueduct bypass channels, especially with the rest of the channel open?
- Do fish reach the rock rapids?
- Do fish successfully pass the rock rapids?
- Do fish pass the concrete weir adjacent to the railroad bridge north of Main Avenue West in West Fargo?
- Do IBI metrics in project area improve with improved connectivity?

Performance Standards to Measure Success

- Where instream structures are removed, return the channel to the same dimensions and channel substrates as adjacent areas upstream and downstream.
- Rock rapids fishways in bypass channels that would be implemented for the Sheyenne River Mitigation Project will employ the latest design standards for rock ramp fishways.

Successfully meeting this standard means maintaining the following design criteria. This will be done to the fullest extent allowed by site hydraulics. This includes:

- <3% slope down centerline of fishway
 - <0.7ft drop between individual rock boulder weirs
 - Use of alternating sine wave weirs
 - Boulder pools between weirs of at least 3ft of depth
 - Pool widths should be at least 30ft between the widest points of alternating sine waves
 - No smooth sills should extend above adjacent rock at the crest maintain upstream water elevations
- If a rock rapids fishway is used at the weir near the Main Avenue West railroad bridge, achieve and maintain the exact same design criteria as those outlined above for rock ramp fishways in the bypass channels.

Monitoring Activities

Methods discussed here are preliminary and need to be developed further based on what the final design of the mitigation project will be. Effort also will be made to incorporate evaluation of connectivity across the Sheyenne River aqueduct with evaluation of Sheyenne River mitigation effectiveness. Potential integration of those two efforts is discussed later.

Pre-Project

Fish Collection. Anecdotal observations have noted fish presence in the Sheyenne River Flood Control Project diversion channels. If practicable, perform cursory monitoring to confirm fish use of the diversion channels and presence below existing weirs on the West Fargo Diversion, and Horace to West Fargo Diversion. This will include notes for species diversity and size. Sampling should occur in or near the weir tailrace during springs when the diversion channels have been conveying water. Sampling could include seining or electroshocking. Sampling should occur bi-weekly during the period April through June during at least one event prior to Project construction.

IBI Methodology. An evaluation of river health via IBI methodology has already been performed pre-project with observations from 2012 to 2017. This included measurements of both fish and macroinvertebrate IBI. Observations were made at several points on the lower Sheyenne River, including areas relatively close to the proposed oxbow restoration. At this time, no further pre-project data is recommended.

Post Project

These future studies are described generally; detailed experimental designs will be developed in consultation with agency partners during preparation of plans and specifications for project implementation. The monitoring noted would most likely be a part of a broader evaluation of connectivity across the Sheyenne River aqueduct. As these designs are not yet available, and construction is several years away for Sheyenne River fish passage mitigation, a revised study plan will be developed. It is likely that technology improvements in the technique outlined would want to be captured with the final study design.

- **Field Survey of Fish Passage Structures.** For any rock ramp fishway, perform surveys every five years post-construction to ensure the above design criteria performance standards are maintained. These structures are within the area of protection and should not experience flows above a 2-year flood event. As such, post flood surveys should not be needed.
- **Passive Adaptive Management Monitoring: IBI Methodology.** Utilize the Index of Biotic Integrity protocol (fish and macroinvertebrate) to survey locations on the Sheyenne River. Protocol for use will be that used previously in 2012 and 2017 with the IBI assessment for the Sheyenne and other rivers of concern in the Project area. Locations will be the same as those surveyed in 2012 and 2017. This should include a minimum of two sampling events after the Sheyenne River fish passage mitigation project has been completed. This should likely happen at least two years following completion of the Sheyenne River mitigation project. Results will help reflect on the effectiveness of fish passage of both the mitigation project, as well as the aqueducts, on improving river health in the area.
- **Passive Adaptive Management Monitoring: Fish Capture.** Fish capture sampling in the tailwater of at least one of the bypass channel rock rapids fishways will provide information on the species composition and size structure of fish below the fishway. Fish passing through the fishway will also be monitored with capture nets placed at the upstream exit of the rock rapids fishway. Results will not be compared to any specific performance targets and will be made as a cursory evaluation of fish occurrence and use around the structure. Sampling should occur bi-weekly during the period of April through June during at least one seasonal period post-project construction. Final methods will be developed closer to Project implementation.

Goal 2: Restore Sheyenne River aquatic habitat via oxbow restoration

Objective 2.1: Return flow through identified historic oxbow and return the channel to likely dimensions pre-disturbance, maintaining long-term stability

Key Questions to Answer:

- Is oxbow functioning as natural channel?

Performance Standards to Measure Success

- Return flow to the historic channel and maintain channel stability.

Monitoring Activities

Post Project

- **Geomorphology.** Utilize geomorphic assessments, using the protocol outlined in the Geomorphic Monitoring Plan (Attachment B), to confirm that the channel is stable and functioning as a natural channel. This should include a minimum of two sampling events after the oxbow restoration project has been completed. This methodology can be revised in the future if simpler methods would be adequate to confirm channel stability.

Aqueduct Evaluation and Associated Triggers

Biological connectivity through the Project aqueducts is important for river health and function. Connectivity through the Sheyenne River aqueduct is especially critical to work in concert with the Sheyenne River connectivity mitigation project. Following is the evaluation approach for aqueduct connectivity.

Goals and Objectives of Aqueduct Design

Goal: Maintain connectivity on the lower Sheyenne and Maple Rivers through the planned Project features

Objective: Maintain the ability for the full range of species and size diversity to move through the aqueducts at a level similar to existing conditions

Key Questions to Answer:

- Are resulting hydraulics in the aqueducts adequate to allow fish passage?
 - Are velocities generally adequate to allow fish passage across the majority of flow conditions?
 - Are roughness elements incorporated adequate to promote velocities pattern that promote effective fish movement?
- Do fish of all species and sizes enter the aqueduct?
- Do most fish that enter the aqueduct exit the upper end of the aqueduct?

Triggers to Measure Impact Levels

The following criteria are in draft and will need refinement. Criteria need to be appropriately developed in-line with the capabilities of available methods and technologies. In particular, the ability to make biological measurements makes similar criteria difficult to employ.

The USACE and the Non-Federal Sponsors will coordinate during the development of the design concept for the aqueducts to maintain connectivity. This will likely include some form of the following:

- Fish that arrive at the downstream end of the aqueduct are able to successfully pass for flows up to the 50 percent annual flow event.
- Maintain water velocities conducive to biological connectivity up to project operation.
- Incorporate roughness elements in the aqueduct of similar design/pattern as that outlined in the USACE/Non-Federal Sponsors physical flume study of the Maple River aqueduct.

Monitoring Activities

At this time, the aqueduct design concepts have not been fully developed. The Sheyenne River and Maple River aqueducts across the diversion channel will be designed to convey winter flows through the aqueducts and control ice formation to prevent ice from impeding the hydraulic capacity or performance of the system and to resist ice and debris without damaging, reducing capacity, or

reducing function of the aqueducts (October through April). At each aqueduct, flows will be measured to determine the flows upstream of the spillway into the diversion channel, flows entering the aqueduct, and flows exiting the aqueduct.

The most specific methods for monitoring fisheries conditions in the aqueduct will be developed with agency input as aqueduct designs progress. Some methods that are being considered include the use of an acoustic doppler current profiler (ADCP), fish collection, hydroacoustic monitoring systems (e.g., DIDSON or ARIS camera), Passive Integrated Transponder (PIT) tagging, and acoustic tagging.

Mitigation Contingency

Should monitoring suggest that Sheyenne River mitigation or either aqueduct performance is not meeting the mitigation Performance Standards, or triggers are met, the Non-Federal Sponsors will meet with natural resource agencies to discuss whether modifications to Project features are possible, or if additional mitigation is needed to further offset Project impacts.

- Features such as rock rapids at the existing Sheyenne River diversions channels could be relatively easy to modify. If field surveys reveal fish passage features fall out of the design criteria, the Non-Federal Sponsors will modify Sheyenne fish passage structures to meet design criteria.
- If the Sheyenne oxbow channel restoration is no longer stable, the Non-Federal Sponsors will meet with the resource agencies to consider on-site modifications to improve channel stability and on-site habitat conditions.
- Final determinations on acceptability of the effectiveness of the Sheyenne River mitigation project, and whether any there are any additional mitigation needs, would ultimately fall to agreement between NDGF and the Non-Federal Sponsors. All resource agencies would be able to provide input on that decision.
- Modifications to the aqueducts could be much more difficult if performance triggers are not met. If this occurs, the Non-Federal Sponsors will meet with the natural resource agencies to discuss potential options to address the issue. This could include modifications such as addition or alteration of the roughness elements. It could also include additional mitigation actions to improve fish passage elsewhere on the Sheyenne River. The scope and scale of potential actions due to aqueduct triggers is much more difficult to project and will have to be dealt with as it arises.

4.2. Floodplain Forest Habitat

The majority of baseline data needed to quantify existing habitat value of floodplain forest impact areas has been collected (please see Appendix F of 2011 FEIS). No additional floodplain forest surveys are planned prior to construction. Following construction, monitoring will be performed to determine the condition of these habitat types and the overall effectiveness of their mitigation.

Vegetation will be monitored annually for the first five years following planting using stratified random sampling. At each randomly generated point within the areas planted, plots of 0.01 acre will be surveyed according to USACE standard forest inventory procedures. An average of at least one plot per acre will be surveyed. Tree survival and composition will be monitored every ten years.

The goal of the floodplain forest habitat is to provide the area and quantity needed to offset the loss of forest habitat through footprint impacts. The following performance standards will be used to measure when forest mitigation has reached full effectiveness. The metric will be the habitat unit adjusted for quality over time against when the standards below are met.

Forest Performance Standards:

- Restore native floodplain forest and herbaceous vegetation. The floodplain forest should include green ash, cottonwood, black willow, hackberry, quaking aspen, American elm, American basswood, and bur oak.
- Restore stand density with an average of 300 trees per acre over 80 percent of the mitigation site(s) with diameter at breast height (DBH) of 2 inches within 10 years if using seedling plantings, direct seeding, or natural seeding. This tree density is typical for the Red River Basin floodplain forest in the Project vicinity. If using container trees, an average of 90 trees per acre over 80 percent of the mitigation site(s) with diameter at breast height (DBH) of 4 inches within 10 years.
- Restore floodplain forest community with a target species composition of at least 10 percent by number of individual trees to be bur oak and hackberry, with the rest a mix of green ash, cottonwood, black willow, boxelder, American elm, and American basswood.
- Allow some regeneration of native herbaceous plants, shrubs, and trees from locally produced propagules on 20 percent of the mitigation land area, to create diversity in forest and herbaceous vegetation in the mitigation area.
- Protect and manage the site(s) in perpetuity.

Trees will be replanted as needed to meet the target vegetation cover. Invasive, noxious and/or non-native species will be controlled for three full growing seasons. Control will consist of mowing, burning, disking, mulching, biocontrol and/or herbicide treatments, as needed. By the third growing season, any planted areas one-quarter acre in size or larger that have greater than 50 percent areal cover of invasive and/or non-native species will be treated (e.g., herbicide) and/or cleared (e.g., disked) and then replanted with trees.

The monitoring results will be compiled, interpreted, and described in letter reports. The monitoring reports will be provided to the AMT. The AMT will decide if additional forest monitoring is needed at the conclusion of the five-year monitoring period for floodplain forest.

The monitoring approach identified above is targeted for establishing new forests. Sites would be monitored for tree survival annually for five years, then tree survival and composition at ten years. Tree survival and composition would be monitored every five years thereafter until it can be demonstrated that value of the forest habitat lost has been replaced through mitigation. As the forest sites age, monitoring beyond the first five years, if recommended by the AMT, may be adjusted to evaluate mature forests. At that point, forestry monitoring may be performed using the

USACE St. Paul District's Forest Inventory Phase II Protocol (available upon request), adapted as needed for monitoring in the Project area. The Non-Federal Sponsors would be responsible for providing this justification and receiving approval from the AMT.

Adaptive management would be used to manage the mitigation sites. Monitoring would include measurement of the performance standards and the implementation of corrective actions would be carried out if the standards were not being met.

4.3. Wetland Habitats

A wetland delineation has been conducted along the alignments for the diversion channel and Plan B Southern Embankment. A MnRAM functionality assessment had been performed to determine mitigation needs in North Dakota. This information was used to verify the mitigation approach for these wetlands. Surveys of the diversion channel will be performed after construction to verify that the wetland type and function present are offsetting wetland areas lost through construction.

Post-construction monitoring shall be conducted annually to determine the type, quality, and amount of wetlands created as compensatory mitigation for the unavoidable impacts. The purpose of the monitoring is to provide information to determine if the site is successful in meeting its performance standards. The monitoring period for wetlands shall be five years. This period may be shortened if the monitoring reports demonstrate that the mitigation site(s) has met vegetation and hydrology performance standard(s) in two consecutive reports and the AMT concurs that additional monitoring is not required.

Monitoring reports shall be concise and effectively provide the information necessary to assess the status of the compensatory mitigation project. Monitoring shall commence the first full growing season after completion of construction (construction includes earth moving, excavation, and other physical work as well as planting and seeding), approximately May 1. Best Management Practices will be employed between planting and the start of monitoring. Annual monitoring reports shall be submitted on or before December 31 for each of the required monitoring years and will be provided to the AMT.

Monitoring reports shall contain the following information and any additional information necessary to evaluate the performance of the mitigation site:

- Name of party responsible for conducting the monitoring and the date(s) the inspection was conducted;
- A brief paragraph describing the mitigation acreage and type of aquatic resources authorized to compensate for the aquatic impacts;
- Written description of the location of the compensatory mitigation project including information to locate the site perimeter(s) and coordinates of the mitigation site (expressed as latitude, longitudes, UTM's, state plane coordinate system, etc.);
- Dates the compensatory mitigation project commenced and/or was completed;
- Short statement on whether the performance standards are being met;
- Summary data, including photo documentation, to substantiate the success and/or potential challenges associated with the compensatory mitigation project;

- All plant species along with their percent cover, identified by meandering through each vegetative community, including upland buffers, and list commonly encountered, or dominant and co-dominant, species observed. In addition, the presence, location, and percent areal cover of invasive, noxious and/or non-native species in any of plant communities will be noted
 - Vegetation cover maps at an appropriate scale will be submitted for each reported growing season
 - Photographs showing all representative areas of the mitigation site taken at least once each reported growing season during the period of July 1 to September 30. Photographs will be taken from a height of approximately five to six feet from at least one location per acre. Photos will be taken from the same reference point and direction of view each reporting year. Location of the photographs should be mapped on a GPS unit
 - Surface water and groundwater elevations in representative areas. The location of each monitoring site will be shown on a plan view of the site
 - Precipitation data to address the 50 percent chance or "normal growing season." Can use the following website: <http://agacis.rcc-acis.org/>
- Maps showing the location of the compensatory mitigation site relative to other landscape features, habitat types, locations of photographic reference points, transects, sampling data points, monitoring well locations, and/or other features pertinent to the mitigation plan;
 - A summary of the amounts and type of wetlands restored, enhanced, and created at the mitigation site identified by wetland plant community types based on Wetland Plants and Plant Communities of Minnesota and Wisconsin (Eggers and Reed);
 - Dates of any recent corrective or maintenance activities conducted since the previous report submission;
 - Specific recommendations for any additional corrective or remedial actions; and
 - If non-compliance activities are occurring on the site, the activity will be noted, photographed, and mapped on a GPS unit. Best professional judgment would be used to determine if the activity is not compliance with easement or mitigation site plan.

The final monitoring report shall also include a wetland delineation completed in accordance with the *Regional Supplement to the USACE of Engineers Wetland Delineation Manual: Great Plains Region*.

Over two-thirds of the wetlands that are impacted are seasonally flooded wetlands or farmed wetlands; these wetlands have very poor function. It is not environmentally preferable to compensate for impacts to degraded wetlands by deliberately providing degraded compensatory mitigation projects. A compensation project should result in high quality wetlands that provide optimum functions within its landscape context, taking into account unavoidable constraints. Even though the wetlands impacted by the Project are generally highly degraded, they should be mitigated for by restoring equal acres of wetland or by restoring functions that are lacking in the Red River Basin watershed. Wetland mitigation in North Dakota will be evaluated with a functional assessment tool (MnRAM) to factor in wetland quality and functional value and ensure that mitigation is adequate.

In addition to the monitoring activities outlined above, wetland monitoring will include, based on agency input, the following actions:

- Adaptive management would be used to monitor any project-specific mitigation sites. Monitoring would include measurement of performance standards and the implementation of corrective action measures if the standards were not being met.
- The MnRAM wetland assessment method or other agreed upon methods would be used to assess the adequacy with which the mitigations replaced lost wetland function.

The goal of the wetland mitigation is to the area and functional value to offset the loss of such habitat through footprint impacts. It is anticipated that all wetland impacts in Minnesota will be mitigated through the purchase of wetland banking credits and therefore performance standards for those banks have already met those established by BWSR and the Minnesota WCA. The following performance standards were developed in coordination with North Dakota natural resource agencies and will be used to measure when wetland mitigation has reached the appropriate functional value. The metric will be the acre meeting functional value as measured by MnRAM.

Wetland Performance Standards:

Definitions:

InNN: invasive and/or non-native plant species

NNI: native, non-invasive plant species

Relative areal cover: the proportion (percentage) of the total absolute areal cover by an individual plant species, or group of plant species (e.g., hydrophytes), within a reference area or plot; sum of all proportions equals 100 percent

Wet Meadow/Wet Prairie

Fresh (wet) meadows, sedge meadows, wet prairies, and seasonally flooded plant communities (Type 1 and Type 2 wetlands) will be monitored separately and shall each achieve a species composition that includes 10 or more species of native/non-invasive grasses, sedges, ferns, rushes and/or forbs by the end of year 5. Relative areal cover of native, non-invasive species (NNI) versus invasive, non-native species (InNN) of $\geq 60\%$ NNI and relative areal cover by hydrophytes of $\geq 70\%$. Alternatively, a MnRAM vegetative diversity and integrity score of "high quality" by the end of year 5 would also satisfy this performance standard.

Marsh

Shallow and deep marsh plant community types shall be combined. Marsh plant community types with a species composition that includes 6 or more native OBL hydrophytes and any floating or submergent species by the end of the 5th full growing season. The threshold for relative areal cover NNI versus InNN should be 50 percent. A MnRAM vegetative diversity

and integrity score of “high quality” for each these plant communities will also satisfy this performance standard.

Upland Buffer

Restored tallgrass prairie in the upland buffer with a species composition that includes 15 or more species of native non-invasive grasses, sedges, rushes, forbs and/or ferns, with approximately 80 percent or greater areal coverage of the total buffer area having NNI species by the end of year 5.

Hydrophytes

Relative areal cover by hydrophytes shall be more than 50 percent within the wetland communities of the mitigation site.

Invasive Species

Invasive and/or non-native plant species will be controlled within each wetland mitigation site. Control could include mowing, burning, disking, mulching, biocontrol and/or herbicide treatments. By the third growing season, any areas one-quarter acre in size or larger that have greater than 50 percent areal cover of invasive and/or non-native species would be treated (e.g., herbicide) and/or cleared (e.g., disked) and then reseeded. Follow-up control of invasive and/or non-native species shall be implemented as stated above.

Hydrology Performance Standards:

The minimum wetland hydrologic criteria for wetland hydrology are 14 or more consecutive days of inundation or saturation during the growing season with a 50 percent chance (or more) annual probability of occurrence.

- Hydrology will be measured within each wetland type.
- The number of monitoring wells and/or staff gauges necessary for monitoring the hydrology of a compensation site varies with size and complexity of the site. For the Drain 27 mitigation site, staff gauges will be installed between elevations 899 – 901 at four different locations. Shallow groundwater monitoring wells will be installed at elevations 906.5 and 908 at three separate transect locations.
- The frequency of water level readings must be sufficient to determine whether performance standards are met.
- Duration of monitoring hydrology at compensation sites is generally two growing seasons but can be increased or decreased due to site-specific conditions and goals/objectives.
- Monitoring wells should be installed and data collection begun as soon as frost is out of the ground. If this is not feasible, monitoring wells should be installed, and data collection begun as early in the growing season as possible. The “growing season” for a particular monitoring year is determined in accordance with the Regional Supplement to the USACE of Engineers Wetland Delineation Manual: Great Plains Region.
- Staff gauges with cameras can be used to record water level readings.

4.4. Geomorphic

The Red River and tributaries are dynamic river systems that naturally show movement of their mobile boundaries. The Geomorphic Monitoring Team (GMT) collaboratively developed comprehensive Geomorphic Monitoring Plan (GMP), which is included as Attachment B to this AMMP. The bullet points below present a brief summary of the GMP. Because this AMMP contains only a summary of the GMP, in the event the language in the GMP and this AMMP are in conflict, the GMP shall govern, unless otherwise agreed to by the AMT.

- Purpose: Ensure the Project does not result in detrimental geomorphic impacts relative to the pre-project dynamics of the system and the reference reaches and if such impacts occur to implement beneficial mitigation measures.
- Goal: Monitor streams in the Project area vicinity for geomorphic changes and, if geomorphic changes are deemed by the GMT to have been caused by the Project, to identify Project operation adjustments and/or mitigation measures to meet established GMT and Project goals.
- Geomorphic Assessment Locations and Methods (future efforts can be adjusted as appropriate by the GMT and AMT):
 - Monitor 39 Geomorphic Monitoring Stations (GMSs) pre-Project (with locations shown in Figure 2) and at least 247 GMSs post-Project cross-sections.
 - Collect cross-sectional data at long-term monitoring cross sections. Cross-section data collection would include top-of-bank, bankfull, and water surface elevations along a straight line of site trajectory between monuments and along a hydraulic modeling trajectory (model reaches).
 - Collect longitudinal profiles to collect bed topography data in the down-channel direction within the extents of each GMS.
 - Leverage bathymetry with/from other sampling efforts in the Project vicinity when available to assess channel bed conditions especially outside the monitoring stations.
 - The USACE is working with WEST to evaluate video footage methods to document unstable banks, erosion, deposition, and other changes that could occur due to the Project or other items. The study will consider technical and economic factors related to the use of drone-mounted LiDAR, multiple cameras mounted on boats, multi-beam sonar (especially along the Red River), and other methods. Following the study, the results shall be presented to the AMT for further consideration to improve data collection.
 - Collect both instream and bed and bank sediment samples only if significant changes are apparent with respect to the historical data.
 - Complete Rosgen Level II assessments while also collecting data for select Rosgen Level III worksheets as the standard Level III assessment is not entirely applicable to the Red River. Assessments should be completed by practitioners with at least ten years of experience in riverine geomorphic measurements and analysis.

- Conduct specific gage analysis for all USGS gages in the Project vicinity.
- Evaluate changes in surveyed cross section geometry.
- Evaluate changes in surveyed longitudinal profile.
- Evaluate bank movement, sinuosity, channel (meander) migration and erosion rates, and meander amplitude and frequency using aerial photography. Aerial imagery has been historically collected every few years and used to capture trends in the land surface, including use and observations of impacts from the Project and other causes. During construction and post-construction, the intervals should be conducted to occur before scheduled geomorphological field assessments (scheduled every 5 years) to inform the assessment scope of work. The aerial surveys could continue to be conducted more frequently as determined by the local agencies which use the aerial information for other purposes.
- Evaluate trends in sedimentary features (in-stream sediment bars), changes in large woody debris (LWD), and changes in riparian vegetation type.
- Evaluate the degree of channel incision.

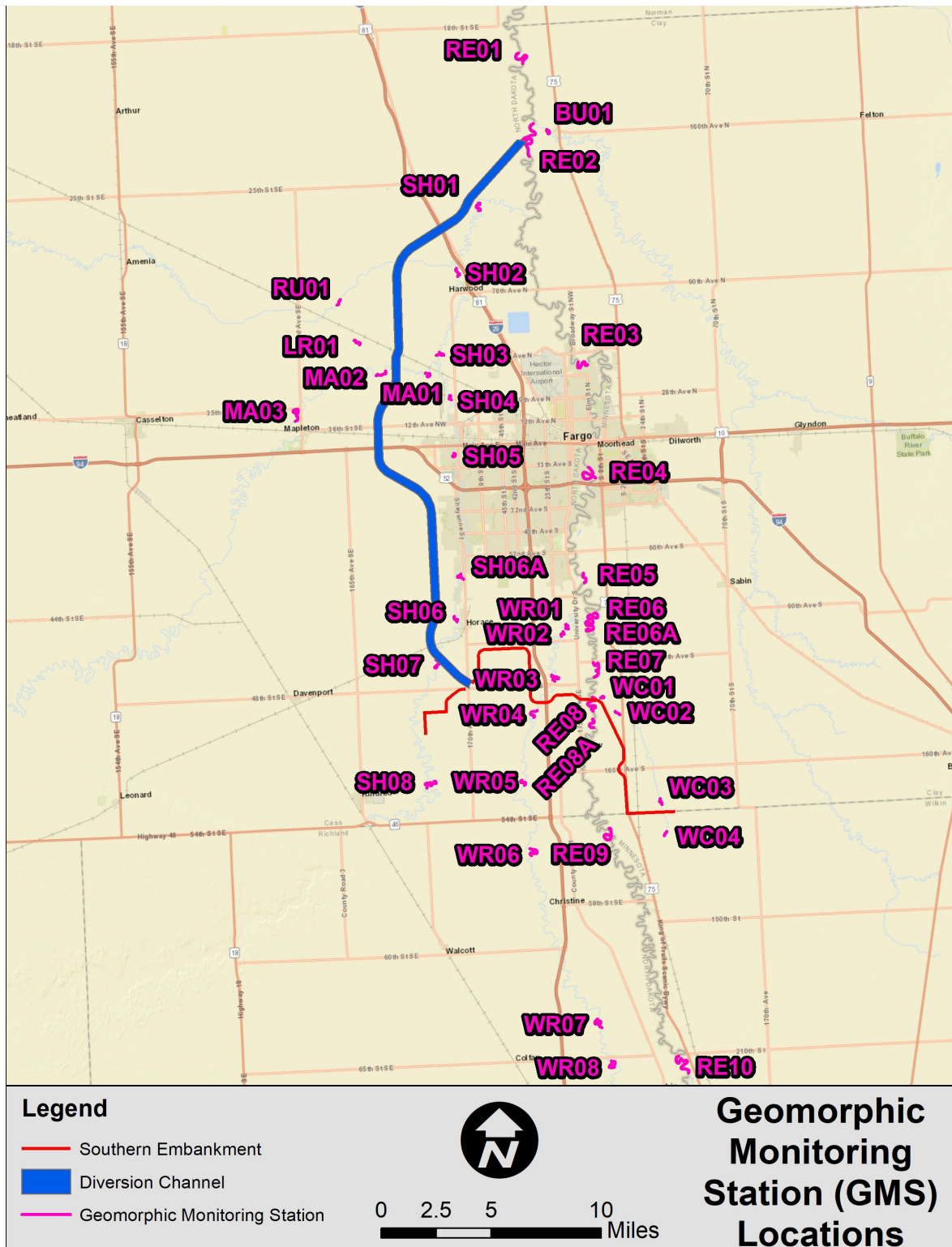

Figure 2. Geomorphic Monitoring Station Locations.

NOTE: 1) RE02 is divided into two GMS, one on each side of Diversion Channel Outlet.
 2) Move the three most upstream cross-sections in RE-08 into RE-08A, delete RE-08.

Geomorphic adaptive management triggers were discussed with the AMT and GMT during a series of meetings spanning April through June 2021 and from April through May 2022. The selected adaptive management triggers are data-driven and technically justified and establish triggers that, if exceeded, require additional action to be taken by the GMT and AMT. These actions are detailed in the attached Geomorphic Monitoring Plan. An overview of the selected geomorphic adaptive management triggers is presented in the following paragraphs. It is noted that if it is the GMT’s judgment that other significant change is occurring throughout the system and is not being captured by the currently established triggers, the GMT can recommend to the AMT that additional action is needed without exceedance of one of the pre-established geomorphic triggers.

Geomorphic Adaptive Management Trigger 1: Entrenchment Ratio

Table 9 displays the Entrenchment Ratio action triggers for each stream in the Project vicinity. The methodology that will be used to calculate Entrenchment Ratios in post-Project geomorphic assessments for the purposes of comparing to these action triggers is outlined in the Geomorphic Monitoring Plan attachment.

Table 9: Entrenchment Ratio Action Triggers by Stream

Stream	Action Trigger
Buffalo River	<2.3
Lower Rush River	<2.3
Maple River	<2.3
Red River	<2.3
Rush River	<2.3
Sheyenne River	<2.3
Wolverton Creek	<1.8
Wild Rice River	<2.3

The USACE is working with WEST to develop recommendations to evaluate changes to the action triggers that would consider either values above those recorded in the three intervals of the baseline data at each location or a set percentage above the last measured change for each GMS. The evaluation will consider causes and impacts of changes.

The USACE is working with WEST to develop recommendations for Entrenchment Ratio action triggers by GMS instead of by stream.

The USACE is working with WEST to develop recommendations for Entrenchment Ratio investigation triggers by GMS instead of by stream. The Entrenchment Ratio investigation triggers would be based upon a percent difference to the historically observed values. The investigation triggers would be set to 5 percent, 10 percent, or 15 percent increments based upon the maximum differences that have been observed for each GMS.

Geomorphic Adaptive Management Trigger 2: Bank Height Ratio

Table 10 displays the Bank Height Ratio triggers for each stream in the Project vicinity. The methodology that shall be used to calculate Bank Height Ratios in post-Project geomorphic

assessments for the purposes of comparing to these action triggers is outlined in the Geomorphic Monitoring Plan attachment.

Table 10: Bank Height Ratio Action Triggers by Stream

Stream	Action Trigger
Buffalo River	>1.4
Lower Rush River	>1.5
Maple River	>1.3
Red River	>1.4
Rush River	>1.6
Sheyenne River	>1.5
Wolverton Creek	>2.2
Wild Rice River	>1.4

The USACE is working with WEST to develop recommendations to evaluate changes to the action triggers and associated methodologies that would consider either values above those recorded in the three intervals of the baseline data at each location or a set percentage above the last measured change for each GMS. The evaluation will consider causes and impacts of changes.

The USACE is working with WEST to develop recommendations to revise the methodology in this section of the GMP to use a fixed bankfull elevation for determining BHR and to develop a list of assumptions to check after each sampling event and after the third cycle of sampling.

The USACE is working with WEST to develop recommendations for BHR action triggers by GMS instead of by stream.

The BHR investigation triggers shall be BHR+0.1 for all sites. The USACE is working with WEST to develop investigation triggers for each GMS to monitor system changes

Geomorphic Adaptive Management Trigger 3: Bank Line Location

Triggers that would require the GMT and AMT to take further action regarding changes in bank line locations are outlined below:

- In the event any member of the GMT or AMT receives a complaint from the public stating that the Project is causing increased bank line movements in areas not within the immediate vicinity of a monitored cross section, the GMT member who is the recipient of the complaint and a Non-Federal Sponsor representative shall meet to evaluate the complaint and compare the observed bank line movement that resulted in the complaint against historically-observed movement within the same area and notify the GMT of the complaint and their screening analysis. If bank line movement appears to have occurred, the GMT shall meet to provide a consensus-based response to the AMT stating the following:
 - Whether the GMT judges the observed bank line movement that resulted in the complaint to be inside or outside the range of natural variability for that reach of the stream

- If outside the range of natural variability, whether the GMT judges the observed bank line movement to be the result of the Project
- If the result of the Project, the recommended corrective action
- Post-Project construction geomorphic assessments will evaluate bank line locations and any associated movement and apply judgment to highlight areas that may fall outside of normal ranges (referring to the WEST 2012, 2019, and 2021 reports as background). These areas will be further investigated by the GMT. The GMT will then provide a consensus-based response to the AMT stating the following:
 - Whether the GMT judges the observed bank line movement that resulted in the complaint to be inside or outside the range of natural variability for that reach of the stream
 - If outside the range of natural variability, whether the GMT judges the observed bank line movement to be the result of the Project
 - If the result of the Project, the recommended corrective action

Geomorphic Adaptive Management Trigger Exceedance

In the event a geomorphic adaptive management trigger is exceeded, the Geomorphic Monitoring Plan identifies specific actions the GMT will take. Generally, the GMT will first evaluate whether the trigger exceedance is attributable to the Project and, if possible, to what degree. If attributable, the GMT will then evaluate whether the impact is detrimental to stakeholders. If attributable and detrimental, the GMT will provide one or more recommended corrective actions for consideration to the AMT that are commensurate with the detrimental level of impact and with the level of attribution to the Project. The GMP has established a collaboration process and timelines for working through any trigger exceedance so as to allow for a maximum of 60 days to elapse between trigger notification and recommendation.

- Protocols and Standards:
 - A number of protocols are defined in the GMP related to all areas of geomorphic assessment, including calculation of entrenchment ratios, calculation of bank height ratios, determining aerial imagery-derived bank line locations, collecting survey data, analyzing sediment samples, and conducting Rosgen assessments.
 - Data will be made available in the RIVERMorph format and stored by the Non-Federal Sponsors in an electronic repository accessible by all GMT and AMT members via a web interface. The current storage location for this data is the Aconex site (<https://us1.aconex.com/Logon>).
- Geomorphic Assessment Schedule:
 - Pre-Construction: A total of three pre-construction geomorphic assessments were conducted. The three pre-construction geomorphic assessments were conducted in 2010/2011, 2018, and 2020. The GMT adapted the survey plan used in 2010/2011 with additional and revised cross section survey locations, longitudinal profiles, and overbank deposition assessments for a more complete pre-construction geomorphology

monitoring survey plan that was implemented in the 2018 collection and further refined for the 2020 collection. After the 2021 assessment is completed, the GMT and AMT will refine the GMP as appropriate.

- During Project Construction Prior to Operations: Pre-operation sampling event may occur during construction if a large flood event occurs that would have resulted in operation of the Red River and Wild Rice River structures if the Comprehensive Project construction was complete which is defined as an event when the combined flows at the USGS gages on the Red River at Enloe and on the Wild Rice River at Abercrombie exceed 21,000 cfs, equivalent to slightly less frequent than a 5% annual exceedance probability event. In the event of multiple successive years of project operation floods, the GMT will meet to recommend whether the second or later events are monitored and at what level of detail based on the data collected from the previous event(s). After successive events close in time, the GMT will meet to see if it can identify criteria for supporting the decision-making process related to future assessments.
- Post-Construction: Conduct a total of three initial post-construction geomorphic assessments at five-year intervals following completion of Project construction. If no significant changes are noted after these initial three assessments, the assessment frequency may be reduced if the GMT and AMT deem that to be appropriate. After the third initial post-construction assessment is completed, the GMT and AMT will refine the GMP as appropriate.
- If the Project is operated (which will occur only if the combined inflows at the USGS gages on the Red River at Enloe and on the Wild Rice River at Abercrombie exceed 21,000 cfs, equivalent to slightly less frequent than a 5% annual exceedance probability event), a geomorphic assessment will occur as soon as possible following the event and the GMT may recommend the use of a post-operation assessment as a substitute for a regularly-scheduled geomorphic assessment. In the event of multiple successive years of project operation floods, the GMT will meet to recommend whether the second or later events are monitored and at what level of detail based on the data collected from the previous event(s). After successive events close in time, the GMT will meet to see if it can identify criteria for supporting the decision-making process related to future assessments.
- Communications:
 - AMT will be notified of all GMT meeting times, dates, agendas, and meeting notes.
 - GMT members are responsible for informing the AMT of upcoming personnel changes and provide an agency authorized alternate or replacement upon retirement or reassignment.
 - GMT will be notified by the AMT and/or Sponsors of geomorphic issues or concerns identified outside of the regular monitoring process as soon as possible.

4.5. Water Quality

A Water Quality Monitoring (WQM) Study has been set up to provide a baseline for water quality conditions and to monitor changes during and after Project construction.

The primary objective of this study is to sample and analyze water quality within the Project area before, during, and after construction to assess river response to the Project. Gages included in the WQM Study are to be monitored in a consistent manner. Statistical analyses of the data (e.g., load and trend analysis) are to be reported to the USACE, the GMT, and the AMT. Secondary objectives of this study are to leverage existing flow data, water quality data, personnel expertise, and on-going water quality programs within general Project area as the WQM Study foundation. The existing water quality data network will be used to fill in any data gaps for records collected before, during, and after construction to aid in assessing river response to the Project. The study personnel will proactively learn and share their understanding of the system and the monitoring network during the phased WQM Study to allow for betterment of future scopes-of-work under this program. The WQM Study is planned to be phased into three separate agreements with an initial three-year termed agreement started in FY 2019. The second agreement is planned to be adapted from findings of the first study and the construction progress and is planned to be executed at the contract end of the first agreement for an additional four years. The third agreement, again adapted as needed, is planned to be executed at the conclusion of the second agreement for an additional five years. At a minimum, it is anticipated that the third phase of the WQM Study will include a trend analysis comprising data collected during all three planned phases of the WQM Study.

Ten sampling locations are part of the monitoring program. Five locations are on the Red River of the North (Halstad, Georgetown, Harwood, Fargo, and Hickson), two locations on the Sheyenne River (Kindred and Harwood), two locations on the Wild Rice River (Abercrombie and St. Benedict), and one location on the Maple River (Below Mapleton). During times of normal flow conditions (i.e., non-flood event), a standard sampling protocol will be followed (eight samples per year).

All ten sites are sampled for major ions, trace metals, nutrients, TOC, DOC, bacteria, pesticides, and suspended sediment. Two sites on the Red River of the North (near Georgetown and Hickson) include continuous water quality monitors for water temperature, specific conductivity, pH, and dissolved oxygen.

Water Quality Flood Event Monitoring Triggers

During flood events, samples will be collected at the same locations as described above for the Maple, Sheyenne, and Wild Rice rivers. During construction, additional water quality sampling will not occur on the Red River because information from the continuous water quality monitors will be available for review. For the Maple and Sheyenne Rivers, a “flood event” is defined as occurring when the National Weather Service’s forecasted peak flow at either the Maple River or Sheyenne River gage (shown in Table 1) exceeds the 10% annual chance exceedance (ACE) event flow. The 10% ACE definition of a flood event for these river systems was selected based on a review of hydraulic modeling results that indicated that flows begin to inundate the floodplain during events of this size. For the Wild Rice River, a flood event is defined as occurring when the summation of

forecasted flows on the Wild Rice River and Red River exceeds 21,000 cfs at the Wild Rice and Red River gages, as indicated in Table 11.

Table 11. Monitoring Triggers for Defining a Flood Event

River System	WMS Study Gage	Flow Threshold (cfs) for Flood Event
Maple River	Below Mapleton (05060100)	6,280
Sheyenne River	Harwood (05060400)	4,190
Red River and Wild Rice River	Summation of Flows at: on Red River at Enloe (0505152130) and Wild Rice River at Abercombie (05053000)	21,000

Annual workshops are planned to keep stakeholders informed and allow for adaptive management of the monitoring regime. USGS Scientific Investigation Reports (SIRs) are expected at the end of the pre-project, construction, and post-construction periods. A Final SIR will compute trends and loads using R-QWTEND statistical analysis package.

4.6. Invasive Species Monitoring

Invasive species management is related to aquatic species and vegetative invasive species. During construction and post-construction, spread of invasive species at wetlands and other landscaping areas will require construction in accordance with specific criteria for Minnesota and North Dakota for aquatic and terrestrial invasive species, as described in Section 2.5.

Aquatic Invasive Species Monitoring

During construction and post-construction, contractors will operate in accordance with an approved aquatic invasive species management plan. The plan would require equipment that would be in contact with infested waters to be decontaminated prior to entering the water and before leaving the site. Methods for decontamination could include one of the methods described in Section 2.5. Use and cleaning of equipment will be monitored and documented when equipment enters or leaves the water body.

Zebra mussel monitoring plates on the Red River Structure and Wild Rice River will be monitored on an annual basis. Mussel counts will be recorded and shared with the AMT to provide informal information to the resource agencies. No triggers or response actions would result from this data.

Vegetative Invasive Species Monitoring

Post-construction vegetative invasive species monitoring would occur in areas planted with native species, including wetlands habitats. The monitoring results will be compiled and described in monitoring reports to be provided to the AMT. Non-forested wetland habitat monitoring in the Diversion Channel will occur annually until the invasive and non-native species performance standards listed below are met for two consecutive years. The forest habitat would also be monitored for invasive and non-native species at the fifth and tenth year following planting, and

every five years thereafter until the invasive and non-native species performance standards are met for two consecutive monitoring events.

Performance Standards:

By the third going season, areas one-quarter acre in size or larger that have greater than 50 percent areal cover of invasive and/or non-native species will be treated and replaced with native species in non-forested and forested habitats.

A combination of vegetation control methods would be used including, mowing, burning, disking, and/or mulching; or, if appropriate, biocontrol and/or herbicide treatments.

4.7. Fish Stranding

Fish stranding will be evaluated following Project operations. The evaluation will be for areas of the upstream staging area that are not otherwise flooded under without Project conditions. Please reference Figures 1, 2 and 3 in Attachment C. These provide inundation areas for both With and Without Project for the 4%, 2% and 1% annual flood probability. Maps provided in Attachment C and associated shapefiles will be the reference point for floods at or below the referenced magnitude (e.g., floods between the 4% and 2% will reference the 2% map with transects occurring in areas flooded with the Project that would not be flooded without).

The evaluation will be performed by the Non-Federal Sponsor as a part of the AMMP and the Project's O&M requirement. The Biotic Resource Monitoring Team will be contacted prior to or at the onset of Project operation and coordination will continue as waters recede. Team members will be invited to participate in field activities and will be involved with this process to the full extent they are able. Note that the precise timing of an evaluation will be dependent on hydrology and Project operations. Flexibility will be needed to perform the evaluation at an optimal time.

Monitoring fish stranding will use a two staged approach. The first is a Reconnaissance Stage to quickly evaluate if a fish stranding/kill event has occurred (MnDNR defines this as a Consequential Fish Kill). If the Reconnaissance Stage identifies a stranding/kill event, the second stage is a Detailed Evaluation Stage to quantify/enumerate fish loss.

Note that a separate discussion is included in a later section for fish that may become trapped in the Drain 27 wetland mitigation complex. A separate sampling and rescue effort will be employed to remove fish from this feature and return them to the Wild Rice or Red Rivers.

- Reconnaissance Stage:

When the Project operates, this first stage will be performed as water is receding from the upstream staging area. This stage will have a two-part, phased approach. The cumulative level of effort will be approximately one day, broken across approximately two half-day events.

- Reconnaissance Stage, Phase 1

- Observe "field" sites within the upstream staging area. These are intended to be agricultural fields and other broad, open areas. Effort will be made to survey these areas

- within seven days of them generally being drained following Project operations, though flexibility is needed given that field conditions could be difficult for access and sampling.
- Perform windshield surveys to quickly view areas and consider if there's an obvious fish stranding event.
 - Periodically along travel routes, and/or based on the windshield surveys, do on-site walking surveys in select areas where fish may be likely to strand.
 - It is assumed this phase would take approximately a half-day. Figure 4, 5, and 6 in Attachment C provide a suggested route to perform windshield surveys (based on the magnitude of flood). Staff will allocate enough time to walk areas of specific interest. This should include frequent stops along areas of concern (e.g., areas where dead fish may collect). Identified paths in Figures 4, 5 and 6 in Attachment C could also be used for walking assessments (along field edges and roadside ditches, or into fields if access available), but these will ultimately need to be adapted based on field conditions and access or available rights-of-entry.
 - Fish collected will be identified, measured when practical, and photographed. Data will be recorded on datasheets.
- Reconnaissance Stage, Phase 2
 - Observe “drainage path” sites for receding waters both along natural waterways and new drainage swales established in the staging area. These are intended to be corridors of flow where fish would presumably find their way back to the Red or Wild Rice Rivers, or down the diversion channel. Focus areas likely would include the borrow pit and borrow ditch (the dashed line in Figures 4, 5, and 6 in Attachment C), and potentially drainage swales within the staging area. Access to the borrow ditch would be available between the toe of the embankment slope and the borrow ditch where there will be a bench for maintenance access. Assessment could also occur in other drainage areas, such as the swale leading to Drainage Ditch 27 and the drainage network leading to the borrow pit.
 - Agency representatives will be consulted to finalize the locations based on site access, field conditions and how the draining process has progressed. Based on modeling of the staging area, it is anticipated that Reconnaissance Phase 2 would occur from 4 to 8 days following Reconnaissance Phase 1 but is entirely dependent on conditions with that particular flood event.
 - Focus areas to stop and observe along drainage areas could include riffle-type locations, willows, beaver dams, etc. These areas tend to collect fish.
 - Fish collected will be identified, measured, and photographed. Data will be recorded on datasheets.
 - Triggers that Require Second Stage Evaluation

The following are identified as the triggers requiring a detailed evaluation (what MnDNR has defined as a Consequential Fish Kill).

 - 5 Lake Sturgeon of any size OR
 - 5 Channel Catfish >24" OR

- 10 Walleye >15" OR
- 10 other sport fish of public value as defined by Minnesota Rule 6133.0080, of the "Quality" size class or larger as defined by Gabelhouse 1984.

If triggers are met in Reconnaissance Phase 1, a detailed evaluation of the same broader staging area would occur. Similarly, if triggers are met in Reconnaissance Phase 2, a detailed evaluation of the drainage corridors would occur for areas leading from the staging area to the Red or Wild Rice Rivers, or diversion channel.

Results of the two Reconnaissance stages will be coordinated within a day of completion with NDGF, MnDNR, and USFWS.

- Detailed Evaluation Stage:
 - If a trigger is met, perform a detailed evaluation of either the broader staging area which would not have been inundated under the without Project conditions and/or the drainage paths leading out of the staging area.
 - Detailed evaluations will follow the protocol employed in American Fisheries Society Special Publication 35 (Southwick and Loftus, 2017). Evaluations of the broader staging area would generally follow the protocol for lakes sampling; evaluations for drainage paths would follow the protocol for rivers/streams sampling.
 - The USACE and the Non-Federal Sponsors will work with agencies and external experts to develop a sampling approach with a practical number of transects for estimation of total fish stranding/kill. Sampling must be able to be completed within 1-3 days for a crew of two people. Considerations to sampling approach should include field conditions, property access, and other factors that could influence access or efficiency for data collection. As such, transect number and location needs to be flexible and may only be partially planned in advance of the flood. Consideration will be given to aerial surveys via drone technology as a potential tool for data collection, especially for detailed evaluations. While there are many limitations to doing the surveys remotely, techniques and technology will continue to improve and could be a viable option by the time fish stranding surveys would be needed (e.g., 2027 and beyond).

Number of Fish Stranding Evaluation Events

If the Project operates three times and the reconnaissance field surveys do not result in triggers for a Consequential Fish Kill, then it will be assumed that the Project does not result in substantial fish stranding and stranding evaluations will cease. This standard would be applied to both areas considered in the Reconnaissance phase (e.g., field sites and drainage path sites). Note that if the first three events are all small or similar sized events (e.g., 30-year events or less) the Non-Federal Sponsors will collaborate with the AMT to confirm if future monitoring should consider one more event if that event will be significantly different (e.g., a 50- or 100-year event). Also note that if the Project has operated three times without incident and no monitoring is planned, yet a fish kill or fish stranding is reported by the public or resource agency after a subsequent event, then the Non-Federal Sponsors will respond with a reconnaissance level investigation and move to the detailed evaluation phase if triggers are met.

Mitigation

Southwick and Loftus (2017) provides the technical approach to estimate numbers of fish lost due to stranding. They also provide guidance on applying monetary values on lost fish, based on species and size. This can be applied to estimate a monetary loss. The MnDNR and NDGF have agreed that restitution values for lost fish in the staging area will be split 50/50, with monetary values defined by Minnesota Rule 6133.0080. MnDNR retains statutory authority to assess penalties for fish kills in Minnesota resulting from project operations. In addition to a payment for lost fish, both states have expressed an interest in modifying field conditions, if possible, to minimize risk for future stranding events. This could range from a relatively easy, low-cost exercise (e.g., debris removal from culverts) to a much more expensive effort to improve drainage (e.g., extensive grading or upgrading culverts). If a Consequential Fish Kill occurs, the Non-Federal Sponsors will work with agency partners to identify the best approach to address the issue for the current fish mortality event, as well as in future years, using the monetary value of fish loss as a reference point or guide. This will need to include how any monetary payment is divided up between the states.

Drain 27 Wetland Complex

This wetland complex drains portions of the upstream staging area and includes a weir to maintain minimum water elevations during most years. This provides hydrology to support a wetland community implemented for mitigation, but also provides a barrier fish may not move downstream over. Fish could become trapped within this feature following floods. In addition, common carp that become trapped would likely uproot vegetation, limiting the ecological effectiveness of the mitigation feature.

Following operation of the Project, sampling will be done within the wetland to assess fish presence. A two-stage approach will be used, with an initial stage to determine fish presence, and a second to remove fish and transport back to the Red River. Exact gear types and triggers for moving to a fish removal operation are still under development. Depending on location and conditions, this potential sampling could include electroshocking, fyke or trap netting, or other methods. The evaluation will be performed by the Non-Federal Sponsors as a part of the AMMP and the Project's O&M requirement. The AMT will be invited and involved with this process to the full extent they are willing/able to do so. The timing of this evaluation can be more flexible but should be performed within 30 days of the end of Project operations.

Specific gear types and level of effort will be fine-tuned in collaboration with the AMT once the wetland complex is built. Initial sampling is intended to take approximately a day to assess fish presence within the wetland. This could include a minimum of two hours of run-time for electrofishing; a set number of seine hauls; or set number of overnight fyke-sets.

Triggers that Require a Fish Removal Operation

Triggers will follow with those outlined above for fish stranding. These will need refinement and finalization. These will be based on the following level of effort:

- 1 hour of electroshocking
- 5 overnight sets of a fyke or trap net
- Other

Triggers for the above effort

- 5 Lake Sturgeon of any size OR
- 5 Channel Catfish >24" OR
- 10 Walleye >15" OR
- 10 other game fish as defined by the North Dakota 2020-2022 Fishing Proclamation, of the "Quality" size class or larger as defined by Gabelhouse 1984.

If the above triggers are met with the given level of effort, a fish removal operation will commence. If this occurs, it will continue via active sampling (e.g., shocking or other) until fewer than five of the target species (any size) are collected for the same level of effort for given gear types listed above. If a different active or passive collection method is used, the Non-Federal Sponsors will work with the AMT to develop a similar endpoint.

Any live fish collected during a removal operation will be transported and returned to the Red River using typical methods (e.g., stock truck or similar). The Non-Federal Sponsors will coordinate with the resource agencies on the appropriate transport methods. All results of the collection effort will be recorded and reported to the AMT.

The exception to the fish removal identified above is if the fish collected are common carp or any other invasive fish. If the only fish collected outside of the defined triggers are common carp or other invasive fish, the AMT will identify the best approach to manage/remove and dispose of remaining fish. This may occur outside of the specified 30-day window, and could include water level management, continued physical removal, chemical treatment (rotenone), predator fish stocking, or other actions.

4.8. Drayton Dam

Drayton Dam will be constructed as a MnDNR permit requirement for this Project. As directed in condition 27 of MnDNR permit 2018-0819, the design of the Drayton Dam Project was collaboratively worked on with the MnDNR, in addition to other resource agencies, to ensure effective fish passage. The design incorporates the best available design parameters for slope, weir alignment, pool depth, and head-loss across boulder weirs.

Monitoring Activities

Though not required in the permit, velocities through the Drayton Dam Project will be measured after the Project is complete, as requested by the DNR, to capture the "as-built" condition for water

movement through rock ramps. Measurements will be taken in resting pools between weirs and in gaps between boulders across the entire cross-section. Measurements will occur within one year of Project completion and will be limited to a single sampling effort. Additional monitoring of the fish passage, or any modifications to the structure based on velocity or other observations, would be addressed in state and local permits, such as the individual Drayton Dam permit from the MnDNR.

4.9. Additional monitoring needs

Coordination with agency members during preparation of the 2019 SEA identified additional monitoring concerns for the Project. These include needs for species or biota of special concern, and invasive species. Monitoring will include the following activities:

- Bald eagle nests would be monitored every spring through the completion of all construction. The Project area would continue to be monitored during the upcoming construction years to ensure that no new nests would be impacted by Project construction.
- Similar to eagle surveys, there would be raptor nest surveys completed in the spring of the year preceding construction within or near any affected wooded areas.
- Monitoring would be completed on an annual basis in accordance with the OMRR&R and AMMP.

5. Costs and Schedules

5.1. Monitoring Schedule and Costs

Table 12 provides a summary of what monitoring has been completed and a tentative plan for additional monitoring prior to or during Project construction. Because of uncertainties with the Project schedule, annual funding, field conditions, and the results of earlier surveys, the need and timing of additional survey work could shift. Note that two of three events of aquatic biotic/habitat surveys have been completed for impact areas; all three geomorphic assessments have been completed. The schedule for surveys of aquatic habitat mitigation sites will be developed once mitigation plans are finalized.

Schedules for individual mitigation projects will be developed as they are designed and constructed. A general summary of the timing and information that will be collected for each category of mitigation project is provided in Table 12; additional description can be found in Section 4.

Table 12. Estimated scheduled for pre- and post-construction Project monitoring (in order of discussion)

Monitoring Event	Year	Status
Aquatic Biotic Monitoring		
Aquatic Biotic/Habitat, first round	2011 & 2012	Completed
Aquatic Biotic/Habitat, second round	2017	Completed
Sheyenne Fish Observation in Diversion Channels	2025*	Initial pre-design fish surveys completed in 2022. Additional surveys to be performed prior to construction
Sheyenne River Field Surveys of Rock Rapids Fishways for Sheyenne River Mitigation Project	TBD	To determine species composition and size structure of fish below the fishway.
Sheyenne River IBI Observations for Sheyenne River Mitigation Project	TBD	Post-construction surveys would occur at the same locations as monitored in 2012 and 2017.
Drayton Dam Velocity Measurements	2024	A single monitoring event will be conducted after construction to capture as-built conditions
Red River Structure Velocity Measurements	TBD	Average cross section velocities at the Red River Structure will be measured at discharges close to 2,900 cfs, 8,100 cfs, and 10,700 cfs
Maple River and Sheyenne River Fish Passage Aqueducts Acoustic Doppler Current Profiler	TBD	Determination of velocities in the aqueducts

Monitoring Event	Year	Status
Fish Stranding in the Upstream Staging Area	TBD	Reconnaissance Stage (Phase I) and possibly a Detailed Evaluation Stage (Phase II) after a flood storage event
FOREST MITIGATION MONITORING		
Floodplain Forest, Post-Construction	2010-2031*	Forest mitigation areas will be monitored annually for the first 5 years after planting.
WETLANDS MITIGATION MONITORING		
Wetlands, Post-Construction	2010-2031*	Wetland mitigation areas will be monitored annually for the first 5 years after planting or once criteria has been met.
GEOMORPHIC MONITORING		
Geomorphic Assessment (Pre-construction, first round)	2010/2011	Completed with report finalized in October 2012
Geomorphic Assessment (Pre-construction, second round)	2018	Completed with report finalized in September 2019
Geomorphic Assessment (Pre-construction, third round)	2020	Monitoring complete, report finalized in October 2021
Geomorphic Assessment (During Project, Construction Event)	Event dependent	Report to AMT within 1 year of completion of field investigation effort. (<i>USACE Until October 2022; Sponsor October 2022 and beyond.</i>)
Geomorphic Assessment (Post-Project, first round)	Within 1 year of Project Completion	Future TBD: Report final within 2 years to establish Post-FMM Project conditions.
Geomorphic Assessment (Post-Project, second round)	+ 5 years after Round 1	Future TBD: 2 nd Post-Project Assessment
Geomorphic Assessment (Post-Project, third round)	+ 10 years after Round 1	Future TBD: 3 rd Post-project Assessment. GMT initiate meetings to evaluate within 90 calendar days of finalization of third post-project Geomorphic Assessment Report. GMT provides summary and recommendations to AMT within 180 days.
WATER QUALITY MONITORING		

Monitoring Event	Year	Status
Water Quality Monitoring (Pre-construction) w/ Flood Event Monitoring	FY 2019- 2022	3-year-term, completed Monitoring Plan adaptable following evaluation of first- term monitoring assessment. Including Flood event 2020. Final report finalized in early 2023.
Water Quality Monitoring (Construction) w/ Flood Event Monitoring	FY 2022- 2026*	4-year term; Re-assess, evaluate, adapt.
Water Quality Monitoring (Post-Construction) w/ Flood Event Monitoring	FY 2026- 2031*	5-year term; Re-assess, evaluate, adapt.
INVASIVE SPECIES MONITORING		
Inspect Zebra Mussel Monitoring Plate at Red River and Wild Rice Structures	Annually	Future TBD: Once the structures are constructed annual inspections will begin.
EAGLE AND OTHER RAPTOR MONITORING		
Eagle/Raptor Monitoring	Annual	Spring eagle and raptor surveys will occur in the Project area until construction is complete.

*Timing dependent on field conditions, logistical concerns, etc. Timing may shift as needed.
The number and timing of events for aquatic habitat mitigation sites will be set once the mitigation plans are finalized

The schedule for post construction surveys will be set once the Project is largely constructed.

Table 13 provides an estimate for pre- and post-construction monitoring costs. Specific line-item costs have not been included for observations for fish stranding or floodplain forest success as these activities would be likely be a relatively small efforts accomplished by the Non-Federal Sponsors. Invasive species monitoring will be included as a component of both forestry and wetlands monitoring. The estimate below will be revised as Project costs are updated to reflect current dollars as well as any necessary changes. Note that monitoring estimates for mitigation sites could increase or decrease depending on the number, location and type of mitigation and monitoring sites ultimately selected.

Table 13. Estimated monitoring costs for the AMMP (in order of discussion)

Project Phase	Studies	Cost (in 2020 dollars)
AQUATIC BIOTIC MONITORING		
Pre-Project	Sheyenne River Fish Observation in Diversion Channels	\$50,000 (per year)
Post-Project	Field Surveys of Rock Rapids Fishways (Sheyenne mitigation) to ensure maintaining design criteria.	\$10,000 (per event). Assumes each event monitoring two rock rapids fishways.

Project Phase	Studies	Cost (in 2020 dollars)
Post-Project	Sheyenne River IBI Observations.	\$100,000 (per event)
Post-Project	Maple River and Sheyenne River Fish Passage Aqueducts Aqueduct Acoustic Doppler Current Profiler	\$10,000 (per event, per aqueduct)
Post-Project	Fish Stranding Stage 1 (Recon)	\$15,000 per event (includes Phase I and II).
Post-Project	Fish Stranding Stage 2 (Detailed Evaluation)	\$25,000 per event (includes Phase I and II).
Post-Project	Drain 27 Fish Removal	\$25,000 per event
Post-Project	Velocity measurements at the Red River Structure	\$5,000 (per event)
Post-Project	Velocity measurements at Drayton Fish Passage	\$15,000
FOREST MITIGATION MONITORING		
Post-Project	Forest Monitoring (annually for first 5 years)	\$50,000 (per event)
Post-Project	Forest Monitoring (every 10 years or following major flood)	\$50,000 (per event)
WETLANDS MITIGATION MONITORING		
Post-Project	Diversion Channel Wetlands Monitoring (5-10 years)	\$200,000 (annually)
Post-Project	Drain 27 Wetland (5 years)*	\$65,000 (annually)
GEOMORPHIC MONITORING		
Construction	Geomorphic Assessment (only if an event sufficient to initiate Project operations, if the Project were complete, occurs, since all regularly scheduled pre-Project monitoring is complete)	\$1,000,000 (per event)
Post-Project	Geomorphic Assessment (3 rounds and re-evaluation). Currently anticipate assessments conducted in 2027, 2032, and 2037, with reports delivered to the AMT the following year. Timing of assessments beyond 2037 dependent upon AMT and GMT evaluation after 2037 assessment report is completed.	\$1,000,000 (per round)
Post-Project	Geomorphic Post-Flood Event Assessment (only in the event Project operations occur)	\$1,000,000 (per event)
WATER QUALITY MONITORING		
Construction	Water Quality Monitoring Term #2 Report delivered to AMT in 2027 covering water years 2023-2026. Effort may be adjusted by AMT after evaluation of Term #1 data.	\$1,333,333 (total estimate for all four years at pre-construction monitoring levels)

Project Phase	Studies	Cost (in 2020 dollars)
Post-Project	Water Quality Monitoring (Term #3). Report delivered to AMT in 2032 covering water years 2027-2031. Effort may be adjusted by AMT after evaluation of Term #2 data.	\$1,666,666 (total estimate for all 5 years at pre-construction monitoring levels)
INVASIVE SPECIES MONITORING		
Post-Project	Inspect Zebra Mussel Monitoring Plate at the Red River and Wild Rice River Structures	\$500 (annually)
EAGLE AND OTHER RAPTOR MONITORING		
Construction	Annual spring monitoring for eagle and other raptor nests near construction sites	Cost part of construction costs

* This period may be shortened if the monitoring reports demonstrate that the mitigation site(s) has met its vegetation and hydrology performance standard(s) in two consecutive reports and the AMT concurs that additional monitoring is not required.

** Table does not include costs for items still needing further development, such as potential fish observations through the Sheyenne aqueduct and adjacent areas of the Sheyenne mitigation project.

The Non-Federal Sponsors are responsible for funding long-term operation and maintenance, including the monitoring costs and unforeseen mitigation needs that may arise due to Project operation. On June 10, 2021, the Metro Flood Diversion Authority and Cass County Water Resource District (CCJWRD) entered into a Master Indenture of Trust with the Bank of North Dakota serving as Trustee and the City of Fargo serving as Fiscal Agent. The Master Indenture of Trust establishes and controls multiple funds and accounts for the Project, including but not limited to the Operations and Maintenance Fund that will be used to fully fund operations and maintenance of the throughout the life of the Project. The Operations and Maintenance Fund is funded through a variety of revenue sources (as more fully set forth in the Master Indenture of Trust), including sales and use taxes from the City of Fargo and Cass County in North Dakota that would be in excess following payment of debt obligations issued for the capital cost of the Project, the imposition and levy by CCJWRD of Fargo-Moorhead Flood Risk Management District No. 1 maintenance levy upon benefitted lands in North Dakota, and the Storm Water Maintenance Fee collected within the City of Moorhead, Minnesota, and funds from Clay County, Minnesota.

6. Data Storage

The AMMP will generate substantial amounts of data, information, and reports over time. The data and subsequent reports should be accessible and shared to avoid redundancy and analysis purposes as well as stored as part of the monitoring record and for future data needs. The USACE and the Non-Federal Sponsors will work with the AMT to develop a repository for this information. This will likely be a web-based system, providing access to summary reports and potentially raw data. All AMMP work products will be shared with the AMT when requested.

As discussed in Section 4.4 and more extensively in the Geomorphic Monitoring Plan, the current storage location for geomorphic monitoring data is the Aconex site maintained by the Non-Federal Sponsors. The Aconex site can be accessed here: <https://us1.aconex.com/Logon>.

A database is being developed to track Project impacts, mitigation sites, and monitoring. Information the database would contain includes a brief overview of each project phase/feature, access to files and maps, inspection notes and schedules. The platform would allow photos and notes to be uploaded from the field. The database would be accessible to the USACE, the Non-Federal Sponsors, and agency team members.

7. References:

- DOI 2018. Coordinating Adaptive Management (AM) and National Environmental Policy Act (NEPA). United States Department of the Interior. PEP – Environmental Statement Memorandum No. ESM 13-11. September 2018.
- EPA 1998. Development Index of Biotic Integrity Expectations for the Lake Agassiz Plain Ecoregion. EPA 905-R-96-005. September 1998.
- National Academy of Sciences 2004. Adaptive Management for Water Resources Project Planning. National Research Council of the National Academies.
- NDDoH 2011a. Development of a Fish Index of Biotic Integrity (IBI) for Wadeable Streams of the Lake Agassiz Plain (48) Ecoregion. North Dakota Department of Health. April, 2011.
- NDDoH 2011b. Macroinvertebrate Index of Biotic Integrity (IBI) for the Lake Agassiz Plain Ecoregion (48) of North Dakota. North Dakota Department of Health. May, 2011.
- Southwick, R. I., and A. J. Loftus, editors. 2017. Investigation and monetary values of fish and freshwater mollusk kills. American Fisheries Society, Special Publication 35, Bethesda, Maryland.
- USACE 2010. Regional supplement to the U.S. Army Corps of Engineers Wetland Delineation Manual: Great Plains Region (Version 2.0). March 2010.
- USACE 2012. Mussel survey at Fargo-Moorhead diversion ditch footprints, biotic sampled sites, and areas to be abandoned by the diversion ditch, Cass Co., ND, Clay Co., MN, October 2011. Prepared by Dan Kelner. USACE, St. Paul District, January 2012.
- Walters, 1986. Adaptive Management of Renewable Resources. Carl Walters. Macmillan Publishing Company. August 1986.
- West 2012. Geomorphology Study of the Fargo, ND & Moorhead, MN Flood Risk Management Project. West Consultants, Inc. October 25, 2012. Prepared for US Army Corps of Engineers, St. Paul District.
- West 2019. Geomorphology Monitoring of Rivers Potentially Affected By the Flood Risk Management Project located within the City of Fargo, Cass County, ND & City of Moorhead, Clay County, MN. September 2019. Prepared for US Army Corps of Engineers, St. Paul District.
- West 2021. Geomorphologic Monitoring of Rivers Potentially Affected By the Fargo-Moorhead Metro Flood Risk Management Project. October 2021. Prepared for US Army Corps of Engineers, St. Paul District.

Geomorphic Monitoring Plan for the Fargo-
Moorhead Metropolitan Area Flood Risk
Management Project

Attachment B of the Draft Adaptive
Management and Mitigation Plan

November 2022

1. GEOMORPHIC MONITORING PLAN OVERVIEW

The Fargo-Moorhead Metropolitan Area Flood Risk Management Project (FMM Project) will directly alter the hydrology of the Red River and tributaries in the FMM Project vicinity by partially diverting high flows. This change in hydrology has the potential to affect the geomorphic characteristics of the streams in the vicinity of the FMM Project. Therefore, this Geomorphic Monitoring Plan (GMP) was developed to monitor the geomorphic characteristics over time to allow for a data-driven evaluation of any changes in the FMM Project vicinity and, if detrimental geomorphic impacts relative to the pre-project dynamics of the system and the reference reaches occur and are attributable to the FMM Project, to implement beneficial corrective actions.

This GMP was developed collaboratively by experts representing local, state, and federal organizations referred to herein as the Geomorphic Monitoring Team (GMT). The GMP will follow the adaptive management framework as outlined in the FMM Project's Adaptive Management and Monitoring Plan (AMMP), which was developed and will be managed by the Adaptive Management Team (AMT). The scope of this GMP is reflective of the complexity and uncertainty associated with sediment and hydrologic channel interactions in a large system with many driving variables that are not completely understood. The nature of FMM Project operation (which may not occur for years or may occur multiple years in a row), and the fact that impacts in river systems (e.g., to channels, riparia, and biota) can occur abruptly are examples of the stochasticity inherent in the system which make monitoring essential in the absence of validated predictability.

For the purposes of this GMP, pre-FMM Project is defined as the time period prior to and during construction activities. Post-FMM Project is defined as the time period following construction completion of all the FMM Project features (currently anticipated to begin in 2027).

The US Army Corps of Engineers (USACE) is responsible for ensuring adherence to and execution of the GMP until 24 October 2024 with the non-Federal sponsors (Metro Flood Diversion Authority, City of Fargo, North Dakota, and City of Moorhead, Minnesota) responsible for this after this date.

The GMP shall govern if the AMMP and GMP language is in conflict, unless otherwise agreed to by the AMT.

2. GEOMORPHIC MONITORING PLAN GOALS

Monitoring how the geomorphic characteristics of each river reach in the FMM Project vicinity change through time provides necessary empirical data for assessment of the FMM Project's impacts. The first goal of the GMP is to understand what the natural and adaptive range of geomorphic changes is for each river reach and to recognize and measure changes over time. Pre-FMM Project surveys and other supporting data allow for the establishment of these baseline ranges.

The second goal of the GMP is identifying measured geomorphic change triggers that, if exceeded, would be considered to be outside the natural and adaptive ranges. The trigger exceedance cause may or may not be attributable to the FMM Project. Identifying contributing factors other than those due to the FMM Project may require obtaining additional data beyond the data specified in this GMP, such as land use records, drainage change information, and precipitation and runoff data. Evaluating the contributing factors against FMM Project influences may also require modifications to the GMP and its triggers over time based on interpretation of additional gathered data. In the event that trigger exceedance is attributable to the FMM Project and if the changes are deemed to be detrimental, this GMP guides the process for development of corrective actions.

The third goal of this GMP is to outline a framework to maintain clear and effective communication between the non-Federal sponsors, other AMMP work groups, regulatory agencies, and stakeholders/ affected parties for sharing information specific to the geomorphic aspects of adaptive management, monitoring, and corrective action taking.

3. PRE- AND POST-FMM PROJECT CONDITIONS

3.1. Pre-FMM Project Conditions

USACE has contracted with WEST Consultants, Inc. (WEST) to conduct three separate pre-FMM Project geomorphic assessments in the vicinity of the FMM Project. The first assessment was completed in 2012 using survey and field data collected in 2010 and 2011. The second assessment was completed in 2019 using survey and field data collected in 2018. Survey and field data for the third assessment was collected in 2020, with bankfull flow hydraulic models (containing bankfull top widths and bankfull flow depths) and bank line locations delineated using aerial imagery provided to USACE on 15 June 2021 for use in establishing natural ranges of variability. The full set of results and report from this third assessment are anticipated to be available in fall 2021.

WEST presented a global overview of the current river system condition in Section 10.6 of the 2012 report as follows:

“Results of the geomorphic assessment indicate that the involved study reaches are not prone to significant change in morphology over short or even moderate periods of time. Channel migration rates are on the order of a few inches per year. The erosion resistant nature of the cohesive glacial lake bed soils and the very flat gradient of the channels prevent significant changes in channel cross section geometry and results in very low rates of lateral migration. Further, the sediment supply from upstream and the surrounding landscape is generally composed of silt-and clay sized material with only minor amounts of sand-sized material. The study streams appear to have sufficient capacity to transport nearly all of the sediment supplied to them in suspension as wash load...”

Additional GMT observations of pre-FMM Project conditions in the for specific areas in the vicinity of the FMM Project features are noted in the following sections.

3.1.1. Staging Area

The Red River in the proposed FMM Project staging area is generally the starting point of taller stream banks compared to the stream banks within the proposed benefitted area. These taller stream banks are more susceptible to rotational failures due to their height and when fail contribute more sediment to the channel and result in larger changes to the riparian area. Structures crossing the Red River, such as the Cass County Highway 18 bridge, tend to induce bank failure near the structures due to concentrated flows and higher velocities during flood events. Additionally, a Red River meander cutoff appears imminent near Oxbow, ND, which will drive a geomorphic response due to the riverine slope increase.

The Wild Rice River exhibits a number of major rotational failures throughout the proposed FMM Project staging area. These failures contribute large amounts of sediment and cause changes to the riparian areas, including the collapse of large trees into the Wild Rice River channel. Some reaches of the Wild Rice River become unnavigable by boat during normal flow conditions due to the abundance and concentration of woody debris.

3.1.2. Benefitted Area

The area proposed to benefit from the FMM Project (i.e., north of the dam and east of the

diversion channel) generally consists of shorter bank heights and more abundant vegetation than within the proposed staging area. These two factors have resulted in less overall bank slumping and rotational failures within the proposed benefitted area.

3.1.3. Tributaries

Long stretches of both the Rush River and Lower Rush River have been channelized to increase flow capacity over the past few decades. These anthropogenic changes have resulted in geomorphic characteristics that deviate significantly from streams considered to be fully functioning.

In 2018, the Buffalo-Red River Watershed District began a large stream restoration effort on Wolverton Creek. As of 2021, Wolverton Creek from the upstream extent of the geomorphic monitoring area downstream to 28th Street South has been restored. Restoration has not occurred between 28th Street South and Wolverton Creek's confluence with the Red River.

The Maple River and Buffalo River are both generally considered to be stable streams with little lateral movement over the pre-Project period. Some bank collapses were observed within the Maple River reaches but these did not appear to influence the stream stability or to be the result of widespread stream instability.

The Sheyenne River is similar to the Wild Rice River, in that its tall banks are susceptible to rotational failure and collapse, impacting the riparian area. Landowner concerns with bank collapse and channel movement have been noteworthy enough to be reported on by local news organizations (<https://www.inforum.com/news/science-and-nature/1356423-Flooding-effects-Homeowners-along-Sheyenne-River-in-West-Fargo-watching-yards-trees-wash-away>). Normal to low flows in the Sheyenne River have also been artificially increased by pumping of Devil's Lake flows. According to a 2020 USACE white paper on the subject, the 50 percent annual exceedance flow has increased from 330 cfs to 560 cfs for the portion of the Sheyenne River above the Sheyenne River Diversion near Horace, ND for the period of time that the Devil's Lake pumping has occurred. The increase of low to normal flows may have an impact on the Sheyenne River geomorphic characteristics due to channel banks being saturated at higher levels and for longer periods of time.

3.2. Possible Post-FMM Project Conditions

The 2012 WEST report presented a global overview of post-FMM Project conditions predictions as follows:

“Bank stability and riparian vegetation density are expected to slightly increase in the reaches that are protected from high flows by the proposed diversion alignment.

Conversely, bank stability and riparian vegetation density are expected to slightly decrease in the staging areas upstream of the diversion alignment as a result of more frequent overbank inundation and sedimentation.”

The 2019 WEST report echoed a similar tone, with the following language:

“Because [project operations] are expected to occur on an infrequent basis, they are not expected to result in significant changes in the channel morphology over the long-term.”

While the WEST reports do not predict notable changes globally in the FMM Project vicinity, the reports do state it is possible that localized impacts may occur. Potential types and locations of impacts, including some not listed in the WEST reports, are outlined below.

3.2.1. Local Bed Aggradation

Increased bed aggradation may occur downstream of the Maple River and Sheyenne River aqueduct structures, with it more likely to occur downstream of the Sheyenne River aqueduct due to the prevalence of sand-sized material transported by the Sheyenne River (compared to clay- and silt-sized material transported by the Maple River). Bed aggradation may occur as water from the top of the water column (which typically has a lower sediment concentration) is diverted into the Diversion Channel at the aqueduct structures while water from the bottom of the water column (containing proportionally more sediment) continues across each aqueduct and into the natural river channel downstream of each aqueduct. The ability of the rivers to transport sediment will be reduced, but the proportion of sediment will not be proportionally reduced, indicating a potential for sediment deposition.

Increased bed aggradation may also occur in the vicinity of the Red River Structure and Wild Rice River Structure for the periods of time the structures are not operating, due to the increased cross-sectional area of the engineered channels and structure width, which potentially will result in lower velocities and thus, sediment deposition. It is also possible that during operation of these structure that the high flow velocities through the Red River Structure and Wild Rice River Structure will move this deposited material and some native material from the downstream portion of the engineered channel and deposit it further downstream where velocities are closer to those occurring under pre-FMM Project conditions.

3.2.2. Local Overbank Deposition and Bank Slumping

Additional overbank sedimentation on the floodplain near the Wild Rice River and Red River channels upstream of the dam is possible due to the increased flood durations and depths in this area. Any deposited material is likely to deposit on or near the stream banks, which has the potential to decrease bank stability. Less sedimentation is anticipated further away from the rivers and is not anticipated to result in geomorphic concerns.

3.2.3. Local Bed Degradation

Localized bed degradation is possible upstream of the Sheyenne River and Maple River aqueducts due to the possibility that both the aqueducts and the spillways diverting flow into the Diversion Channel are more hydraulically efficient than the existing river channels, thus reducing backwater levels and increasing velocities in the portions of the rivers upstream of the aqueducts. These increased velocities have the potential to erode the streambed, resulting in the local bed degradation.

3.2.4. Local Bank and Bed Erosion

Increased flow velocities immediately downstream of the Red River Structure and Wild Rice River Structure during operation of these structures has the potential to result in small amounts of erosion of the engineered channel and its banks and, for events less frequent than the 1/1,000 annual exceedance probability event (commonly referred to as the 1,000-year event), erosion of the natural channel bed and banks downstream of the structures.

4. GEOMORPHIC MONITORING STATION SELECTION

The GMT has adaptively managed the selection of each Geomorphic Monitoring Station (GMS) over the course of the pre-FMM Project timeframe to ensure both reference reaches that are not anticipated to be impacted by the FMM Project as well as areas that may show post-FMM Project impacts are included. Of the geomorphic monitoring stations shown in Figure 4-1, the following stations are currently defined as reference sites: RU01, LR01, MA03, SH08, WR07, WR08, RE10, and WC04.

Depending on the flood size, sites closer to the Southern Embankment (such as WR06 and RE09) may also function as reference sites to assist in evaluating geomorphic changes post-FMM Project. The sampling locations support Rosgen Classification (Rosgen, 2006) and other geomorphic assessment methods with sampling locations in stratified valley types, stream types, and in-stream habitat types represented by crossings/riffles and pools. Post-FMM Project, it may be needed to add additional GMS locations beyond those currently specified in this GMP if geomorphic changes become evident or if continued local concerns are raised to the GMT and AMT.

Terminology Note: The Red River exhibits a Crossing and Pool pattern of in-channel features where the crossings represent the zone where the direction of current crosses the channel center point as it flows in a meandering pattern from one bank to the other. Because the term “riffle” is used in classification systems of rivers with coarser bed material that cause “riffles” in the water surface at crossings, the term “crossing” and “riffle” might be used somewhat interchangeably. On the Red River and fine grained tributaries, “crossing” is used as being more descriptive of the actual river feature.

Additional detail on each GMS and its permanent, monumented cross sections is provided in the following sections.

4.1. Geomorphic Monitoring Stations Recommended for Pre- and Post-FMM Project

This section describes each of the 39 GMSs with a total of 245 monitoring cross sections that has been used for pre-FMM Project monitoring and is recommended for use in post-FMM Project monitoring. The location of each pre-FMM Project GMS is shown in Figure 4-1 and a summary of the number of cross sections in each GMS is provided in Table 4-1. Table 4-2 lists information on whether data was collected at each GMS for each WEST assessment; if the GMS is referred to in the WEST report using a different GMS identifier, this is noted as well.

4.1.1. Red River:

- **RE01** - Farthest downstream GMS. Contains seven cross sections. Important monitoring GMS just downstream of all FMM Project features.
- **RE02** - Covers the area immediately upstream and downstream of the FMM Project’s Diversion Channel outlet. Contains ten cross sections. This GMS is separated into two separate GMSs with six cross sections in each GMS for geomorphic assessments after 2022.
- **RE03** - This GMS is located adjacent to Trollwood Park, just downstream of Edgewood Golf Course, and upstream of Broadway. Contains six cross sections.
- **RE04** - Located just downstream of Interstate 94, bounded on the west by Lindenwood Park in Fargo and Gooseberry Mound Park in Moorhead. Contains six cross sections.
- **RE05** - Located near Briarwood, ND. Contains six cross sections.

- **RE06** - This GMS is located just downstream of the Wild Rice River confluence. Contains six cross sections. It is noted that RE06 was defined in the WEST (2019) assessment to contain both the cross sections for this updated RE06 and the updated RE06A defined below.
- **RE06A** - This GMS is located just upstream of the Wild Rice River confluence. Contains six cross sections. It is noted that the cross sections for this GMS were contained within RE06 in the WEST (2019) assessment.
- **RE07** – Located downstream of the dam and just upstream of 110th Ave S in Fargo. Contains six cross sections.
- **RE08A** – Located one mile upstream of the FMM Project dam. Contains nine cross sections, including three most downstream cross sections that were part of RE08A.
- **RE09** - GMS is located in upper staging area. Contains six cross sections.
- **RE10** - This is the furthest upstream GMS and is located just downstream of Abercrombie, ND. Contains six cross sections. Not anticipated to be impacted by FMM Project operations and therefore serves as a reference reach.

4.1.2. Wild Rice River

- **WR01** – Most downstream Wild Rice River GMS upstream of its confluence with the Red River. Contains six cross sections.
- **WR02** - This GMS is located downstream of 100th Ave S. Contains six cross sections.
- **WR03** - Located downstream of the Wild Rice River dam. Contains six cross sections.
- **WR04** - Located within the staging area. Contains six cross sections.
- **WR05** - This GMS is located in the upper retention footprint. Contains six cross sections.
- **WR06** - Upstream of staging area footprint. Contains six cross sections.
- **WR07** - Located upstream of County Road 28. Contains six cross sections. Not anticipated to be impacted by FMM Project operations and therefore serves as a reference reach. The GMT should consider removing this GMS or WR08 from future assessments, as both serve as a reference reach.
- **WR08** - Located upstream of County Road 4. Contains seven cross sections. Not anticipated to be impacted by FMM Project operations and therefore serves as a reference reach. The GMT should consider removing this GMS or WR07 from future assessments, as both serve as a reference reach.

4.1.3. Sheyenne River

- **SH01** - Located upstream of the confluence with the Red River, this is the farthest downstream GMS on this river. Contains seven cross sections.
- **SH02** - Located between the Rush River's and Lower Rush River's confluences with the Sheyenne River. Contains six cross sections.
- **SH03** - Located just downstream of the Maple River confluence. Contains six cross sections.
- **SH04** - Located downstream of existing West Fargo Diversion. Contains six cross sections.
- **SH05** - Located in West Fargo upstream of the Main Avenue crossing and downstream of the existing West Fargo Diversion. Contains six cross sections.
- **SH06A** – Located near the 64th Avenue South crossing and downstream of the existing Horace to West Fargo Diversion. Contains six cross sections. Note that this GMS was not included in the WEST (2019) geomorphic assessment but it was included in the WEST (2012) assessment. Survey data was collected in this GMS by WEST in 2012 and by USACE in 2019.
- **SH06** - Located close to the USGS sediment monitoring site just downstream of Wall Street in Horace and downstream of the existing Horace to West Fargo Diversion. Contains six cross sections.
- **SH07** - Located just upstream of the FMM Project Diversion Channel and Sheyenne River Aqueduct. Contains eight cross sections.

- **SH08** - Furthest upstream Sheyenne River GMS. Contains six cross sections. Not anticipated to be impacted by FMM Project operations and therefore serves as a reference reach.
- No additional GMSs would be added. However, additional data collection efforts will be considered in the future to collect longitudinal profiles and video/photographic data.

4.1.4. Maple River

- **MA01** - Most downstream Maple River GMS located between the Maple River's confluence with the Sheyenne River and the Maple River Aqueduct. Contains a total of seven cross sections.
- **MA02** - Located just upstream of FMM Project Diversion Channel and Maple River Aqueduct. Contains six cross sections.
- **MA03** - Near Mapleton, this is the furthest upstream GMS on the Maple River. Contains six cross sections. Not anticipated to be impacted by FMM Project operations and therefore serves as a reference reach.
- No additional GMSs would be added. However, additional data collection efforts will be considered in the future to collect longitudinal profiles and video/photographic data.

4.1.5. Lower Rush River

- **LR01** - Located upstream of FMM Project Diversion Channel. Contains six cross sections. LR01 is the only GMS on the Lower Rush River. Not anticipated to be impacted by FMM Project operations and therefore serves as a reference reach.

4.1.6. Rush River

- **RU01** - Located upstream of FMM Project Diversion Channel. Contains seven cross sections. RU01 is the only GMS on the Rush River. Not anticipated to be impacted by FMM Project operations and therefore serves as a reference reach.

4.1.7. Wolverton Creek

- **WC01** – Downstream-most GMS located between 130th Ave S and 3rd St S. GMS was not surveyed as part of the WEST effort in 2019 but was surveyed as part of the WEST efforts in 2012 and 2021. Contains six cross sections.
- **WC02** - Located downstream of Highway 75 and upstream of 130th Ave S. GMS was not surveyed as part of the WEST effort in 2019 but was surveyed as part of the WEST efforts in 2012 and 2021. Contains six cross sections.
- **WC03** – Located just downstream of the FMM Project dam. Contains six cross sections.
- **WC04** – Located upstream of the FMM Project dam. Contains six cross sections. Not anticipated to be impacted by FMM Project operations and therefore serves as a reference reach.

4.1.8. Buffalo River

- **BU01** - Only GMS located on the Buffalo River located on the western edge of Georgetown, Minnesota, downstream of Mason Street. GMS was not surveyed as part of the WEST effort in 2019 but was surveyed as part of the WEST efforts in 2012 and 2021. Contains six cross sections.

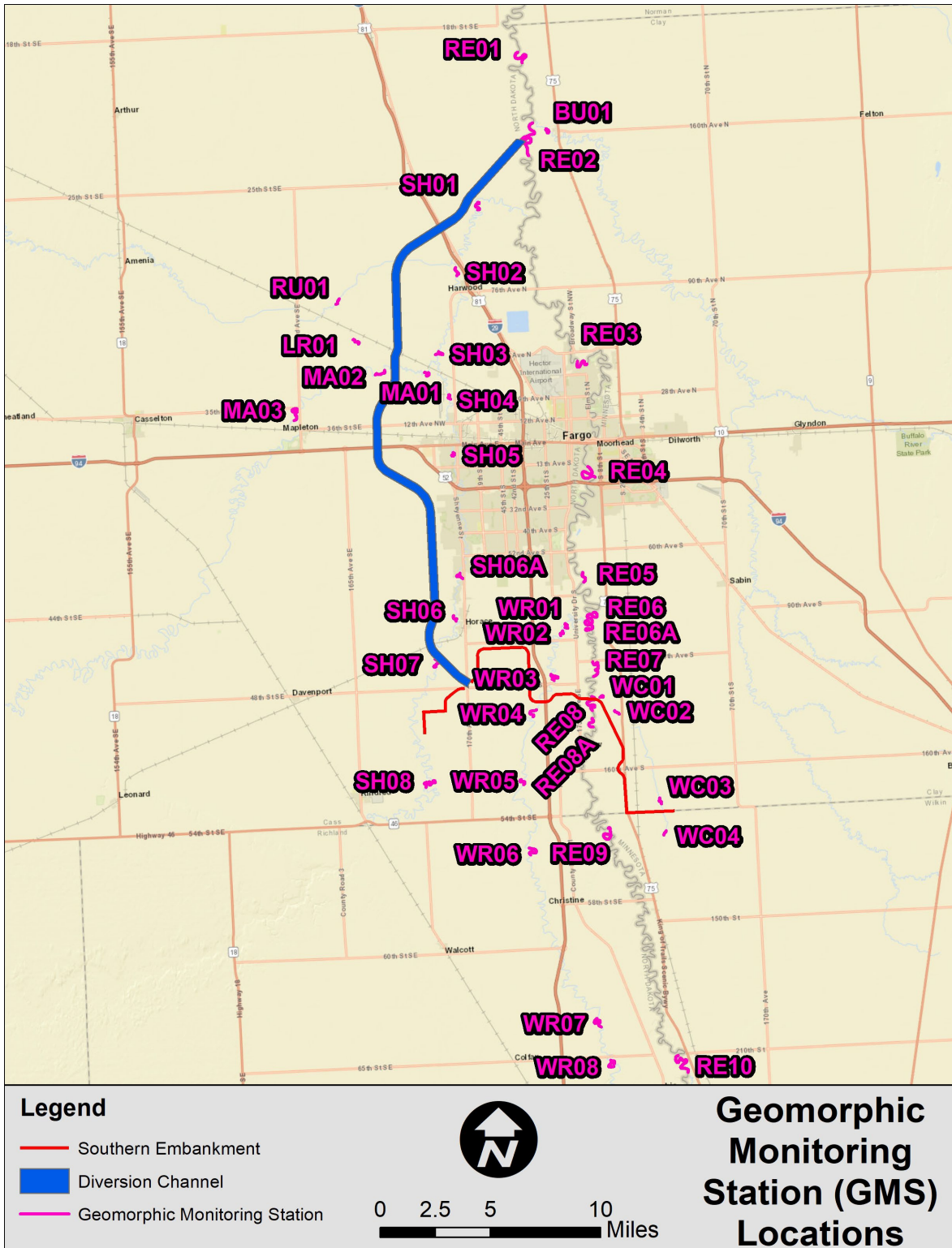

Figure 1. Geomorphic Monitoring Station Locations.

- NOTE: 1) RE02 is divided into two GMS, one on each side of Diversion Channel Outlet.
 2) Move the three most upstream cross-sections in RE-08 into RE-08A, delete RE-08.

Table 4-1: FMM Project Geomorphic Monitoring Station Cross Section Count

#	GMS	Cross Sections
1	RE01	7
2	RE02 & RE02A	12
3	RE03	6
4	RE04	6
5	RE05	6
6	RE06	6
7	RE06A	6
8	RE07	6
10	RE08A	9
11	RE09	6
12	RE10	6
13	WR01	6
14	WR02	6
15	WR03	6
16	WR04	6
17	WR05	6
18	WR06	6
19	WR07	6
20	WR08	7
21	SH01	7
22	SH02	6
23	SH03	6
24	SH04	6
25	SH05	6
26	SH06	6
27	SH06A	6
28	SH07	8
29	SH08	6
30	MA01	7
31	MA02	6
32	MA03	6
33	LR01	6
34	RU01	7
35	WC01	6
36	WC02	6
37	WC03	6
38	WC04	6
39	BU01	6
<i>TOTAL</i>		<i>245</i>

Table 4-2: Geomorphic Monitoring Station Changes throughout Pre-FMM Project Geomorphic Assessments by WEST

GMS	2012 WEST Assessment	2019 WEST Assessment	2021 WEST Assessment
RE01	Referred to as Red River – 1 – 410.65	Part of assessment	Part of assessment
RE02	Referred to as Red River – 2 – 419.14	Part of assessment	Part of assessment
RE03	Referred to as Red River – 3 – 440.57	Part of assessment	Part of assessment
RE04	Referred to as Red River – 4 – 452.52	Part of assessment	Part of assessment
RE05	Referred to as Red River – 5 – 463.56	Part of assessment	Part of assessment
RE06	Not part of assessment	Included both RE06 and RE06A under the heading of RE06 in this assessment	Part of assessment
RE06A	Referred to as Red River – 6 – 470.23		Part of assessment
RE07	Not part of assessment	Part of assessment	Part of assessment
RE08	Not part of assessment	Part of assessment	Part of assessment
RE08A	Not part of assessment	Not part of assessment	Part of assessment
RE09	Referred to as Red River – 7 – 492.47	Part of assessment	Part of assessment
RE10	Referred to as Red River – 8 – 521.18	Part of assessment	Part of assessment
WR01	Referred to as Wild Rice River – 1 – 3.01	Part of assessment	Part of assessment
WR02	Referred to as Wild Rice River – 2 – 4.23	Part of assessment	Part of assessment
WR03	Not part of assessment	Part of assessment	Part of assessment
WR04	Not part of assessment	Part of assessment	Part of assessment
WR05	Referred to as Wild Rice River – 3 – 17.52	Part of assessment	Part of assessment
WR06	Referred to as Wild Rice River – 4 – 22.94	Part of assessment	Part of assessment
WR07	Referred to as Wild Rice River – 5 – 38.49	Part of assessment	Part of assessment
WR08	Referred to as Wild Rice River – 6 – 42.36	Part of assessment	Part of assessment
SH01	Referred to as Sheyenne River – 1 – 4.20	Part of assessment	Part of assessment
SH02	Referred to as Sheyenne River – 2 – 11.56	Part of assessment	Part of assessment
SH03	Referred to as Sheyenne River – 3 – 18.15	Part of assessment	Part of assessment
SH04	Referred to as Sheyenne River – 4 – 22.27	Part of assessment	Part of assessment
SH05	Referred to as Sheyenne River – 5 – 26.47	Part of assessment	Part of assessment
SH06	Not part of assessment	Part of assessment	Part of assessment
SH06A	Referred to as Sheyenne River – 6 – 35.82	Not part of assessment; survey data collected by USACE in summer 2019 for use in future assessments	Part of assessment

GMS	2012 WEST Assessment	2019 WEST Assessment	2021 WEST Assessment
SH07	Referred to as Sheyenne River – 7 – 43.27	Part of assessment	Part of assessment
SH08	Referred to as Sheyenne River – 8 – 55.75	Part of assessment	Part of assessment
MA01	Referred to as Maple River – 1 – 0.78	Part of assessment	Part of assessment
MA02	Not part of assessment	Part of assessment	Part of assessment
MA03	Referred to as Maple River – 2 – 11.39	Part of assessment	Part of assessment
LR01	Referred to as Lower Rush River – 2 – 6.03	Part of assessment	Part of assessment
RU01	Referred to as Rush River – 2 – 6.15	Part of assessment	Part of assessment
WC01	Referred to as Wolverton Creek – 1 – 0.64	Not part of assessment	Part of assessment
WC02	Referred to as Wolverton Creek – 2 – 2.02	Not part of assessment	Part of assessment
WC03	Not part of assessment	Not part of assessment	Part of assessment
WC04	Not part of assessment	Not part of assessment	Part of assessment
BU01	Referred to as Buffalo River – 1 – 1.19	Not part of assessment	Part of assessment

4.2. Geomorphic Monitoring Stations Recommended for Post-FMM Project

This section describes an additional 3 GMSs with a total of 18 monitoring cross sections along the Diversion Channel that are recommended for post-FMM Project monitoring. Monitoring of these GMSs will inform sediment delivery from watercourses intersected by the Diversion Channel and will also inform whether native material from the Diversion Channel is being eroded and potentially delivered to the Red River. All 3 GMSs should include three pool and three riffle cross sections, and a longitudinal profile that follows the thalweg of the meandered low flow channel within the Diversion Channel.

4.2.1. Diversion Channel

- **DC01** – Downstream-most Diversion Channel GMS. Recommended to be located above confluence with Red River and downstream of Rush River and Highway 29.
- **DC02** - Middle Diversion Channel GMS. Recommended to be located just below Drain 14, downstream of Interstate 94, and upstream of the Maple River aqueduct.
- **DC03** - Upstream-most Diversion Channel GMS. Recommended to span both upstream and downstream of the Sheyenne River aqueduct.

The GMT should also consider adding GMSs immediately downstream of the Sheyenne River aqueduct, immediately downstream of the Maple River aqueduct, upstream of the Rush River inlet to the Diversion Channel, and upstream of the Lower Rush River inlet to the Diversion Channel. These are all areas not currently being monitored but were identified as locations that may experience changes in Section 3.2.

5. GEOMORPHIC MONITORING METHODS

Monitoring for geomorphic changes in the FMM Project vicinity generally follows the Before-After Control-Impact (BACI) (Smith, 2002) accounting method. The BACI sampling framework compares the *before* (pre-FMM Project condition using baseline data) condition to the *after* (post-FMM Project) condition of the area. To account for changes that may occur within the system that are natural changes, the area of impact is compared to another area, which is referred to as a reference site. This is a site that is not expected to be impacted by FMM Project operations but is within close proximity of the FMM Project components and is representative of the reach/site in which changes may be observed due to the FMM Project. To establish baseline conditions, sampling is carried out on a number of occasions before FMM Project operation and a number of occasions following. The sampling design has incorporated BACI methods by recommending sampling areas both inside and outside the potential impact areas. Sampling has occurred three times before FMM Project construction and will occur for a minimum of three times after FMM Project construction as well. This approach allows for comparisons for assessing if an impact occurs.

The following sections describe the monitoring efforts that are recommended for all FMM Project geomorphic assessments. The Scope of Work that outlined the WEST (2021) work effort, developed and approved by the GMT, is included as Appendix A and is the general recommended approach for any future geomorphic monitoring effort.

5.1. Field Data Collection

Field-collected data is a core component of this GMP. Pre-FMM Project data has been collected in 2010/2011, 2018, and 2020 (it is noted that longitudinal profiles are only available for the Red River for 2010/2011). The following sections list specific types of field data that has been and is recommended to continue to be collected as part of each geomorphic assessment.

5.1.1. Cross Sections

Collection of data at cross sections is an important GMP component. Each GMS is comprised of permanent cross sections that allow for replicate data collection to evaluate whether the stream is aggrading, degrading, depositing, or eroding laterally at a specific location. The end of each cross section has a permanent monument that has been installed at or below the existing ground grade to assist in the collection of replicate cross sections. Pre-FMM Project cross section data were collected and are documented in the WEST reports (2012, 2019, and 2021). The WEST reports contain ArcGIS shapefiles and maps noting the location of each cross section. Post-FMM Project cross-sectional surveys shall try to survey the exact locations of the WEST cross sections to allow for appropriate comparisons. The GMT should also leverage any other bathymetric data collected in the FMM Project vicinity, as available. The non-Federal project sponsors have already acquired property easements to allow for geomorphic assessments for a number of the properties covering the GMS locations and are in the process of obtaining the easements for the remaining locations. All easements are anticipated to be obtained by 2022 or 2023.

In addition to collecting cross-sectional overbank and bathymetric survey data at each cross section, the following tasks shall also be conducted:

- Field-stake points corresponding to top-of-bank elevation (channel bank), bankfull elevation (only if there are obvious changes from previously observed bank conditions), and water surface elevation at time of field observation, both along a straight line of sight trajectory from monument end to monument end for each cross section as well as along a “hydraulic modeling” trajectory. Extend geomorphic investigation beyond the top of bank to capture the riparian area and possible overbank deposition, slumping, vegetation surveys, etc. using field stakes indicating needed survey extent.
- Make a qualitative description of riparian vegetation types and how that would impact bank stability.
- Estimate percentage of banks slumping within each GMS based on field observations.
- Document any erosion or deposition features and significant sources of sediment.
- Look for, identify, and document contributing factors (e.g., land use changes, obvious drainage changes, etc.) other than those due to the FMM Project that may be affecting the channel morphology and stability since the most recent geomorphic assessment.
- Obtain field data needed for Rosgen (2006) Level II (all worksheets) and Level III (only worksheets 3-1, 3-5, 3-6, and 3-10).
- Continue collecting photos at long-term photo stations for monitoring change at each cross section to add to the electronic photographic record of field investigations. Take photos upstream, downstream, and of both banks; include the entire channel cross-section with a vertical survey rod in the frame. If possible, show a survey team member pointing to the bankfull elevation. Photographs of a survey team member collecting the sample shall also be taken. Use a wide-angle lens to show the relative extent of floodplain or confinement on both sides of the channel. These are complimentary to the cross section measurements and provide additional

5.1.2. Longitudinal Profiles

Longitudinal profiles collect bed topography data in the down-channel direction and provide additional points to capture changes in the thalweg and channel slope that might otherwise be missed between the monumented cross sections and is a cost effective way of capturing that data. Longitudinal profiles could be sampled with acoustic Doppler current profilers coupled with GPS-grade survey gear covering multiple paths (following the thalweg or in the case of deeper water using a zig-zag pattern or point cloud sampling approach from which the thalweg could be picked out of). It is critical that horizontal and vertical control be established and be the same as for the cross sections and other monitoring efforts.

For the purposes of this GMP, longitudinal profiles are collected from the upstream most cross section to the downstream most cross section for each of the GMSs listed. If additional bathymetric data is collected in the FMM Project vicinity, this data should be leveraged as possible.

5.1.3. Sediment Sampling

Sediment sampling related to the geomorphology of rivers is conducted in the stream bed, bars, banks, and overbanks. Pre-FMM Project stream bed, bar, bank, and overbank samples were collected for each GMS by WEST and are documented in the 2012, 2019, and 2021 reports. For post-FMM Project sampling, it is recommended that stream bed, bar, bank, and overbank samples be collected for any new GMS. Post-FMM Project sediment sampling shall only occur in any GMS in which significant sediment type or size changes are observed.

5.1.4. Rosgen (2006) Assessments

Rosgen Level II assessments have been conducted for each of the WEST (2012, 2019, and 2021)

assessments and shall continue to be conducted. Data shall also be collected for Rosgen Level III worksheets 3-1, 3-5, 3-6, and 3-10 to help track the changes in the system over time.

5.2. Hydrology Assessment

USGS gages provide a long-term record of stage-discharge rating curves. Changes in stage for the same discharge can be used as an indicator of channel aggradation or degradation. As part of post-FMM Project hydrology assessments, it is recommended that the geomorphic assessment team obtain stage- discharge rating curve data from the USGS and update the specific gage analysis for each gage within the FMM study area to analyze gage changes over time working from the WEST (2021) (or subsequent) analysis forward.

5.3. Stability Analysis using Survey Data

Field-collected survey data allows for direct, repeatable comparisons of channel geometry at a specific location as well as along longitudinal profiles over time. As part of any future survey data-based stability analysis, the following tasks are recommended:

- Evaluate changes in surveyed cross section geometry for all historic data reported in WEST (2021) and all subsequent survey data. The data shall be summarized electronically in a spreadsheet listing the station and elevation information (in the Project datum) for each cross section. The data shall also be plotted in a cross-sectional format to show any changes compared to all available historic data.
- Evaluate surveyed longitudinal profile. The data shall be summarized electronically in a spreadsheet listing the station and elevation information (in the Project datum) for each GMS. The data shall also be plotted in a profile format so changes in bed elevation along the profile can be viewed and compared to all available historic data.

5.4. Stability Analysis using Aerial Imagery

Aerial imagery is useful for observing changes and to provide early information highlighting possible changes. It is especially useful for capturing surface changes during and after major flood events that might not be recognizable at the ground level. The primary goal of the aerial imagery analysis in this GMP is to locate areas where obvious lateral shifts in the bank location or vegetation type/density have occurred compared to previous data sets and to flag these areas for further investigation. Pre-FMM Project high-resolution aerial imagery has been collected by the FMM Project's non-Federal sponsors every three years beginning in 2008 and spanning through 2020. Post-FMM Project imagery shall also be collected by the FMM Project's non-Federal sponsors. This imagery collection ideally will occur when water levels in the FMM Project vicinity are within their banks to allow for accurate bank delineation to occur.

Aerial imagery has been historically collected every three years and used to capture trends in the land surface, including use and observations of impacts from the Project and other causes. During construction and post-construction, the intervals should be conducted to occur in the autumn months before scheduled geomorphological field assessments (scheduled every 5 years) to inform the assessment scope of work. The aerial surveys could continue to be conducted every three years as determined by the local agencies which use the aerial information for other purposes.

As part of post-FMM Project stability analyses using aerial imagery, the following tasks are

recommended:

- Delineate bank lines throughout the project area using the protocols established in Section 7.1.4.
- Locate, measure, and document where lateral shifts in the bank line locations have occurred compared to those locations identified in the WEST (2021) report or other subsequent assessments. The WEST (2021) report contains the delineated bank line locations in ArcGIS shapefiles and/or geodatabases.
- Determine sinuosity, channel (meander) migration and erosion rates, and meander amplitude and frequency.
- Evaluate trends in sedimentary features (in-stream sediment bars), changes in large woody debris (LWD), and changes in riparian vegetation type using the aerial imagery.
- Evaluate the degree of incision. If channel is incised, then the influence of contained flow may increase channel erosion.

5.4.1. Use of Video Footage to Document Changes in Geomorphology

The Corps is working with WEST to evaluate video footage methods to document unstable banks, erosion, deposition, and other changes that could occur due to the Project or other items. The study will consider technical and economic factors related to the use of drone-mounted LiDAR, multiple cameras mounted on boats, and other methods. Following the study, the results shall be presented to the AMT for further consideration to improve data collection.

6. TRIGGERS AND RESPONSES

The Red River and tributaries are dynamic river systems and are expected to show movement of their mobile boundaries. Sites that already show changes in response to existing processes need to be monitored as well as sites that are expected to show change in response to the FMM Project construction and operation. Reference sites outside of the FMM Project impact area will also be monitored to help establish rates of change and natural variability in response to drivers other than the FMM Project. Getting reference and pre-FMM Project data will help establish reference ranges of change rather than singular thresholds for delineating accelerated change outside of the range of norms. A first step for evaluating the system and rates of change is to use pre-FMM Project data collected as part of the WEST (2012, 2019, and 2021) assessments to determine observed types of change and what types and scales of change would trigger a need for action.

6.1. Triggers

Parameters for defining triggers warranting additional action were discussed with the AMT and GMT during a series of meetings spanning April through June 2021. Three variables were identified for use as triggers during the discussions: Entrenchment Ratio, Bank Height Ratio, and Aerial Image-Derived Bank Line Location. The use of the Rosgen Bank Erosion Hazard Index (BEHI) / Near-Bank Stress (NBS) ratings was considered by the GMT for use as a threshold but was ultimately dismissed because its use may not be entirely applicable to the Red River system and because the aerial image-derived bank line location approach would serve as a similar trigger. Additionally, measured change in bankfull cross-sectional area was also considered for use as a threshold but was ultimately dismissed because this data is a main component in the Entrenchment Ratio and Bank Height Ratio calculations and because this type of approach does not appear to have been used in practice or discussed in literature.

It is noted that as part of the adaptive management and monitoring component of this GMP, the GMT should consider and provide recommendations to the AMT whether triggers should be added, adjusted, or removed based on additional data, information, and/or observed detrimental impacts that are not covered by the triggers established herein.

6.1.1. Entrenchment Ratio

According to Rosgen (1994), a stream's Entrenchment Ratio is a quantitative expression of the "interrelationship of the stream to its valley and/or landform features" and "distinguishes whether the flat adjacent to the channel is a frequent floodplain, a terrace (abandoned floodplain) or is outside of a flood-prone area." Rosgen (1994) defined the Entrenchment Ratio as the flood-prone width divided by the bankfull width, with the flood-prone width "defined as the width measured at an elevation which is determined at twice the maximum bankfull depth." Additionally, Rosgen (1994) stated that "field observation shows this (flood-prone) elevation to be a frequent flood (50 year return period) or less, rather than a rare flood elevation." Figure 6-1 shows an example of these variables.

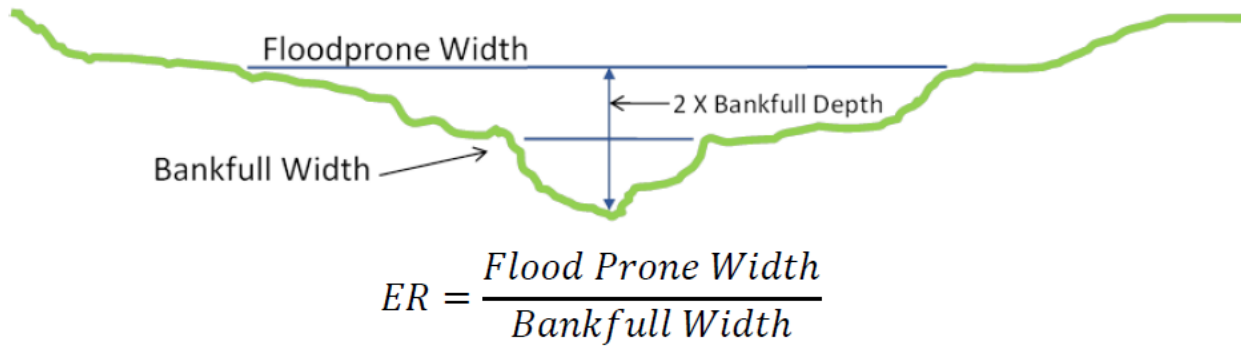

Figure 6-1: Entrenchment Ratio Example Graphic

The development of the Entrenchment Ratio action triggers for this AMMP relied on triggers established in literature as well as data collected during the pre-FMM Project geomorphic assessments.

The Minnesota Stream Quantification Tool (MN SQT) Steering Committee developed a scientific support document for the MN SQT, in which Entrenchment Ratio performance standards are provided.

According to the scientific support document, an Entrenchment Ratio of greater than 2.2 is considered to indicate a fully functioning stream for the Rosgen C and E stream types, which according to the WEST (2019) report are the Rosgen stream classifications for all of the geomorphic monitoring stations within the FMM Project study area. Therefore, the first step in the Entrenchment Ratio trigger establishment considered whether a stream that previously had an Entrenchment Ratio of greater than 2.2 transitioned to a stream with an Entrenchment Ratio of 2.2 or less.

The second part of the trigger establishment evaluated the Entrenchment Ratios determined using the datasets collected by WEST in 2012 and 2019, with the methodology that was followed in calculating these Entrenchment Ratios defined in Section 7.1. The observed range of Entrenchment Ratios within both datasets for each stream is summarized in Table 6-1. As shown in the table, most Entrenchment Ratios far exceed the value of 2.2, which indicates that most of the streams are considered fully functioning, primarily due to the well-developed floodplains prevalent in the FMM Project vicinity.

Table 6-1: Observed Entrenchment Ratios by Stream

Stream	Entrenchment Ratio
Buffalo River	2.8 – 3.0
Lower Rush River	6.4 – 8.1
Maple River	5.3 – 11.1
Red River	3.8 – 10.3
Rush River	17.0 – 26.9
Sheyenne River	7.5 – 14.0
Wolverton Creek	2.0 – 5.0
Wild Rice River	2.6 – 8.0

In defining an appropriate trigger based on the observed Entrenchment Ratios, it was deemed appropriate and consistent with the Rosgen (1994) paper to allow the trigger to be 0.2 Entrenchment Ratio units less than the minimum observed Entrenchment Ratio value. Therefore, this second step in the Entrenchment Ratio trigger establishment considered the lowest observed Entrenchment Ratio for each stream, then subtracted 0.2 off that value for each stream.

The final trigger establishment was to set the trigger for each stream at the lesser of either 2.2 (based on the MN SQT) or the lowest observed Entrenchment Ratio minus 0.2, with the trigger values displayed in Table 6-2.

Table 6-2: Entrenchment Ratio Action Triggers by Stream

Stream	Action Trigger
Buffalo River	<2.3
Lower Rush River	<2.3
Maple River	<2.3
Red River	<2.3
Rush River	<2.3
Sheyenne River	<2.3
Wolverton Creek	<1.8
Wild Rice River	<2.3

It is noted that these Entrenchment Ratio action triggers will be re-evaluated by the AMT and GMT if any additional pre-FMM Project geomorphic assessments are completed (which would only happen if a flood occurs in the pre-FMM Project timeframe). The methodology that shall be used to calculate Entrenchment Ratios using any additional pre-FMM Project datasets for the purposes of supplementing and/or adjusting the action triggers is outlined in Section 7.1.

In the event an Entrenchment Ratio trigger is exceeded, the GMT and AMT shall consider whether the reference reaches have also shown changes in the Entrenchment Ratio when working to establish whether the Entrenchment Ratio trigger exceedance is attributable to the FMM Project construction.

It is also noted that Wolverton Creek sites WC03 and WC04 were part of a large stream restoration project completed by the Buffalo-Red River Watershed District between 2018 and 2020. The data collected as part of the 2021 effort was collected after the restoration project was completed in these portions of Wolverton Creek. The GMT and AMT should take this into consideration when evaluating any Entrenchment Ratio triggers on Wolverton Creek.

The Corps is working with WEST to develop recommendations to evaluate changes to the action triggers that would consider either values above those recorded in the three intervals of the baseline data at each location or a set percentage above the last measured change for each GMS. The evaluation will consider causes and impacts of changes.

The Corps is working with WEST to develop recommendations for Entrenchment Ratio action triggers by GMS instead of by stream.

The Corps is working with WEST to develop recommendations for Entrenchment Ratio

investigation triggers by GMS instead of by stream. The Entrenchment Ratio investigation triggers would be based upon a percent difference to the historically observed values. The investigation triggers would be set to 5 percent, 10 percent, or 15 percent increments based upon the maximum differences that have been observed for each GMS.

6.1.2. Bank Height Ratio

According to the MN SQT, a stream's Bank Height Ratio "is a measure of channel incision and indicates whether a stream is or is not connected to an active floodplain or bankfull bench." Rosgen (1996) defined the Bank Height Ratio as "the depth from the top of the low bank to the thalweg divided by the depth from the bankfull elevation to the thalweg." Figure 6-2 shows an example of these variables.

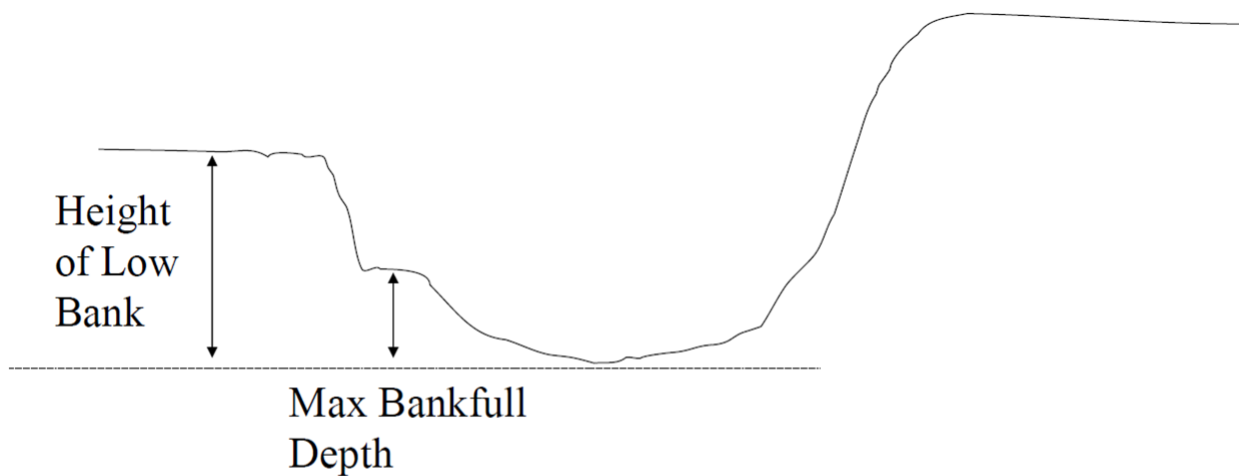

$$BHR = \frac{\text{Low Bank Height}}{D_{max}}$$

Figure 6-2: Bank Height Ratio Example Graphic

Similar to the Entrenchment Ratio action triggers, the development of the Bank Height Ratio action triggers for this AMMP relied on triggers established in literature as well as data collected during the pre-FMM Project geomorphic assessments.

The Minnesota Stream Quantification Tool (MN SQT) Steering Committee developed a scientific support document for the MN SQT, in which Bank Height Ratio performance standards are provided. According to the scientific support document, a Bank Height Ratio of less than 1.3 is considered to indicate a fully functioning stream. Therefore, the first step in the Bank Height Ratio trigger establishment considered whether a stream that previously had an Bank Height Ratio of less than 1.3 transitioned to a stream with a Bank Height Ratio of 1.3 or greater.

The second part of the trigger establishment evaluated the Bank Height Ratios determined using the datasets collected by WEST in 2012 and 2019, with the methodology that was followed in calculating these Bank Height Ratios defined in Section 7.1. The observed range of Bank Height Ratios within both datasets for each stream is summarized in Table 6-3. The Bank Height Ratios

generally are in the fully functioning or partially functioning category, which indicates moderate levels of incision on a number of streams in the FMM Project vicinity.

Table 6-3: Observed Bank Height Ratios by Stream

Stream	Bank Height Ratio
Buffalo River	1.3 – 1.3
Lower Rush River	1.1 – 1.4
Maple River	1.0 – 1.2
Red River	1.0 – 1.3
Rush River	1.2 – 1.5
Sheyenne River	1.0 – 1.4
Wolverton Creek	0.8 – 2.1
Wild Rice River	0.9 – 1.3

In defining an appropriate trigger based on the observed Bank Height Ratios, it was deemed appropriate to allow the trigger to be 0.1 Bank Height Ratio units less than the minimum observed Bank Height Ratio value due to the fact that the Bank Height Ratio relies on rounding to the nearest 0.1 units. Therefore, this second step in the Bank Height Ratio trigger establishment considered the highest observed Bank Height Ratio for each stream, then added 0.1 to that value for each stream.

The final action trigger establishment was to set the trigger for each stream at the greater of either 1.2 (based on the MN SQT) or the highest observed Bank Height Ratio plus 0.1, with the trigger values displayed in Table 6-4.

Table 6-4: Bank Height Ratio Action Triggers by Stream

Stream	Action Trigger
Buffalo River	>1.4
Lower Rush River	>1.5
Maple River	>1.3
Red River	>1.4
Rush River	>1.6
Sheyenne River	>1.5
Wolverton Creek	>2.2
Wild Rice River	>1.4

It is noted that these Bank Height Ratio action triggers will be re-evaluated by the AMT and GMT if any additional pre-FMM Project geomorphic assessments are completed (which would only happen if a flood occurs in the pre-FMM Project timeframe). The methodology that shall be used to calculate Bank Height Ratios using any additional pre-FMM Project datasets for the purposes of supplementing and/or adjusting the action triggers is outlined in Section 7.1.

In the event a Bank Height Ratio trigger is exceeded, the GMT and AMT shall consider whether the reference reaches have also shown changes in the Bank Height Ratio when working to establish whether the Bank Height Ratio trigger exceedance is attributable to the FMM Project construction.

It is also noted that Wolverton Creek sites WC03 and WC04 were part of a large stream restoration project completed by the Buffalo-Red River Watershed District between 2018 and 2020. The data collected as part of the 2021 effort was collected after the restoration project was completed in these portions of Wolverton Creek. The GMT and AMT should take this into consideration when evaluating any Bank Height Ratio action triggers on Wolverton Creek.

The Corps is working with WEST to develop recommendations to evaluate changes to the action triggers that would consider either values above those recorded in the three intervals of the baseline data at each location or a set percentage above the last measured change for each GMS. The evaluation will consider causes and impacts of changes.

The Corps is working with WEST to develop recommendations to revise the methodology in this section of the GMP to use a fixed bankfull elevation for determining BHR and to develop a list of assumptions to check after each sampling event and after the third cycle of sampling.

The Corps is working with WEST to develop recommendations for BHR action triggers by GMS instead of by stream.

The BHR investigation triggers shall be $BHR+0.1$ for all sites. The Corps is working with WEST to develop investigation triggers for each GMS to monitor system changes.

6.1.3. Bank Line Location

Defining quantitative action triggers for aerial imagery-derived bank line movement is inherently difficult, as every stream naturally moves and adjusts its location in response to a variety of causes and because of the uncertainty in the bank line delineation process due a variety of factors such as differing water levels and delineator judgments. Pre-FMM Project geomorphic assessments have included the delineation of bank line locations using aerial imagery, with these delineations creating information that can be used to assess channel movement outside of the surveyed cross section locations. The WEST (2012) report delineated bank line locations spanning from 2010 to as early as 1939 for some streams in the study area. The WEST (2019) report delineated bank line locations spanning from 2018 to 2010. The WEST (2021) report includes re-delineated bank line locations using only high-resolution aerial imagery collected between 2008 and 2020 and using a larger scale (1:1,000 vs. 1:3,000 previously) during bank line delineation to determine bank line location changes more clearly.

Triggers that would require the GMT and AMT to take further action are listed below:

- In the event any member of the GMT or AMT receives complaints from the public stating that the FMM Project is causing increased bank line movements in areas not within the immediate vicinity of a monitored cross section, the GMT shall meet to evaluate the complaint and compare the observed bank line movement that resulted in the complaint against historically-observed movement within the same area. The GMT shall then provide a consensus-based response to the AMT stating the following:
 - Whether the GMT judges the observed bank line movement that resulted in the complaint to be inside or outside the range of natural variability for that reach of the stream
 - If outside the range of natural variability, whether the GMT judges the observed bank line movement to be the result of the FMM Project
 - If the result of the FMM Project, the recommended corrective action

- Post-FMM Project construction geomorphic assessments will evaluate bank line locations and any associated movement and apply judgment to highlight areas that may fall outside of normal ranges (referring to the WEST 2012, 2019, and 2021 reports as background). These areas shall be further investigated by the GMT. The GMT shall then provide a consensus-based response to the AMT stating the following:
 - Whether the GMT judges the observed bank line movement that resulted in the complaint to be inside or outside the range of natural variability for that reach of the stream
 - If outside the range of natural variability, whether the GMT judges the observed bank line movement to be the result of the FMM Project
 - If the result of the FMM Project, the recommended corrective action

The GMT and AMT shall consider whether the reference reaches have also shown changes in bank line locations when working to establish whether this trigger has been exceeded and whether the trigger exceedance is attributable to the FMM Project construction.

6.2. Trigger Exceedance Response

In the event any of the triggers identified in Section 6.1 are exceeded or if it is the GMT's judgment that other significant change is occurring throughout the system and is not being captured by the currently established triggers, the following process shall be followed by the GMT and the findings provided to the AMT within the timelines established in Section 8.

6.2.1. GMT Investigations

First, the GMT shall provide a recommendation to the AMT as to whether the trigger exceedance is attributable to the FMM Project and, if possible, to what degree. Probable and possible causes for the exceedances should be detailed with documented data by the GMT for the AMT. The GMT should evaluate aerial imagery, LiDAR data, hydrology records, and any other available data sources as part of the attribution effort. One important component of this effort is to evaluate the reference reaches that were unimpacted by FMM Project operations to see if those reaches are showing similar geomorphic patterns. If those reaches are not showing similar geomorphic trends, it is possible (though not certain) that the FMM Project is the primary driver of the trigger exceedance. It is possible that some trigger exceedances will be easily verifiable as being principally caused by the FMM project or some other driver, such as changes in land use, drainage patterns, or precipitation. There are a number of reasons for trigger exceedances that may not be in any way influenced by the FMM Project, including but not limited to hydrology change, sediment load change, stream slope change, land use change, and standard geomorphic responses to large flood events that may have occurred both with and without the FMM Project. It is also possible that trigger exceedances may have a mix of drivers contributing to the exceedance or that they may initially appear to be indeterminant. In the cases where identifying the relative impact of multiple drivers is challenging, the AMT and GMT should consider engaging third- party facilitation to help articulate important criteria for making recommendations and for identifying follow-up actions to ultimately reach a recommendation.

Second, if the GMT concludes that the trigger exceedances were fully or in part attributable to the FMM Project, the GMT shall provide a recommendation to the AMT as to whether the impact is detrimental from the stakeholder perspective. In this instance, stakeholders include (but are not limited to) local, state, and federal agencies as well as local landowners. An example of a

clearly detrimental impact is FMM Project-induced erosion that is threatening the stability of a bridge crossing.

Third, if the GMT concludes that the trigger exceedances were fully or in part attributable to the FMM Project and that the impacts are detrimental, the GMT shall provide one or more recommended corrective actions, commensurate with the detrimental level of impact and with the level of attribution to the FMM Project, for consideration to the AMT. A list of geomorphic issues grouped into themes that may be experienced in the FMM Project vicinity and a list of associated potential corrective actions is provided in Section 6.2.2.

The Corps is working with WEST to evaluate video footage methods to document unstable banks, erosion, deposition, and other changes that could occur due to the Project or other items. The study will consider technical and economic factors related to the use of drone-mounted LiDAR, multiple cameras mounted on boats, multi-beam sonar (especially along the Red River), and other methods. Following the study, the results shall be presented to the AMT for further consideration to improve data collection.

6.2.2. List of Themes and Potential Corrective Actions for GMT Consideration

Issues potentially requiring corrective actions can be grouped into themes related to the physical processes that cause them. This can be helpful in treating the root cause of a trigger exceedance rather than just the appearances or symptoms. Treating the symptom instead of the cause may simply result in the same impacts reoccurring over time if the causes remain untreated. Cause determination will require the GMT to thoughtfully analyze the data and use their combined experience and expertise to attribute the issue(s)/symptom(s) to the actual cause(s). It is important to note that streams adapt to some changes over time. Therefore, the GMT shall consider the current stream condition state in relation to its ongoing and evolving geometry before determining the recommended corrective action(s).

A list of themes of geomorphic-related issues and associated potential corrective actions is included in this Section to support early discussions and facilitate a more rapid response when the GMT is recommending that corrective actions are needed. This list is not considered to be all-inclusive or contain any of the specificity required for actual design or implement of the ideas and will be modified over time as new techniques and structural corrective measures are developed. Within the list are references to texts with more information and examples of actions already implemented in the region that can inform discussion. Extensive, expert work will be required to bring contextual ideas to meaningful application based on the specific and unique characteristics of each area being evaluated and what the AMT and GMT determine is beneficial.

Five documents are supplied as appendices B through F to this GMP that give a thorough description of stream bed and bank issues and corrective actions. The appendices are:

- B. Resource Sheet 1: Streambank Erosion and Restoration (Minnesota DNR)
- C. Resource Sheet 2: The Value and Use of Vegetation (Minnesota DNR)
- D. Stream Restoration: Toe Wood-Sod Mat (Minnesota DNR)
- E. Chapter 11 of National Engineering Handbook 654 (Natural Resources Conservation Service)
- F. Chapter 14 of National Engineering Handbook 654 (Natural Resources Conservation Service)

6.2.2.1. Theme: Increased Bank Erosion and/or Channel Migration Rate

All natural streams have meander patterns that gradually migrate in a downstream direction with time, which requires some degree of erosion and deposition. Locations with increased rates of bank erosion, meander migration, and meander pattern change have often been destabilized due to hydrologic and hydraulic changes and/or changes in vegetation. Bank erosion/collapse in one location can produce sediment that is transported and deposit in downstream reaches, thereby producing a shallower channel in those areas. This, in turn, can destabilize those banks as the river tries to widen to handle the flows, resulting in a feedback cycle of destabilization throughout a system.

One potential corrective action is to reduce the flow velocity near the eroding bank. This can be done through the staking of live cuttings of deep-rooted woody vegetation that naturally occurs within the Red River valley ecosystem or the planting of willows, shrubs, grasses, and rooted forbes, among other vegetation, as this vegetation can significantly lower near-bank velocities. An example of willow plantings is shown in Figure 6-3.



Figure 6-3: Willow Plantings on the Mississippi River

Another potential corrective action is to install toe wood with a sod mat along the bank toe. This stabilizes the bank toe with both the toe wood and with the dense sod mat vegetation. It also has the added benefit of providing aquatic and terrestrial habitat. Toe wood-sod mats are sometimes an additional practice to the restoration of bank vegetation while other times just bank restoration is needed. Figure 6-4 shows the toe wood-sod mat concept while Figure 6-5 shows project examples where this technique has been used.

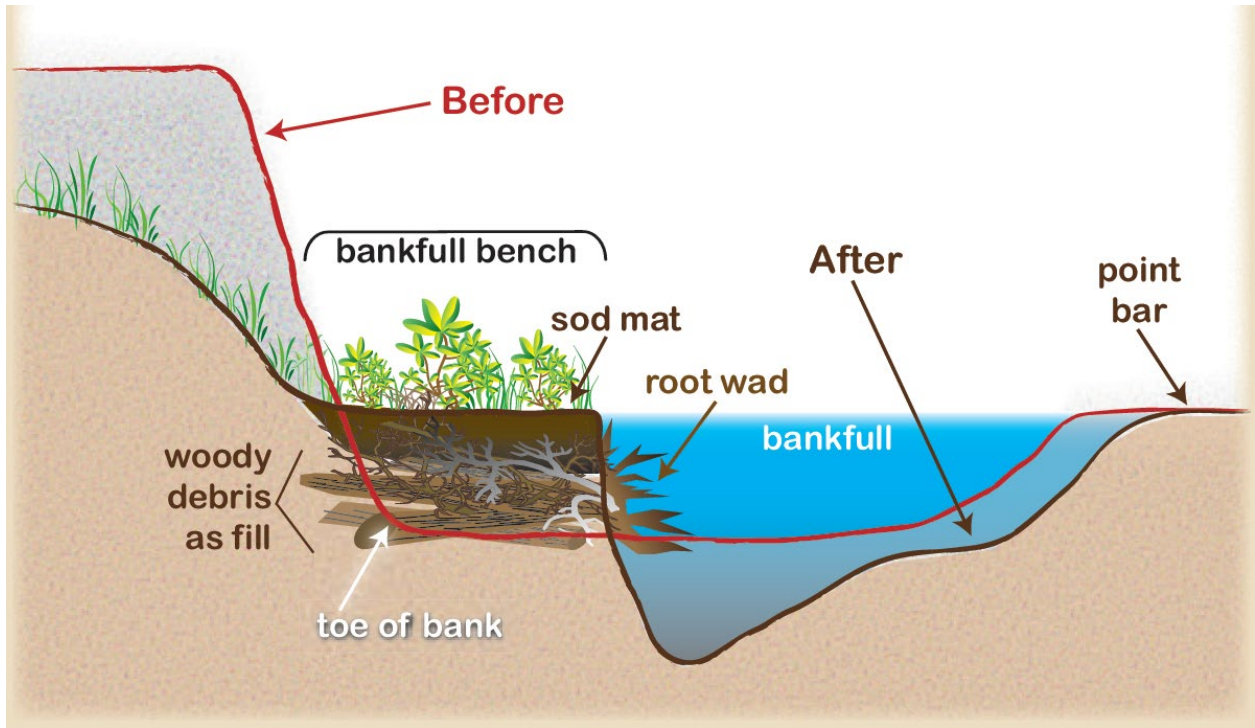

Figure 6-4: Toe Wood-Sod Mat Conceptual Example (source: Minnesota DNR)

Toe Wood-Sod Mat: Construction Examples

Spruce Creek	Buffalo River
 <p>Unstable bank encroaching on a picnic shelter. Toe of bank is eroding causing slumping and stream is overwide.</p>	 <p>Unstable bank and failing flood control dike protecting a mobile home park. The project started with the placement of woody debris and insertion of root wads.</p>
 <p>Construction of bankfull bench. A layer of woody debris and fill was placed along the bank toe then covered with live willow cuttings (in foreground).</p>	 <p>The completed woody debris layer with incorporated root wads. The upper bank was regraded with a more gentle slope.</p>
 <p>Collection of local dogwood and willow sod mats with very dense root mats.</p>	 <p>Dirt was added as fill and rooting material to the woody debris layer.</p>
 <p>Placement of final layer of sod mats on the constructed bench at bankfull elevation.</p>	 <p>Locally collected red-osier dogwood and willow sod mats were placed on the constructed bench at bankfull elevation.</p>
 <p>Finished bank stabilization project: Vegetated bankfull bench and a graded streambank protected with erosion control blankets.</p>	 <p>Project was completed with a vegetated bankfull bench and a re-graded upper bank seeded with native seed mix. New growth was thriving the next summer.</p>

Figure 6-5: Toe Wood-Sod Mat Construction Examples (source: Minnesota DNR)

A third potential corrective action is to construct J-hook vanes “designed to reduce bank erosion by reducing near-bank slope, velocity, velocity gradient, stream power and shear stress” (Rosgen, 2001). As flow passes over the length of the J-hook vane, the turbulence dissipates the flow energy and directs it toward the channel thalweg. Multiple J-hook vanes can be implemented, or toe-wood can be put between J-hook vanes on long outside bends. Figure 6-6 shows a generic plan, profile, and cross-sectional view of the J-hook vane.

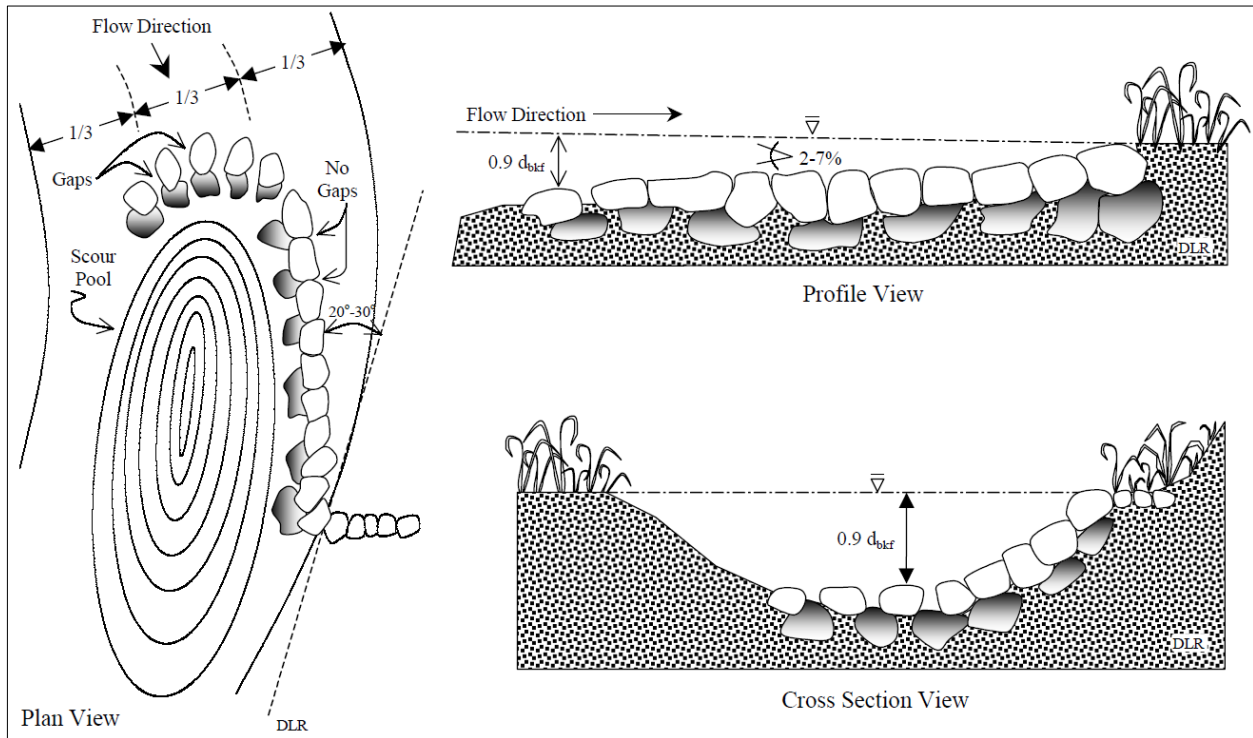

Figure 6-6: Generic J-Hook Vane Plan, Profile, and Cross-Sectional View Detail

A fourth potential corrective action for areas exhibiting bank erosion and channel migration is to add a longitudinal stone toe. This is similar to the toe wood-sod mat technique but has rock at the base of the toe. The use of rock over natural toe wood limits habitat for transitional aquatic species and transfers energy downstream, potentially resulting in erosion downstream of the corrective action area; therefore, this corrective action should primarily be considered only where the feature is protecting something of high value (roads, homes, etc.) where the tolerance to risk of failure is low. Figure 6-7 and Figure 6-8 show an example of a ‘longitudinal stone toe’ without bank re-shaping or creation of a berm behind the rock. The feature traps sediment from the eroding bank and produces a more stable slope that can be naturally vegetated. This corrective action is considered to be a last-resort remedy when infrastructure or residences are being threatened by erosion.



Figure 6-7: Longitudinal Stone Toe - Immediately After Construction (No Bank re-shaping)



Figure 6-8: Longitudinal Stone Toe – One Year After Construction (No Bank Re-shaping)

6.2.2.2. Theme: Channel Bed Degradation

Degrading channels are typically the result of either increases in reach discharge/velocity typically due to local drainage infrastructure or river crossings, reductions in sediment from upstream reaches or other sources (potentially due to perched crossings or, in the case of the FMM Project, the Sheyenne River and Maple River aqueducts), and/or increases in the river water surface slope due to the removal of downstream constrictions that increase the velocity and sediment transport capability of a reach.

Channel degradation results in deeper water along the banks, which can cause bank sloughing into the stream. Deeper and faster water along the banks makes them more likely to fail due to the undercutting of material along the bank toe.

One potential corrective action for river reaches that have experienced or are experiencing channel degradation is adding riffles to increase roughness and dissipate energy to prevent further degradation. An elliptically-shaped riffle can also be used to focus velocities away from the banks and direct them toward the pool portion of the stream. Generic plan, profile, and cross-sectional view details with generic dimensions are shown in Figure 6-9, Figure 6-10, and Figure 6-11, respectively.

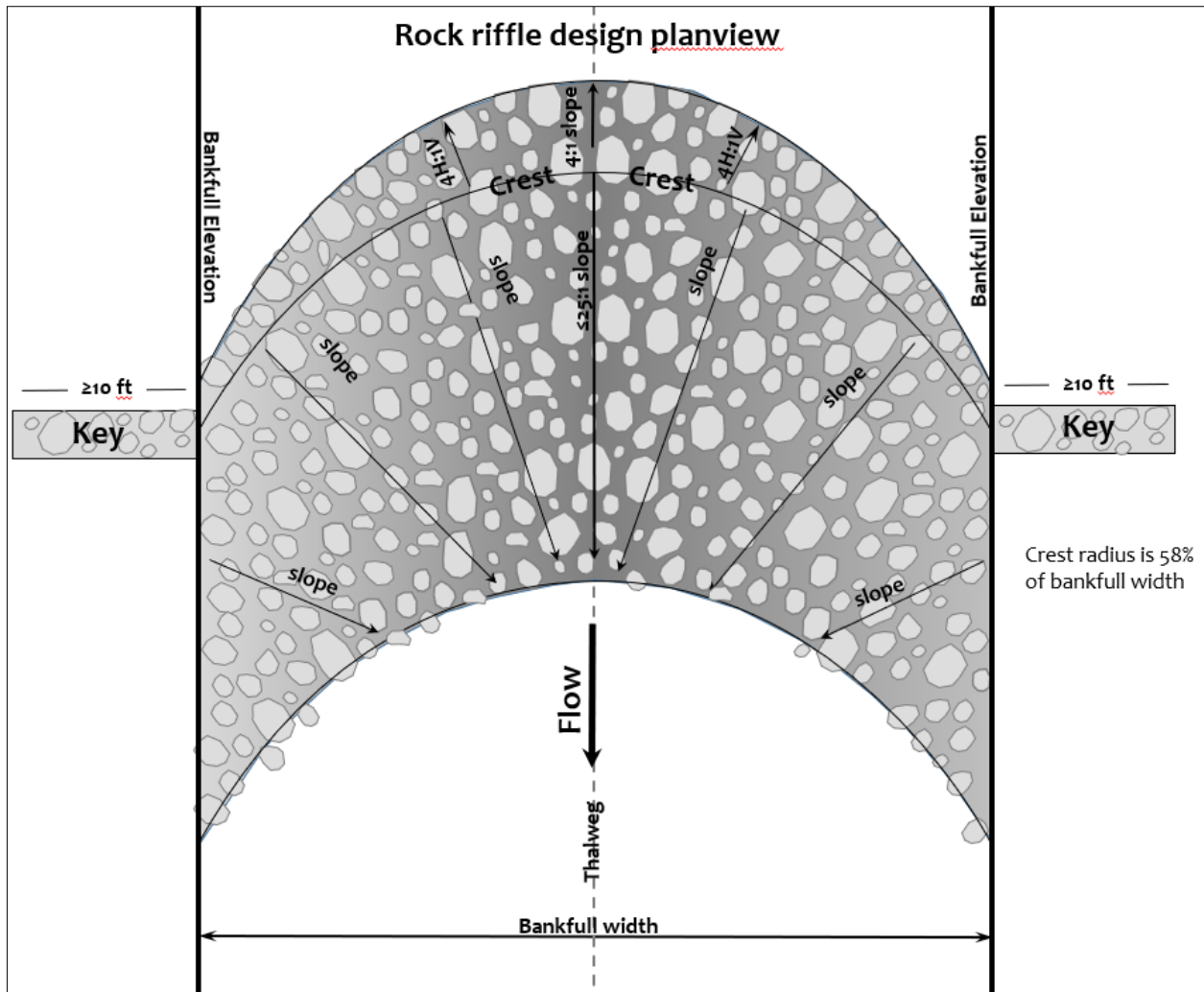

Figure 6-9: Generic Riffle Plan View Detail (Minnesota DNR)

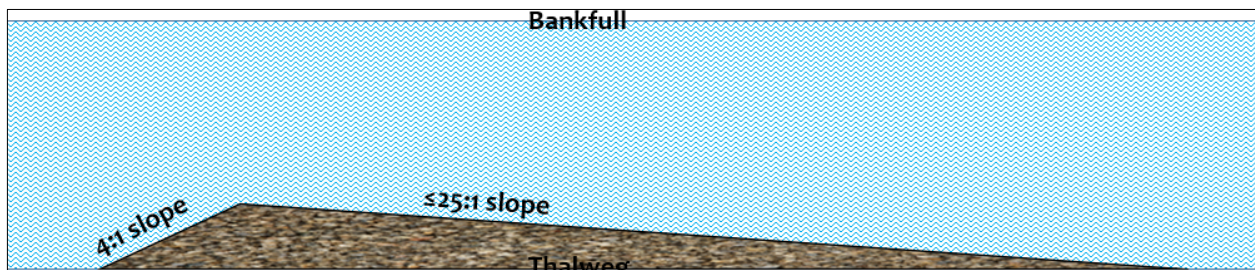

Figure 6-10: Generic Riffle Longitudinal Profile View Detail (Minnesota DNR)

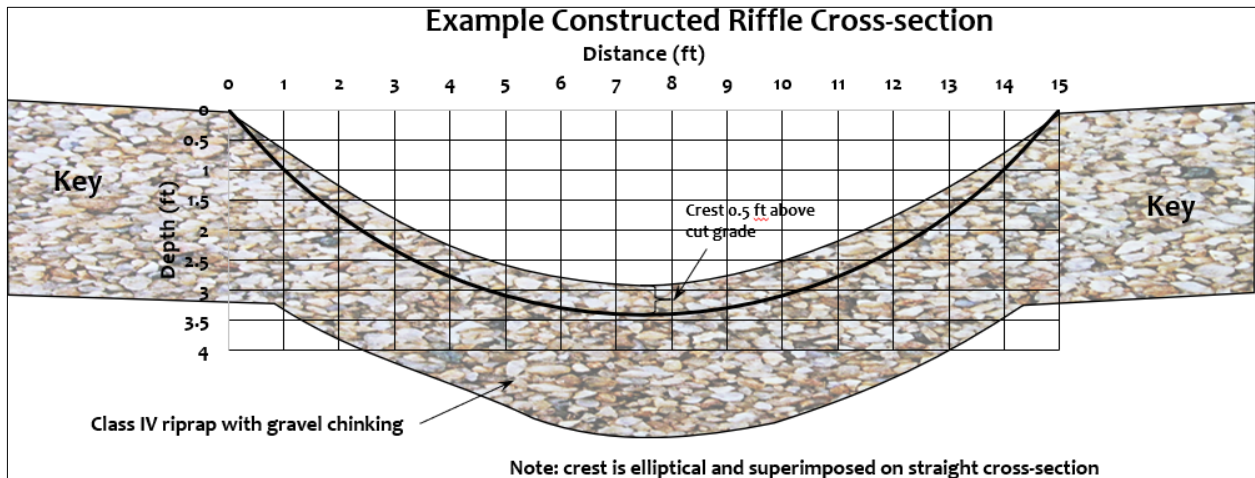

Figure 6-11: Generic Riffle Cross-Sectional View Detail (Minnesota DNR)

Another potential corrective action for a degrading stream bed is to add channel length through greater channel sinuosity and the addition of meanders, in concert with appropriate bed features with riffles at the cross-over and pools in the outside bends. Figure 6-12 shows a re-meandered section of Wolverton Creek near the town of Wolverton, Minnesota.



Figure 6-12: Re-meandered Segment of Wolverton Creek (source: Houston Engineering, Inc.)

A third method of reducing channel degradation is to lengthen the flood flow path of streams through the use of cut-off blockages. Toe wood-sod mat plugs (previously discussed in Section

6.2.2.1) and other similar woody debris/root wad configurations have been used to block cut-off areas along channels. It is noted that this method is most appropriate when there is enough land between the cut-off meanders. If the cut-off distance is too small, it has a high potential of cutting off again. Detailed and careful analysis by the GMT is necessary when considering this corrective action. Figure 6-13 shows a constructed toe wood-sod mat plug aimed at preventing channel cut-off.



Figure 6-13: Plug of Cut-Off Channel using Toe Wood-Sod Mat on the Pomme de Terre River in Minnesota

A fourth method to reduce bed degradation is the installation of J-hook vanes. The J-hook vane concept was previously discussed in Section 6.2.2.1.

6.2.2.3. Theme: Channel Bed Aggradation

Channel aggradation is oftentimes the result of a channel widened through bank erosion (thus reducing flow velocities and encouraging sediment deposition through the aggrading section), changes to upstream sediment supply (such as channel bank collapses and any resulting change in material sizes/characteristics), and/or flattening of the river surface slope due to a permanent downstream constriction (such as a new bridge or a road raise).

Bank collapse resulting in either a widened channel at the aggrading site or an increased sediment supply to the aggrading site can be addressed through the corrective actions discussed in Section 6.2.2.1.

A flattened water surface slope can be addressed by increasing the capacity of the river crossing resulting in the issue. It is noted that the Diversion Channel and associated infrastructure features are proactively being designed to minimize backwater increases and the associated flattened river water surface slopes, which minimizes the potential for these features to result in channel aggradation of the Rush River, Lower Rush River, Maple River, Sheyenne River, and the various drains and ditches intersected by the Diversion Channel.

6.2.2.4. Theme: Unstable Bank Slopes due to Sediment Deposition

In some situations, increases in overbank sediment deposition could increase the potential for slope stability problems. Unstable bank slopes can also result in slumping or collapse of riverbanks into the rivers. This is exacerbated in areas with a large amount of clay in floodplain sediments (such as the Red River and most of its tributaries) but can happen anywhere where the bank slope exceeds stable thresholds.

A potential corrective action is to increase slope stability by re-grading the channel banks in the affected area to slopes that are more stable and able to withstand any additional sediment deposition. Regrading the channel banks to create a more trapezoidal cross section is considered to be a last-resort remedy when infrastructure or residences are being threatened by the unstable bank slopes.

Another potential corrective action is to determine whether changes in the FMM Project's operating plan would decrease the sediment supply to the channel banks. Any changes to the operating plan would need to be balanced with the FMM Project's operational goals and if those goals result in additional environmental, economic, social, or cultural impacts beyond those disclosed in the FMM Project's NEPA documentation, additional corrective action would also be required to remedy those impacts. Any operational change shall be formally approved by the appropriate regulating agencies, including the US Army Corps of Engineers.

6.2.2.5. Theme: Localized Erosion

Erosion problems can also be locally based due to the presence of gated structures (such as the Red River Structure and Wild Rice River Structure), flow eddies, debris jams, bridges, elevated roadways, and other generally localized phenomena. A potential corrective action to localized erosion due to local hydraulics is to provide natural or non-natural erosion protection measures, such as large woody debris (natural) or riprap (non-natural). Other potential corrective actions for this theme could include modifications to or removal of the local cause of the erosion-inducing issue, such as reshaping of the channel banks or removal of debris jams.

7. PROTOCOLS AND STANDARDS

Rigor and consistency of data collection techniques and standards is critical for quality assurance and verifiable quantification of change. Discussing protocols and keeping them up to date with changing contractors and agency personnel is critical for ensuring accuracy and comparability of data sets over time. Therefore, reviewing and discussing sampling protocols shall occur in advance of scheduled field work, in the event of a flood event sampling situation, when there is a change in organizations/contractors conducting the sampling, and when there is a change in protocol or technologies. These discussions may include joint field visits of GMT members and the sampling organization/contractors to go over field methodologies and other protocols.

The following sections describe the protocols and data management/storage/exchange standards that shall be used. Any deviations to specific protocols developed for this GMP requires GMT and AMT approval, with text added to the GMP to describe this protocol change/deviation.

7.1. Protocols for Evaluating Geomorphic Triggers

This section prescribes the methods that shall be used for calculating/determining the Entrenchment Ratio, Bank Height Ratio, and bank line locations for the purpose of determining whether a trigger has been exceeded.

7.1.1. Bankfull Flow Rate Prescription

An accurate establishment of bankfull flows is integral to the calculations of Bank Height Ratio. WEST (2019) determined the bankfull flows for each geomorphic monitoring station by establishing bankfull elevations based on field observations then using a calibrated hydraulic model (HEC-RAS) to determine the flow needed to generate a water surface profile that equaled the field-observed bankfull elevations. The bankfull flows established as part of the WEST (2019) assessment for the Lower Rush River, Maple River, Red River, Rush River, Sheyenne River, and Wild Rice River were used to calculate Entrenchment Ratios and Bank Height Ratios using the survey data from the WEST 2012, 2019, and 2021 assessments. The bankfull flows established as part of the WEST (2021) assessment for the Buffalo River and Wolverton Creek were used to calculate Entrenchment Ratios and Bank Height Ratios using the survey data from the WEST 2012 and 2021 assessments (the 2019 assessment did not cover these streams). Table 7-1 summarizes the bankfull flows that shall be used for each geomorphic monitoring station. It is noted that the flow for SH05 was set to the same values for SH06 and SH04; however, this GMS is not actually connected to the rest of the Sheyenne River as it is protected by the Sheyenne River Flood Control Project. The Sheyenne River mitigation project that will be completed once the FMM Project becomes operational will allow flow to flow through SH05 again naturally. The calculations for the Entrenchment Ratio and Bank Height Ratio variables were completed using hydraulic model settings for the pre-FMM Project conditions with the Sheyenne River Flood Control Project that produced bankfull water surface elevations of approximately 896.7 feet in SH05 in the WEST (2019) hydraulic model. It is recommended that the GMT re-evaluate this flow and determine an appropriate bankfull flow for post-FMM Project calculations in SH05.

Table 7-1: Bankfull Flows for Use in Entrenchment Ratio and Bank Height Ratio Calculations

GMS	Bankfull Flow (cfs)	GMS	Bankfull Flow (cfs)	GMS	Bankfull Flow (cfs)
BU01	800	RE08	2,500	SH08	1,600
LR01	135	RE08A	2,500	WC01	150
MA01	1,050	RE09	2,500	WC02	145
MA02	1,050	RE10	2,300	WC03	30
MA03	1,050	RU01	200	WC04	25
RE01	5,000	SH01	2,800	WR01	1,000
RE02	5,000	SH02	2,700	WR02	1,000
RE03	3,800	SH03	2,600	WR03	850
RE04	3,800	SH04	1,500	WR04	825
RE05	3,800	SH05	750^	WR05	800
RE06	3,800	SH06A	1,500	WR06	775
RE06A	2,800	SH06	1,500	WR07	750
RE07	2,800	SH07	1,600	WR08	750

^See text above regarding Sheyenne River Flood Control Project influence in SH05

To validate the selection of the bankfull flows shown in Table 7-1, the average bankfull cross-sectional area for each geomorphic monitoring station using survey data from the WEST 2021 report was compared with the Minnesota DNR western region curve for this characteristic. Figure 7-1 shows that the bankfull cross-sectional areas generally align within the range of expected values; therefore, the use of these bankfull flows (which generated the associated bankfull cross-sectional areas using the 2021 WEST report survey data) are considered appropriate.

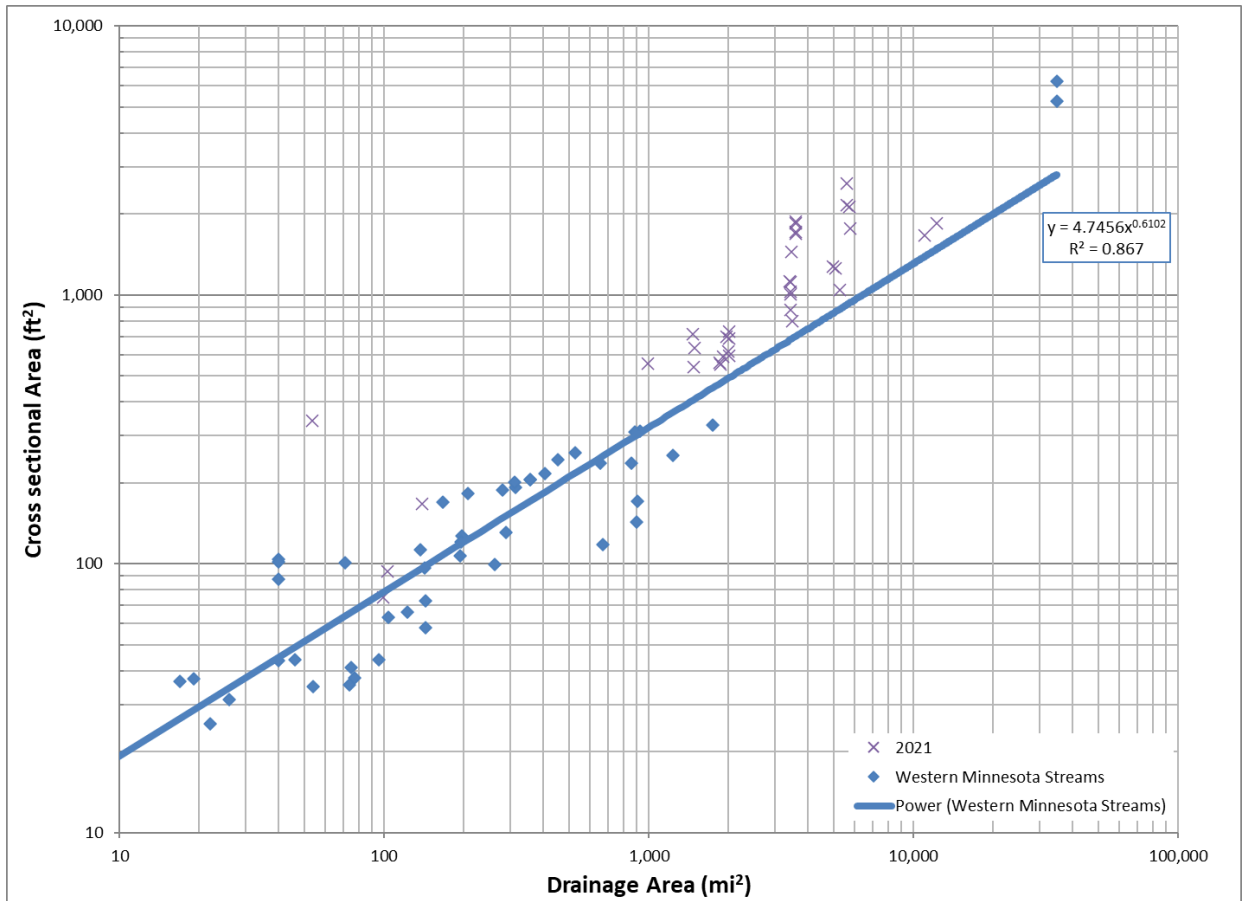

Figure 7-1: Comparison of Bankfull Cross-Sectional Area Calculations for the FMM Project and the MN DNR Western Area Dataset

7.1.2. Entrenchment Ratio Calculation Prescription

The Entrenchment Ratio is calculated for riffle (crossing) sections and is defined as the ratio between the floodprone width and the bankfull width. A close evaluation of the data from the three years of pre- FMM Project monitoring (WEST 2012, 2019, and 2021) indicates that the Entrenchment Ratio can vary substantially because small changes in the floodprone elevation can result in dramatic changes in the floodprone width due to the extremely wide floodplain for streams in the FMM Project vicinity. An example of this is shown in Figure 7-2.

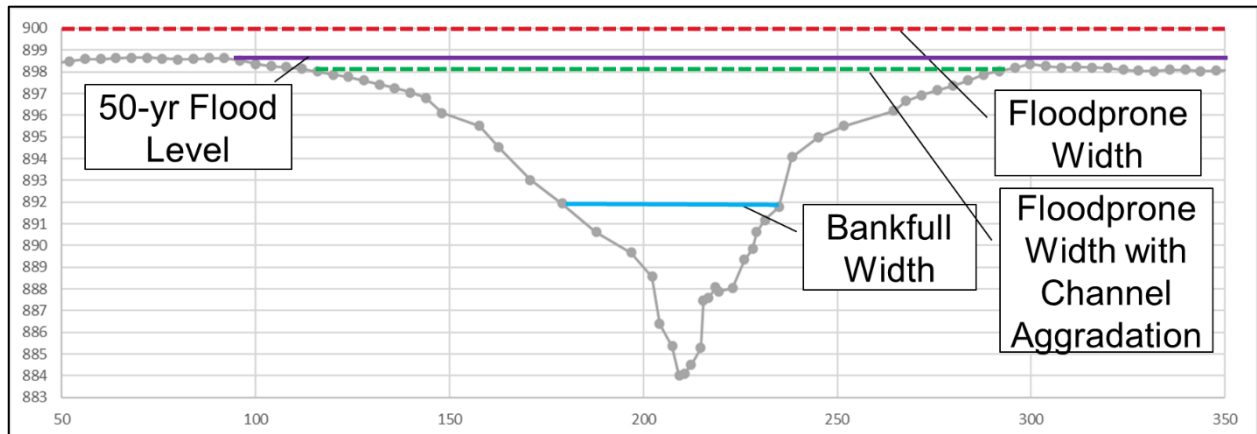

Figure 7-2: Comparison of Floodprone Widths with Small Changes in Floodprone Elevations

Because of the influence on floodprone width in the Entrenchment Ratio calculation, the floodprone width that shall be used for all past and future Entrenchment Ratio calculations completed for the purposes of evaluating trigger exceedance was set to a specified value typically equal to that determined by WEST (2019), with small adjustments at select locations, for each riffle monitoring cross section in the FMM Project vicinity. The specified floodprone widths are shown in Table 7-2. It is noted that in the event the floodprone width exceeded 1,000 feet for all streams besides the Red River, the floodprone width was set to a width of 1,000 feet. For the Red River, the maximum floodprone width threshold was set to 1,500 feet. This ensured that Entrenchment Ratios remained in a reasonable range while also resulting in generally high Entrenchment Ratios that did not approach the low end of the “fully functioning” (per the MN SQT) Entrenchment Ratio threshold.

As of 2022, the GMT and the AMT determined that the Entrenchment Ratio should be calculated using a fixed bankfull elevation. The previous WEST 2012, 2019, and 2021 reports used bankfull flows (see Table 7-1) from which an elevation was determined using a hydraulic model (such as HEC-RAS).

A hydraulic model was used due to the presence of features downstream of each geomorphic monitoring station that influence water surface elevations at bankfull flows. Special attention in the hydraulic model shall be given to boundary conditions to ensure water level changes are associated with changes in cross-sectional geometry and not with hydraulic modeling techniques. The electronic appendix of each WEST (2012, 2019, and 2021) assessment includes the HEC-RAS models used in the bankfull flow and elevation calculations.

Table 7-2: Floodprone Widths for Riffle Monitoring Cross Sections

Cross Section	Floodprone Width (ft)	Cross Section	Floodprone Width (ft)
BU01X01	253	SH01X07	439
BU01X04	233	SH02X01	1,000
BU01X06	196	SH02X03	1,000
LR01X01	1,000	SH02X04	1,000
LR01X03	1,000	SH02X06	1,000
LR01X06	222	SH03X01	412
MA01X01	1,000	SH03X02	1,000
MA01X03	473	SH03X05	1,000
MA01X05	645	SH04X01	1,000
MA01X06	417	SH04X03	1,000
MA02X01	1,000	SH04X05	1,000
MA02X03	1,000	SH05X01	1,000
MA02X06	1,000	SH05X03	1,000
MA03X01	1,000	SH05X06	1,000
MA03X04	1,000	SH06AX02	1,000
MA03X06	1,000	SH06AX04	1,000
RE01X01	768	SH06AX05	1,000
RE01X03	559	SH06X02	1,000
RE01X05	850	SH06X03	1,000
RE01X07	530	SH06X05	1,000
RE02X01	540	SH07X01	1,000
RE02X03	547	SH07X02	1,000
RE02X05	596	SH07X03	1,000
RE02X06	726	SH07X04	1,000
RE02X08	720	SH07X05	1,000
RE02X10	485	SH07X08	1,000
RE03X01	1,037	SH08X01	1,000
RE03X03	980	SH08X06	1,000
RE03X05	1,395	WC01X03	61
RE03X06	1,325	WC01X05	91
RE04X01	765	WC01X06	51
RE04X03	1,500	WC02X02	84
RE04X05	1,500	WC02X04	120
RE05X02	1,500	WC02X06	122
RE05X04	1,406	WC03X01	142
RE05X06	942	WC03X04	142
RE06AX01	1,500	WC03X06	157
RE06AX04	1,500	WC04X02	180
RE06AX06	1,500	WC04X04	144
RE06X01	1,500	WC04X06	157
RE06X02	1,500	WR01X01	444

Cross Section	Floodprone Width (ft)	Cross Section	Floodprone Width (ft)
RE06X03	1,500	WR01X03	383
RE06X05	1,500	WR01X06	328
RE07X01	1,087	WR02X02	1,000
RE07X03	1,500	WR02X04	338
RE07X06	1,171	WR02X06	287
RE08AX02	645	WR03X01	295
RE08AX04	478	WR03X04	289
RE08AX06	1,500	WR03X06	611
RE08X01	893	WR04X02	331
RE08X03	800	WR04X03	359
RE08X04	1,109	WR04X04	270
RE08X06	1,104	WR04X06	288
RE09X02	1,500	WR05X01	240
RE09X03	495	WR05X03	215
RE09X05	1,075	WR05X06	218
RE09X06	1,500	WR06X01	239
RE10X01	1,167	WR06X02	282
RE10X03	1,282	WR06X04	215
RE10X05	1,500	WR06X06	353
RE10X06	1,210	WR07X01	696
RU01X01	1,000	WR07X03	842
RU01X02	1,000	WR07X05	468
RU01X04	1,000	WR07X06	510
RU01X07	249	WR08X01	447
SH01X01	859	WR08X05	503
SH01X03	920	WR08X07	361
SH01X05	798		

Once the Entrenchment Ratios for each monitoring cross section are calculated using the methodology listed above based upon bankfull elevations, the average Entrenchment Ratio of the riffle monitoring cross sections within each geomorphic monitoring station shall then be averaged to determine the geomorphic monitoring station Entrenchment Ratio, which is the basis for comparison to the trigger values.

The new methodology to calculate the Entrenchment Ratios based upon bankfull elevations will not be used until the next set of investigations. Therefore, the following results of the previous calculations based upon bankfull flows are presented for each geomorphic monitoring station as calculated based on the 2012, 2019, and 2021 assessment survey data. The results of these calculations are shown in Table 7-3, Table 7-4, and Table 7-5, respectively. The Entrenchment Ratio values in these tables were then used to establish the maximum and minimum pre- FMM Project Entrenchment Ratio for each stream for trigger setting purposes. In the event additional pre-FMM Project data is collected, the triggers shall be adjusted (as necessary) in the event the

range of pre-FMM Project data increases compared to the data set provided in the tables below. It is noted that the calculated Entrenchment Ratio values for trigger identification purposes may differ from those presented in the WEST (2012, 2019, and 2021) reports because it was not possible for WEST to use a constant floodprone width or bankfull flow for each geomorphic monitoring cross section over the course of the three assessment years.

Table 7-3: Entrenchment Ratios using 2012 Survey Data and the Calculation Methodology Outlined in this Section

GMS	Entrenchment Ratio	GMS	Entrenchment Ratio	GMS	Entrenchment Ratio
BU-01	3.0	RE-08	-	SH-08	11.9
LR-01	8.1	RE-08A	-	WC-01	2.4
MA-01	8.2	RE-09	8.4	WC-02	3.9
MA-02	-	RE-10	7.7	WC-03	-
MA-03	11.1	RU-01	26.9	WC-04	-
RE-01	4.1	SH-01	7.5	WR-01	4.5
RE-02	4.2	SH-02	8.3	WR-02	6.1
RE-03	7.0	SH-03	7.9	WR-03	-
RE-04	7.6	SH-04	11.7	WR-04	-
RE-05	7.4	SH-05	13.8	WR-05	2.8
RE-06	-	SH-06A	14.0	WR-06	3.6
RE-06A	10.3	SH-06	-	WR-07	7.3
RE-07	-	SH-07	11.4	WR-08	5.3

Table 7-4: Entrenchment Ratios using 2019 Survey Data and the Calculation Methodology Outlined in this Section

GMS	Entrenchment Ratio	GMS	Entrenchment Ratio	GMS	Entrenchment Ratio
BU-01	-	RE-08	5.8	SH-08	11.5
LR-01	6.7	RE-08A	-	WC-01	-
MA-01	5.3	RE-09	8.5	WC-02	-
MA-02	9.9	RE-10	7.6	WC-03	-
MA-03	9.2	RU-01	17.0	WC-04	-
RE-01	3.9	SH-01	7.9	WR-01	3.8
RE-02	3.8	SH-02	8.7	WR-02	5.8
RE-03	6.7	SH-03	8.2	WR-03	4.6
RE-04	6.8	SH-04	11.5	WR-04	3.1
RE-05	6.9	SH-05	12.7	WR-05	2.7
RE-06	7.9	SH-06A	12.3	WR-06	3.2
RE-06A	9.6	SH-06	12.0	WR-07	6.1
RE-07	8.0	SH-07	10.4	WR-08	4.9

Table 7-5: Entrenchment Ratios using 2021 Survey Data and the Calculation Methodology Outlined in this Section

GMS	Entrenchment Ratio	GMS	Entrenchment Ratio	GMS	Entrenchment Ratio
BU-01	2.8	RE-08	6.6	SH-08	11.8
LR-01	6.4	RE-08A	6.4	WC-01	2.0
MA-01	8.3	RE-09	8.6	WC-02	5.0
MA-02	10.4	RE-10	8.1	WC-03	3.9
MA-03	10.0	RU-01	18.1	WC-04	4.9
RE-01	3.9	SH-01	7.9	WR-01	4.0
RE-02	3.9	SH-02	8.5	WR-02	6.0
RE-03	7.4	SH-03	7.5	WR-03	5.4
RE-04	6.3	SH-04	10.7	WR-04	3.3
RE-05	6.3	SH-05	12.2	WR-05	2.6
RE-06	9.2	SH-06A	10.2	WR-06	3.0
RE-06A	10.3	SH-06	10.8	WR-07	8.0
RE-07	8.9	SH-07	9.9	WR-08	5.2

7.1.3. Bank Height Ratio Calculation Prescription

The Bank Height Ratio is calculated for riffle (crossing) sections and is defined as the ratio between the low bank height and maximum bankfull depth. A close evaluation of the data from the three years of pre-FMM Project monitoring (WEST 2012, 2019, and 2021) indicates that the Bank Height Ratio can vary substantially due to different interpretations of low bank height by the geomorphic investigator. An example of this is shown in Figure 7-3.

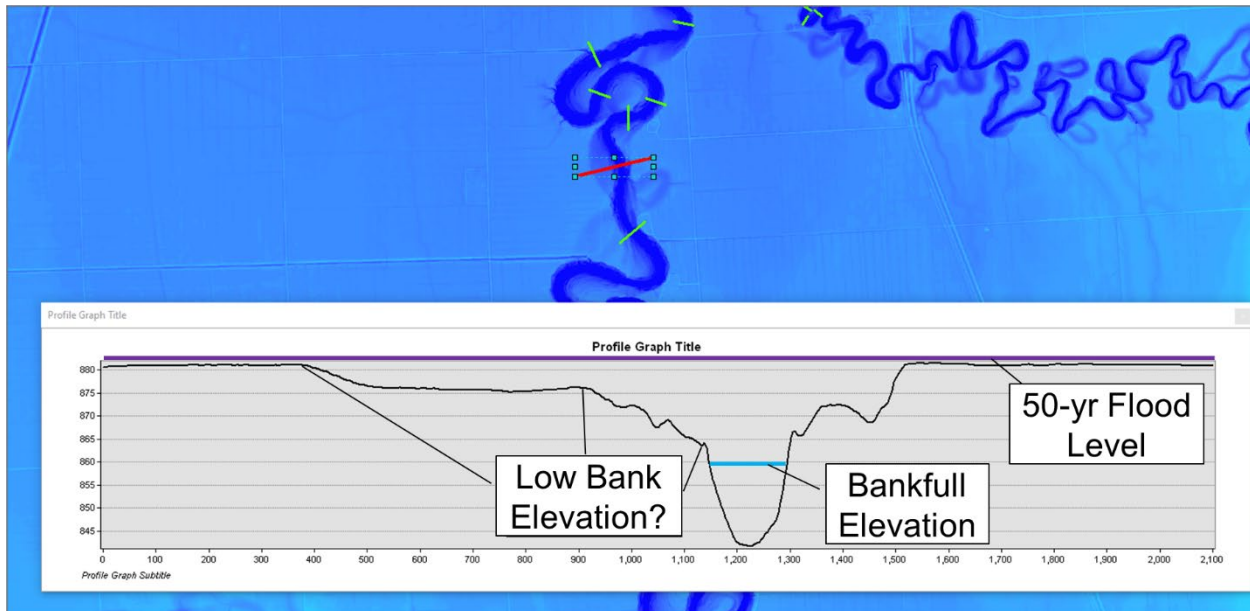

Figure 7-3: Comparison of Low Bank Height Possibilities

Because of the influence of the low bank elevation in the Bank Height Ratio calculation, the low bank elevation that shall be used for all past and future Bank Height Ratio calculations completed for the purposes of evaluating trigger exceedance was set to a specified value typically equal to that determined by WEST (2019), with small adjustments at select locations, for each riffle monitoring cross section in the FMM Project vicinity. The specified low bank elevations are shown in Table 7-6.

Finally, as discussed in Section 2, an accurate establishment of bankfull flows is integral to the Bank Height Ratio calculation. Therefore, all Bank Height Ratio calculations completed for the purposes of evaluating trigger exceedance shall use the bankfull flow rates shown in Table 7-1 and a hydraulic model (such as HEC-RAS) to determine the bankfull elevation from which the maximum bankfull depth is to be calculated. A hydraulic model shall be used due to the presence of features downstream of each geomorphic monitoring station that influence water surface elevations at bankfull flows. Special attention in the hydraulic model shall be given to boundary conditions to ensure water level changes are associated with changes in cross-sectional geometry and not with hydraulic modeling techniques. The electronic appendix of each WEST (2012, 2019, and 2021) assessment includes the HEC-RAS models used in the bankfull flow and elevation calculations.

Table 7-6: Low Bank Elevations for Riffle Monitoring Cross Sections

Cross Section	Low Bank Elevation (ft NAVD88)	Cross Section	Low Bank Elevation (ft NAVD88)
BU01X01	859.8	SH01X07	875.3
BU01X04	862.9	SH02X01	884.2
BU01X06	862.1	SH02X03	883.9
LR01X01	896.1	SH02X04	884.7
LR01X03	896.6	SH02X06	884.5
LR01X06	895.7	SH03X01	886.8
MA01X01	888.7	SH03X02	886.8

Cross Section	Low Bank Elevation (ft NAVD88)	Cross Section	Low Bank Elevation (ft NAVD88)
MA01X03	887.4	SH03X05	886.4
MA01X05	887.4	SH04X01	894.0
MA01X06	889.7	SH04X03	893.9
MA02X01	890.8	SH04X05	893.3
MA02X03	890.7	SH05X01	897.5
MA02X06	892.2	SH05X03	902.3
MA03X01	899.8	SH05X06	902.6
MA03X04	897.8	SH06AX02	908.3
MA03X06	898.7	SH06AX04	911.6
RE01X01	857.6	SH06AX05	908.0
RE01X03	857.7	SH06X02	911.3
RE01X05	856.4	SH06X03	911.6
RE01X07	856.6	SH06X05	910.6
RE02X01	862.9	SH07X01	918.3
RE02X03	861.8	SH07X02	915.1
RE02X05	862.2	SH07X03	917.2
RE02X06	863.8	SH07X04	918.8
RE02X08	864.0	SH07X05	918.5
RE02X10	862.0	SH07X08	919.3
RE03X01	875.7	SH08X01	932.9
RE03X03	872.9	SH08X06	932.6
RE03X05	873.7	WC01X03	892.0
RE03X06	873.8	WC01X05	894.2
RE04X01	881.5	WC01X06	896.0
RE04X03	881.5	WC02X02	899.4
RE04X05	881.8	WC02X04	900.3
RE05X02	887.7	WC02X06	901.1
RE05X04	888.2	WC03X01	912.3
RE05X06	887.5	WC03X04	912.7
RE06AX01	888.1	WC03X06	912.7
RE06AX04	891.0	WC04X02	915.0
RE06AX06	890.4	WC04X04	915.2
RE06X01	888.8	WC04X06	914.9
RE06X02	889.7	WR01X01	890.5
RE06X03	888.9	WR01X03	889.9
RE06X05	888.2	WR01X06	891.8
RE07X01	891.4	WR02X02	891.7
RE07X03	890.9	WR02X04	891.0
RE07X06	890.4	WR02X06	891.6
RE08AX02	894.6	WR03X01	895.7
RE08AX04	890.7	WR03X04	896.6

Cross Section	Low Bank Elevation (ft NAVD88)	Cross Section	Low Bank Elevation (ft NAVD88)
RE08AX06	893.4	WR03X06	895.2
RE08X01	891.5	WR04X02	896.9
RE08X03	890.5	WR04X03	899.1
RE08X04	891.8	WR04X04	898.5
RE08X06	894.1	WR04X06	900.0
RE09X02	900.9	WR05X01	901.8
RE09X03	900.9	WR05X03	902.0
RE09X05	901.9	WR05X06	902.2
RE09X06	901.0	WR06X01	906.1
RE10X01	917.1	WR06X02	904.2
RE10X03	917.1	WR06X04	905.2
RE10X05	917.0	WR06X06	905.2
RE10X06	918.3	WR07X01	912.3
RU01X01	893.4	WR07X03	914.0
RU01X02	892.2	WR07X05	914.5
RU01X04	894.0	WR07X06	915.7
RU01X07	893.6	WR08X01	918.7
SH01X01	872.1	WR08X05	914.3
SH01X03	871.0	WR08X07	917.1
SH01X05	873.3		

Once the Bank Height Ratios for each monitoring cross section are calculated using the methodology listed above, the average Bank Height Ratio of the riffle monitoring cross sections within each geomorphic monitoring station shall then be averaged to determine the geomorphic monitoring station Bank Height Ratio, which is the basis for comparison to the trigger values.

Using the Bank Height Ratio calculation process listed above, the Bank Height Ratios for each geomorphic monitoring station were calculated based on the 2012, 2019, and 2021 assessment survey data. The results of these calculations are shown in Table 7-7, Table 7-8, and Table 7-9, respectively. The Bank Height Ratio values in these tables were then used to establish the maximum and minimum pre- FMM Project Bank Height Ratio for each stream for trigger setting purposes. In the event additional pre- FMM Project data is collected, the triggers shall be adjusted (as necessary) in the event the range of pre- FMM Project data increases compared to the data set provided in the tables below. It is noted that the calculated Bank Height Ratio values for trigger identification purposes may differ from those presented in the WEST (2012, 2019, and 2021) reports because it was not possible for WEST to use a constant low bank elevation or bankfull flow for each geomorphic monitoring cross section over the course of the three assessment years.

Table 7-7: Bank Height Ratios using 2012 Survey Data and the Calculation Methodology Outlined in this Section

GMS	Bank Height Ratio	GMS	Bank Height Ratio	GMS	Bank Height Ratio
BU-01	1.3	RE-08	-	SH-08	1.4
LR-01	1.4	RE-08A	-	WC-01	2.1
MA-01	1.2	RE-09	1.2	WC-02	1.1
MA-02	-	RE-10	1.2	WC-03	-
MA-03	1.2	RU-01	1.5	WC-04	-
RE-01	1.2	SH-01	1.2	WR-01	1.3
RE-02	1.2	SH-02	1.4	WR-02	1.1
RE-03	1.0	SH-03	1.1	WR-03	-
RE-04	1.0	SH-04	1.3	WR-04	-
RE-05	1.1	SH-05	1.3	WR-05	1.1
RE-06	-	SH-06A	1.4	WR-06	1.2
RE-06A	1.0	SH-06	1.2	WR-07	1.0
RE-07	-	SH-07	1.3	WR-08	1.1

Table 7-8: Bank Height Ratios using 2019 Survey Data and the Calculation Methodology Outlined in this Section

GMS	Bank Height Ratio	GMS	Bank Height Ratio	GMS	Bank Height Ratio
BU-01	-	RE-08	1.0	SH-08	1.4
LR-01	1.2	RE-08A	-	WC-01	-
MA-01	1.1	RE-09	1.2	WC-02	-
MA-02	1.0	RE-10	1.1	WC-03	-
MA-03	1.1	RU-01	1.2	WC-04	-
RE-01	1.2	SH-01	1.3	WR-01	1.1
RE-02	1.2	SH-02	1.4	WR-02	1.1
RE-03	1.0	SH-03	1.3	WR-03	1.0
RE-04	1.0	SH-04	1.4	WR-04	1.0
RE-05	1.0	SH-05	1.3	WR-05	1.1
RE-06	1.0	SH-06A	-	WR-06	1.1
RE-06A	1.0	SH-06	1.2	WR-07	0.9
RE-07	1.0	SH-07	1.3	WR-08	1.0

Table 7-9: Bank Height Ratios using 2021 Survey Data and the Calculation Methodology Outlined in this Section

GMS	Bank Height Ratio	GMS	Bank Height Ratio	GMS	Bank Height Ratio
BU-01	1.3	RE-08	1.0	SH-08	1.4
LR-01	1.1	RE-08A	1.1	WC-01	1.7
MA-01	1.1	RE-09	1.3	WC-02	1.2
MA-02	1.0	RE-10	1.3	WC-03	0.8
MA-03	1.1	RU-01	1.2	WC-04	0.9
RE-01	1.2	SH-01	1.3	WR-01	1.1
RE-02	1.3	SH-02	1.4	WR-02	1.1
RE-03	1.1	SH-03	1.2	WR-03	1.2
RE-04	1.0	SH-04	1.3	WR-04	1.1
RE-05	1.0	SH-05	1.3	WR-05	1.1
RE-06	1.0	SH-06A	1.1	WR-06	1.2
RE-06A	1.0	SH-06	1.0	WR-07	1.2
RE-07	1.0	SH-07	1.2	WR-08	1.2

7.1.4. Aerial-Image Derived Bank Line Locations

Identification of bank line locations using aerial imagery is dependent on many factors, including scale, process, and judgment. The following protocol has been used by WEST in their geomorphic assessments and is recommended for use in future assessments for trigger comparison purposes. For demonstration purposes, the protocol described below uses the year 2020, which is the most recent year for which bank line locations were delineated by WEST in their 2021 report. The actual year in the protocol will change and should be based on the most recent year for which bank line locations have been delineated.

- Load the 2020 aerial imagery and 2020 delineated bank line shapefile into GIS.
- Set the scale in GIS to 1:1,000, which is the scale at which the WEST (2021) assessment delineated bank line locations.
- Compare the delineated 2020 bank line locations with the 2020 aerial imagery to understand and the general judgment process used for delineating the 2020 bank line locations so it can be replicated for determining the current year bank line locations.
- Make a copy of the 2020 bank line locations shapefile, rename it to the current year being evaluated, and load it into GIS.
- Load the current year aerial imagery into GIS.
- Compare the copied/rename 2020 bank line locations shapefile with the current year aerial imagery. If bank line locations have notably moved at the 1:1,000 scale, edit the copied/rename 2020 bank line locations shapefile to reflect the change.

In the event multiple years of aerial imagery are to be evaluated during one assessment, the use of the most recent year of delineated bank lines should still be used. For example, if conducting an assessment using 2023 and 2026 aerial imagery, the 2020 bank line shapefile should be the one edited to define the 2023 bank line locations, while the newly created 2023 bank line

shapefile should be the one edited to define the 2026 bank line locations, always working in sequential order from oldest to newest imagery.

If channel sinuosity, meander amplitude, or meander frequency metrics are desired, the following process shall be used:

- Create stream centerline shapefiles using the delineated left and right bank line shapefiles and the “Collapse Dual Lines to Centerline” tool in ArcGIS’s ArcToolbox (or similar tool for a different GIS program). Centerlines obtained from the “Collapse Dual Lines to Centerline” tool are very similar and for the most part identical to what would be obtained if the stream centerline were digitized separately.
- Use the methodology described in Heo et al. (2009) to find the centroid and radius of an imaginary circle best fit to the data points along the digitized bank line that represents the bend line.

7.1.5. Use of Video Footage to Document Changes in Geomorphology

The Corps is working with WEST to evaluate video footage methods to document unstable banks, erosion, deposition, and other changes that could occur due to the Project or other items. The study will consider technical and economic factors related to the use of drone-mounted LiDAR, multiple cameras mounted on boats, and other methods. Following the study, the results shall be presented to the AMT for further consideration to improve data collection.

7.2. Protocols for Other Work

7.2.1. Survey Data

Cross-sectional survey data below the top of bank shall be collected with no more than 10 feet between each point, with at least 5 points along the channel bottom and 3 points along each channel bank, as well as points at every notable slope change location. Between the cross-section monuments and top of bank, data shall be collected with no more than 20 feet between each point and at every notable slope change location. Longitudinal profile data shall be collected with no more than a 10 foot spacing between each point along the profile.

7.2.2. Sediment Sample Analysis

All sediment samples shall be assessed by identifying the classification (following ASTM D2488), particle size distribution (following ASTM D7928), particle density (following ASTM D854, Method B), and organic content analysis (following ASTM D2974, Method C). A photograph and the northing and easting location for each sample collected shall also be collected.

7.2.3. Rosgen Assessments

All Rosgen assessments and worksheets shall be conducted and completed in accordance with those processes outlined in Watershed Assessment of River Stability and Sediment Supply (Rosgen, 2006). All field assessment crew leads shall have at least 10 years of experience in riverine geomorphic assessments, measurements, and analysis. If more than one field crew is deployed at the same time, the field crew lead for each team shall meet this requirement. It is also recommended, though not required, that all geomorphic assessment field crew leads have Rosgen training through the Level III channel stability assessment.

7.2.4. Data Management

The RIVERMorph data management software package (www.rivermorph.com) associated with the Rosgen stream assessments should be part of the data management and analysis package. Surveyed cross-sectional data, field-observed bankfull elevations, longitudinal profile data, sediment size data, roughness parameters, and riparian vegetation characteristics shall be entered into the software for each cross section. If field-observed values (such as bankfull elevation calls) are manually changed or altered due to additional/outside analysis (such as HEC-RAS or other modeling), the Contractor shall include a list of the changes as well as the explanation for each change. This list shall include both the field-estimated values as well as the adjusted values.

Other data, such as survey data, hydraulic models, spreadsheets analyses, and GIS data, shall be provided in an electronic format as an attachment to the geomorphic assessment report.

Data Storage and Exchange

The data will need to be accessible and shared for redundancy and analysis purposes as well as stored as part of the monitoring record and for future data needs. The FMM Project's non-Federal sponsors shall manage and host the official repository of all of the data sets and completed analysis related to the FMM Project into perpetuity and make this data accessible via a web interface. Data from the watershed districts and others may be included in this data base. At present, the Aconex site (<https://us1.aconex.com/Logon>) serves as the repository for all reports and associated electronic data. The FMM Project's non-Federal sponsors shall provide access to this site for all members of the GMT and AMT upon request.

Raw data shall be shared within 2 months of the end of the data collection or as soon as possible. Post-processed data shall be shared with all GMT and AMT members within 2 weeks of finalization. Results shall be shared to AMT members at least 6 months prior to the next anticipated field geomorphic monitoring effort.

8. GEOMORPHIC MONITORING SCHEDULE AND GMP UPDATES

8.1. Pre-FMM Project

A total of three pre-FMM Project geomorphic assessments have been completed and are documented in WEST (2012, 2019, and 2021). All three sets of monitoring results were analyzed by the GMT during working meetings initiated within 90 calendar days of the final 2021 WEST report, noting any changes deemed significant by the GMT. The working meetings for interpreting the analyzed data with regards to geomorphic stability should be open and scheduled for participation by all of the interested agencies. It is noted that external facilitation might be a beneficial approach, especially if it is anticipated that reaching consensus decisions may be difficult. As a result of the meetings, the GMT provided a summary of the interpretation and a list of recommended GMP updates (if any) to the AMT within 180 calendar days of the final 2021 WEST report.

The GMT considered the following in their recommendations:

- the magnitude and rate of the noted changes and the significance of the potential consequences resulting for those changes, including whether triggers should be added, removed, or adjusted
- whether each geomorphic assessment component is providing relevant and valuable information and, if it is not, recommend additions/subtractions/alterations to the AMT to ensure the appropriate data is being gathered
- whether the monitoring schedule for different reaches is appropriate, and if not, identify what frequency of sampling is needed (for example, if the Red River is deemed to be more stable than the tributaries, the tributaries may need more frequent monitoring than the Red River)

The AMT will ultimately be responsible for determining appropriate responses and actions based on the GMT recommendations.

During Project Construction Prior to Operations: Pre-operation sampling events may occur during construction if a large flood event occurs that would have resulted in operation of the Red River and Wild Rice River structures if the Project construction was complete which is defined as an event when the combined flows at the USGS gages on the Red River at Enloe and the Wild Rice River at Abercrombie exceed 21,000 cfs, equivalent to slightly less frequent than a 5% annual exceedance probability event. In the event of multiple successive years of project operation floods, the GMT will meet to recommend whether the second or later events are monitored and at what level of detail based on the data collected from the previous event(s). After successive events close in time, the GMT will meet to see if it can identify criteria for supporting the decision-making process related to future assessments. Information collected during Project Construction will be compared to information presented in the 2012, 2019, and 2021 reports to provide a baseline for comparisons to post-FMM Project conditions.

8.2. Post-FMM Project

Post-FMM Project, data for field data-based investigations (see Section 5.1) shall be collected within one year of FMM Project completion and a report summarizing the geomorphic monitoring efforts (see Sections 5.2 through 5.4) finalized within 2 years to establish baseline post-FMM Project conditions. Two additional Post-FMM Project geomorphic assessments shall

also be completed: one 5 years after this initial post-FMM Project assessment and one 10 years after the initial assessment.

It is noted that the total cost of each pre-FMM Project geomorphic assessment was approximately \$1,000,000 for the combined survey and geomorphic assessment effort. Therefore, to ensure taxpayer funds are used in an efficient, effective, and appropriate manner, the GMT shall convene and provide a recommendation to the AMT about reducing the geomorphic assessment frequency to every 10 years (or some other frequency), especially if no significant changes in the channel morphology are noted. As part of its recommendation to the AMT, the GMT shall also consider whether future assessment efforts should only be focused on any areas exhibiting significant changes.

For each of the areas flagged for further investigation by the aerial imagery-based stability analysis, a site-specific field reconnaissance and survey may need to be conducted to understand the local conditions of the site and to help understand the causation for the noted changes.

The first three sets of post-FMM Project monitoring results shall be analyzed by the GMT during working meetings following receipt of the third round of post-FMM Project monitoring (e.g., 10 years after the initial post-FMM Project geomorphic monitoring), noting any changes deemed significant by the GMT. These meetings shall be initiated within 90 calendar days of the finalization of the third post-FMM Project report. The working meetings for interpreting the analyzed data with regards to geomorphic change should be open and scheduled for participation by all of the interested agencies. It is noted that external facilitation might be a beneficial approach, especially if it is anticipated that reaching consensus decisions may be difficult. As a result of the meetings, the GMT shall then provide a summary of the interpretation and a list of recommended GMP updates (if any) to the AMT within 180 calendar days of the finalization of the third post-FMM Project report. At a minimum, the GMT should consider the following in their recommendations:

- the magnitude and rate of the noted changes and the significance of the potential consequences resulting for those changes, including whether triggers should be added, removed, or adjusted
- whether each geomorphic assessment component is providing relevant and valuable information and, if it is not, recommend additions/subtractions/alterations to the AMT to ensure the appropriate data is being gathered
- what future post-FMM Project monitoring schedule is needed (for example, once every 10 years, only after the FMM Project operates, etc.), taking into consideration that the monitoring schedule may differ for different reaches
- what future aerial imagery collection schedule is needed, with data collected the year prior to the next scheduled geomorphic assessment so that the data is available for the assessment

8.3. Flood Event

If a flood occurs that would have resulted or did result in operation of the Red River and Wild Rice River structures, another geomorphic assessment shall occur. The field investigation portion of the geomorphic assessments shall be completed either by the end of the calendar year in which the operation occurred or within 6 months after flows recede to below bankfull flow levels, whichever is later. The final flood event report shall be provided within 1 year of the completion of the field investigation effort.

The GMT shall be provided an opportunity to provide input to and review the flood event scope of work prior to the field assessment being conducted. All comments shall be provided by the GMT to USACE or the non-Federal sponsors, as appropriate, within 21 calendar days of scope of work receipt.

The GMT shall provide a recommendation to the AMT whether a flood event assessment can be used as a substitute for any regularly-scheduled geomorphic assessment.

8.4. Trigger Timelines

When triggers are known to be exceeded, likely either a result of public/agency notification and subsequent review or as a result of a post-FMM Project geomorphic assessment, GMT meeting(s) will be held within 30 calendar days of notification for the purpose of making recommendations to the AMT in accordance with the process outlined in Section 6.2. The GMT shall then provide recommendations to the AMT for action / no action supported by data, analysis, and discussion by the experts within the next 30 calendar days for a total of 60 calendar days from notification to recommendation. The GMT shall remain responsive to the AMT, providing additional information and clarifications when requested and may need to call additional meeting(s) if further recommendations are required to achieve a rated consensus.

As part of the AMT's consideration of the GMT's recommendations, for effective adaptive management, the AMT, GMT, and other monitoring teams shall meet together to discuss the inter-related impacts of the changes in the system and potential corrective actions. Near bank vegetation and habitat both in and out of the stream are tied to the geometric and geomorphic characteristics of a stream.

9. GEOMORPHIC MONITORING TEAM COMMUNICATION PLAN AND DECISION PROCESS

To successfully implement a GMP will require coordinated communication and clear decision rules for the collaborative work of the agencies and stakeholders in planning, funding, and executing the GMP. The AMMP contains much of the structure needed to support GMT; therefore, the communication plan described herein is in addition to the structure outlined in the AMMP. Requests from GMT members to schedule meetings to discuss specific concerns (i.e., meetings that not regularly scheduled) shall be addressed within 30 calendar days of the request being made.

9.1. Communication Plan and Meetings

Regularly-scheduled annual or more frequent communication shall be established with GMT members, any interested AMT member(s), representatives from agencies, and other interested stakeholders (including but not limited to the USDA-NRCS, college extension services, farming co-ops and local landowners, irrigation and drainage districts, etc.). Such communication efforts will allow for real or perceived changes in channel morphology to be documented and flagged for further evaluation.

Regular communications will help focus the monitoring efforts and allow for concerns to be documented and appropriately addressed.

Prior to each of the post-FMM Project geomorphic assessments, coordination between the identified technical experts/organizations shall be done at least 6 months in advance of the actual field work to allow for schedule adjustments or GMP modifications. It is acknowledged that the AMT will be sent the recommended schedule and any deviations based on the geomorphic needs. In turn, the AMT shall be informed at least 6 months in advance of the field season and provided the opportunity to suggest changes or necessary deviations based on other criteria like funding or changes in FMM Project operation and other unanticipated changes. The advance notice is needed to allow time for changes in scope to be negotiated with the geomorphic assessment team (or contractors) after review and input from the GMT.

After each individual geomorphic assessment, a summary of findings shall be presented to the GMT. The GMT members shall also be provided with an opportunity to review each geomorphic assessment report. All GMT member review comments will be due to either USACE or the non-Federal sponsors, as appropriate, within 21 calendar days of report receipt.

As discussed in greater detail in Section 8, working meetings shall also be held to evaluate the three pre-FMM Project geomorphic assessments and the first three post-FMM Project geomorphic assessments with the purpose of determining GMP modification recommendations, as appropriate.

All AMT members shall be informed of and invited to GMT meetings to provide for the opportunity for AMT members to observe and participate in these meetings. GMT members are responsible for informing the AMT of upcoming personnel changes and providing an agency-authorized alternate or replacement upon retirement or reassignment.

The GMT shall be notified by the AMT and/or non-Federal sponsors of geomorphic issues or concerns identified outside of the regular monitoring process and hold a meeting to identify next

steps within 45 calendar days of initial notification to the AMT and/or non-Federal sponsors.

9.2. Decision Process

The GMT is charged with providing expert technical advice and recommendations to the AMT for their consideration. The GMT will use a consensus-based approach for providing recommendations to the AMT. One approach for reaching and documenting consensus that the GMT has used successfully is a 5- point rating that helps distinguish the level of buy in by the participants on a specific recommendation. The 5-point scores are ratings that are not to be added to form an overall score for a specific proposal and does not constitute a vote. Rather, the 5-point scores serve as expert elicitation that can be attributed to specific GMT members if helpful for the AMT consideration.

9.2.1. 5-Point Consensus Rating Scale

The following bullets represent descriptions of each of the 5 ratings:

- 5 – Fully support idea, would endorse and/or help to implement
- 4 – Good idea, maybe not exactly as would have chosen, but good enough
- 3 – Meets expectations, can “live with it” but have some questions and/or reservations
- 2 – Needs improvement and/or have some serious questions or suggestions for revision
- 1 – Poor and/or cannot support in current form at all

9.2.2. 5-Point Consensus Rating Process

The 5-Point consensus process is a rapid way of checking in with a team on their level of buy-in on an idea and to daylight both enthusiasm and issues or concerns with its potential implementation in a documentable format. There are a few steps to the process:

- Formulate recommendation statement
- Participants ask clarifying questions about the recommendation
 - It is important that individuals are clear on what they are rating.
 - At this point, wait to have in-depth discussion of support or concerns until after the rating.
- Each individual rates the recommendation using the 5-point rating scale
 - In a face to face meeting this can start with everyone just raising a hand with the number of fingers raised to indicate their rating and the meeting facilitator can do a quick hand count of the groups rating.
 - On a virtual meeting the scores may be entered into a chat feature, spoken by the attendees, or using a polling tool or white board for people to indicate on the 5-point scale their rating.
- For any scores 3 and below: the individual shall share what it would take to raise the score to a 4
 - The very process of choosing a score helps an individual identify why they believe their rating is correct. The individual will have a sense of what prevents it from having a higher score and why it does not deserve a lower score, which will allow benefits and concerns to be captured and discussed.
 - Sharing that insight with the team helps identify a path forward through discussion or needed actions for issue resolution.

- If all scores rise to a score of 3 or higher the GMT recommendation shall be carried forward to the AMT.
 - Ask for and document any remaining questions or issues or endorsements for the recommendation that the GMT experts would like the AMT to consider in their decisions.
- If scores remain below 3 then the recommendation can be dropped, or specific tasks defined to resolve remaining issues for future consideration by the GMT.
- Finally, document the recommendations with a tally of the ratings and statements of support, issue consideration and resolution, and outstanding questions for future consideration to forward to the AMT. This provides the AMT with a complete understanding of the level of consensus and details that may help the AMT's decision process.

10. REFERENCES

- Heo, J., Duc, T., Cho, H., Choi, S., 2009. Characterization and Prediction of Meandering Channel Migration in the GIS Environment: A Case Study of the Sabine River in the USA. *Environmental Monitoring and Assessment*. 152:155–165.
- Rosgen, D., 1994. A Classification of Natural Rivers. *CATENA*. 22:169-199.
- Rosgen, D., 1996. Applied River Morphology. Wildland Hydrology, Fort Collins, CO.
- Rosgen, D., 2001. The Cross-Vane, W-Weir and J-Hook Vane Structures...Their Description, Design and Application for Stream Stabilization and River Restoration. Wetlands Engineering & River Restoration Conference, Reno, NV.
- Rosgen, D., 2006. Watershed Assessment of River Stability and Sediment Supply (WARSSS). Wildland Hydrology, Fort Collins, CO.
- Smith, E., 2002. BACI Design. *Encyclopedia of Environmetrics*. 1:141-148. Eds. Abdel H. El-Saharawi and Walter W. Piegorsch. Wiley, Chichester.
- WEST Consultants, Inc. (WEST), 2012. Geomorphology Study of the Fargo, ND & Moorhead, MN Flood Risk Management Project. Prepared for US Army Corps of Engineers, St. Paul District.
- WEST Consultants, Inc. (WEST), 2019. Geomorphology Monitoring of Rivers Potentially Affected by the Flood Risk Management Project located within the City of Fargo, Cass County, ND & City of Moorhead, Clay County, MN. Prepared for US Army Corps of Engineers, St. Paul District.
- WEST Consultants, Inc. (WEST), 2021. Geomorphologic Monitoring of Rivers Potentially Affected by the Fargo-Moorhead Metro Flood Risk Management Project. Prepared for US Army Corps of Engineers, St. Paul District.

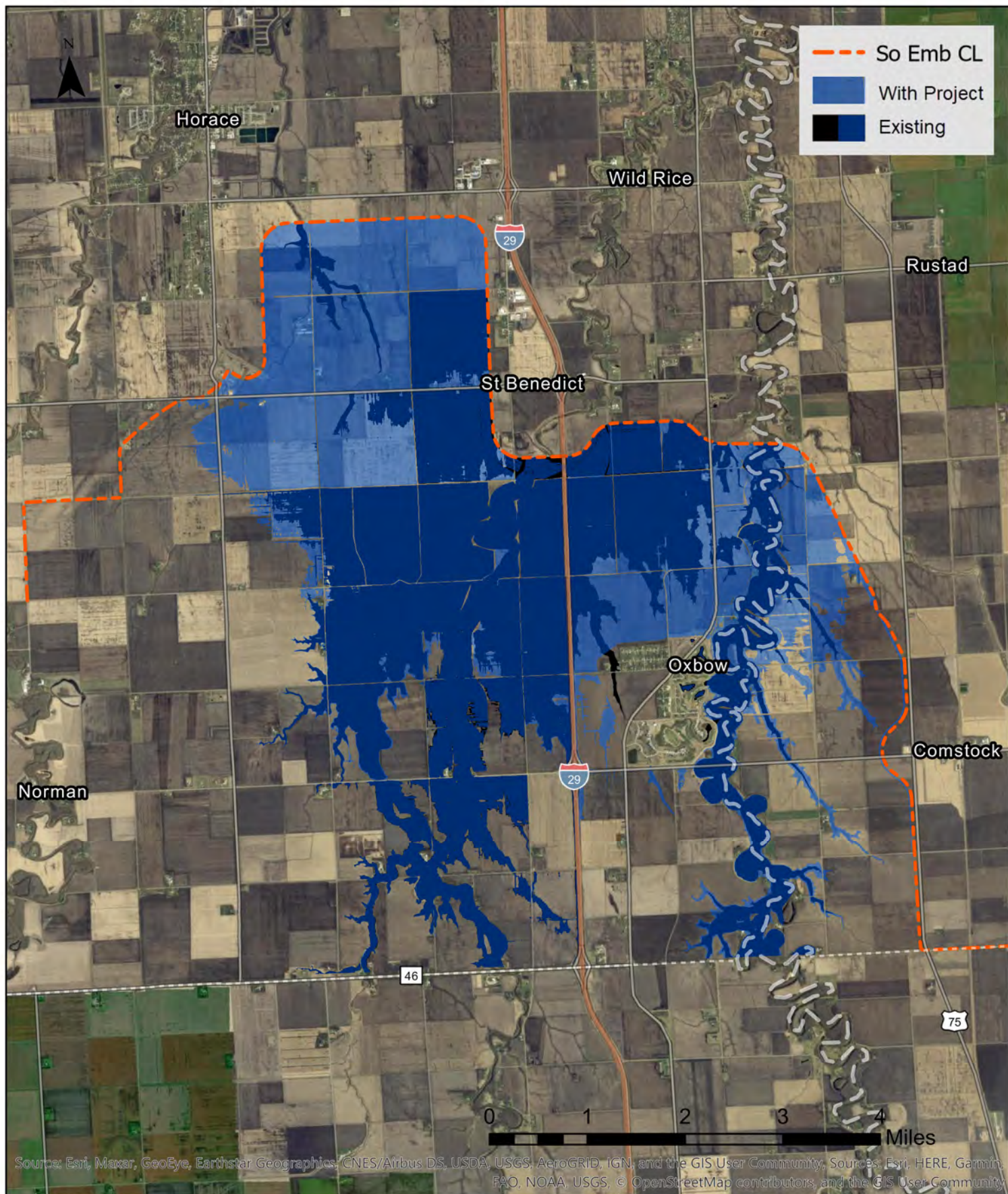

Source: Esri, Maxar, GeoEye, Earthstar Geographics, CNES/Airbus DS, USDA, USGS, AeroGRID, IGN, and the GIS User Community, Sources: Esri, HERE, Garmin, FAO, NOAA, USGS, © OpenStreetMap contributors, and the GIS User Community

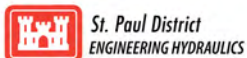

US Army Corps of Engineers

FMM AMMP Southern Embankment 4% AEP Existing vs. With Project Conditions Staging Area Inundation Extents



Created by: b6ecajd6 6/7/2021 11:13 AM

C:_Projects\FMMSoEmb\GIS\AMMP\FishStranding.aprx

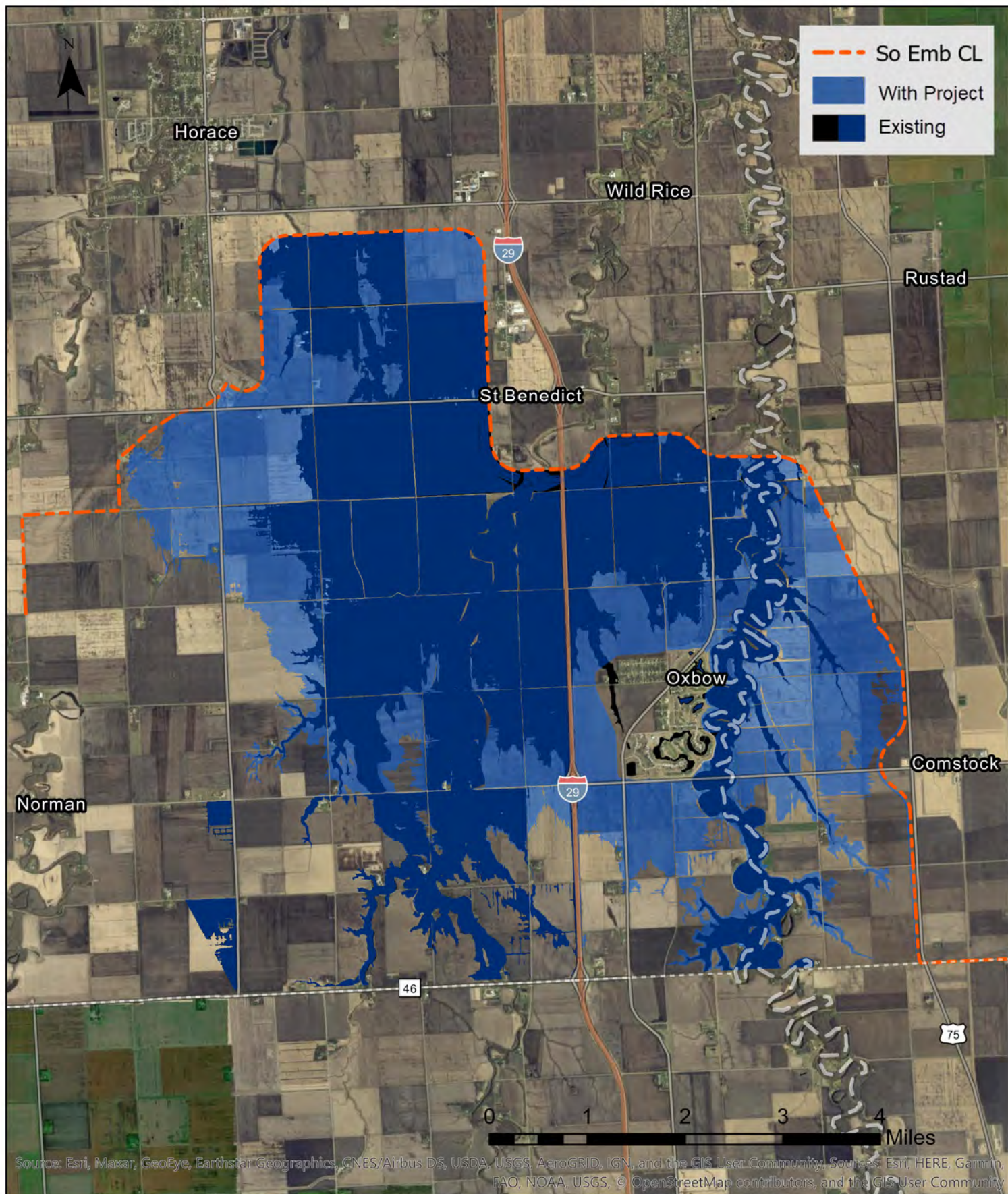

Source: Esri, Maxar, GeoEye, Earthstar Geographics, CNES/Airbus DS, USDA, USGS, AeroGRID, IGN, and the GIS User Community, Sources: Esri, HERE, Garmin, FAO, NOAA, USGS, © OpenStreetMap contributors, and the GIS User Community

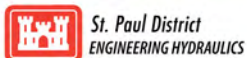

US Army Corps of Engineers®

FMM AMMP Southern Embankment
2% AEP Existing vs. With Project Conditions
Staging Area Inundation Extents



Created by: b6ecajd6 6/7/2021 11:15 AM

C:_Projects\FMMSoEmb\GIS\AMMP\FishStranding.aprx

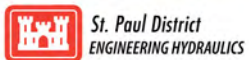
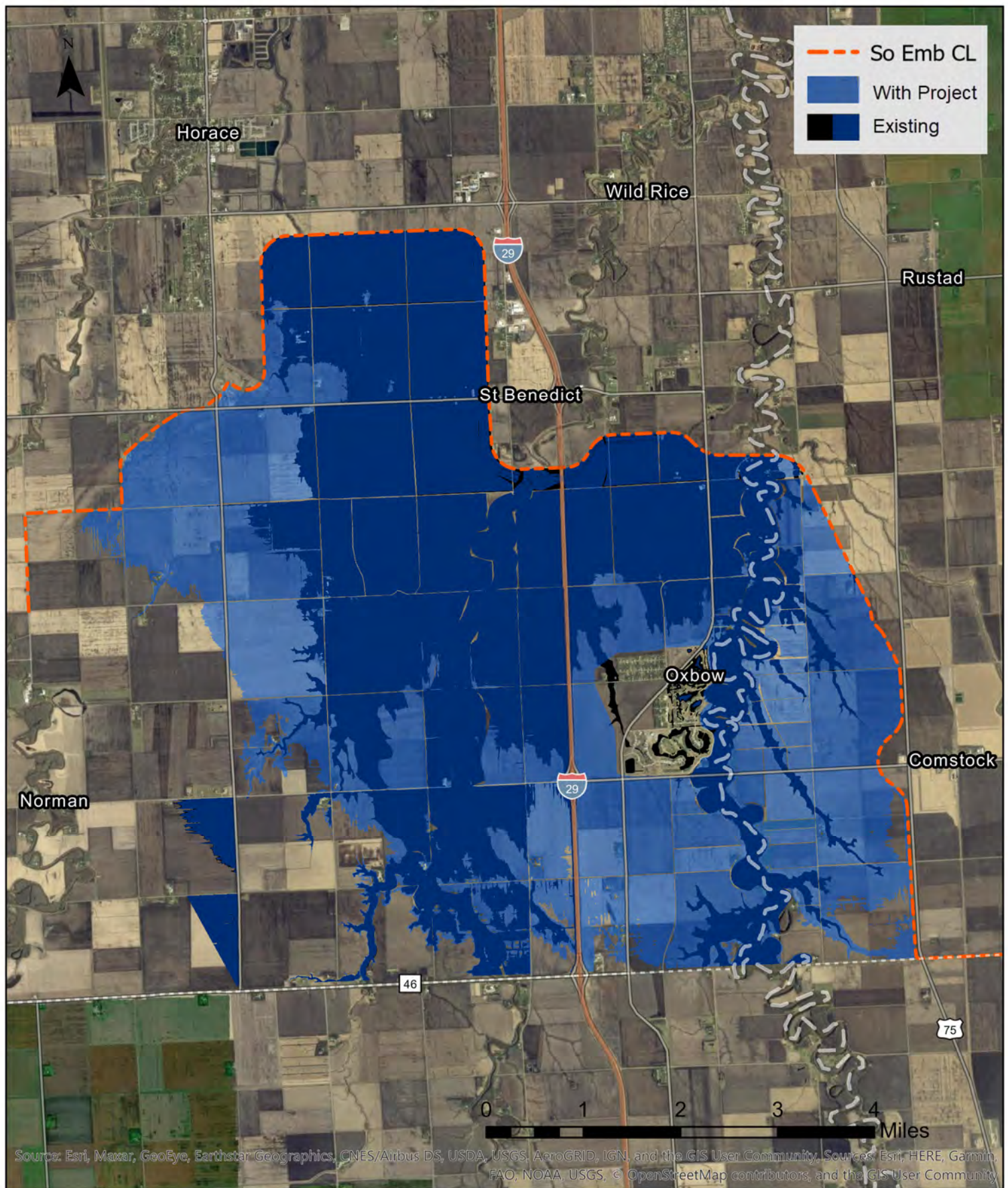

US Army Corps of Engineers®

FMM AMMP Southern Embankment
1% AEP Existing vs. With Project Conditions
Staging Area Inundation Extents



Created by: b6ecajd6 6/7/2021 12:02 PM

C:_Projects\FMMSoEmb\GIS\AMMP\FishStranding.aprx

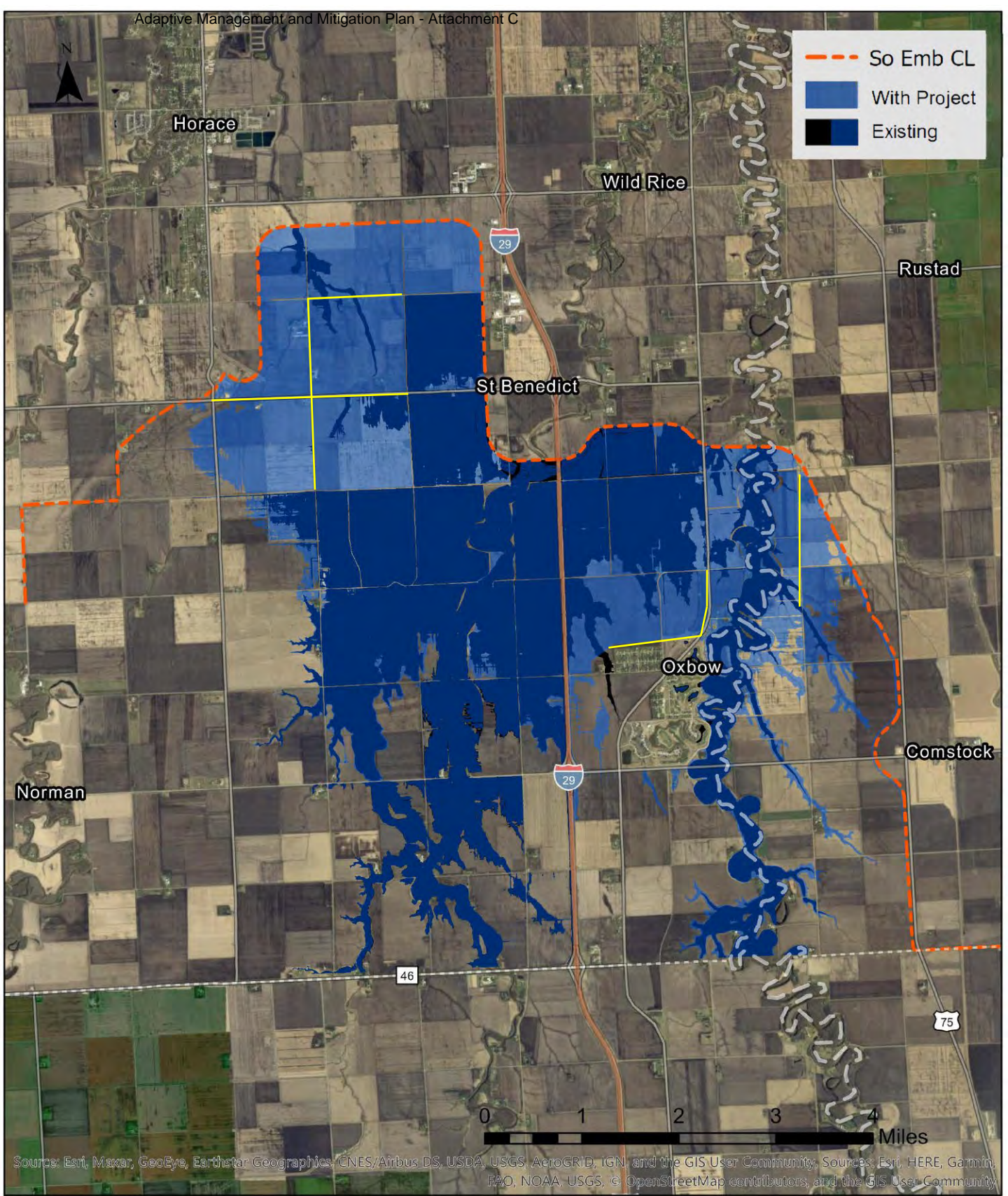

Source: Esri, Maxar, GeoEye, Earthstar Geographics, CNES/Airbus DS, USDA, USGS, AeroGRID, IGN, and the GIS User Community, Sources: Esri, HERE, Garmin, FAO, NOAA, USGS, © OpenStreetMap contributors, and the GIS User Community

FMM AMMP Southern Embankment
4% AEP Existing vs. With Project Conditions
Staging Area Inundation Extents



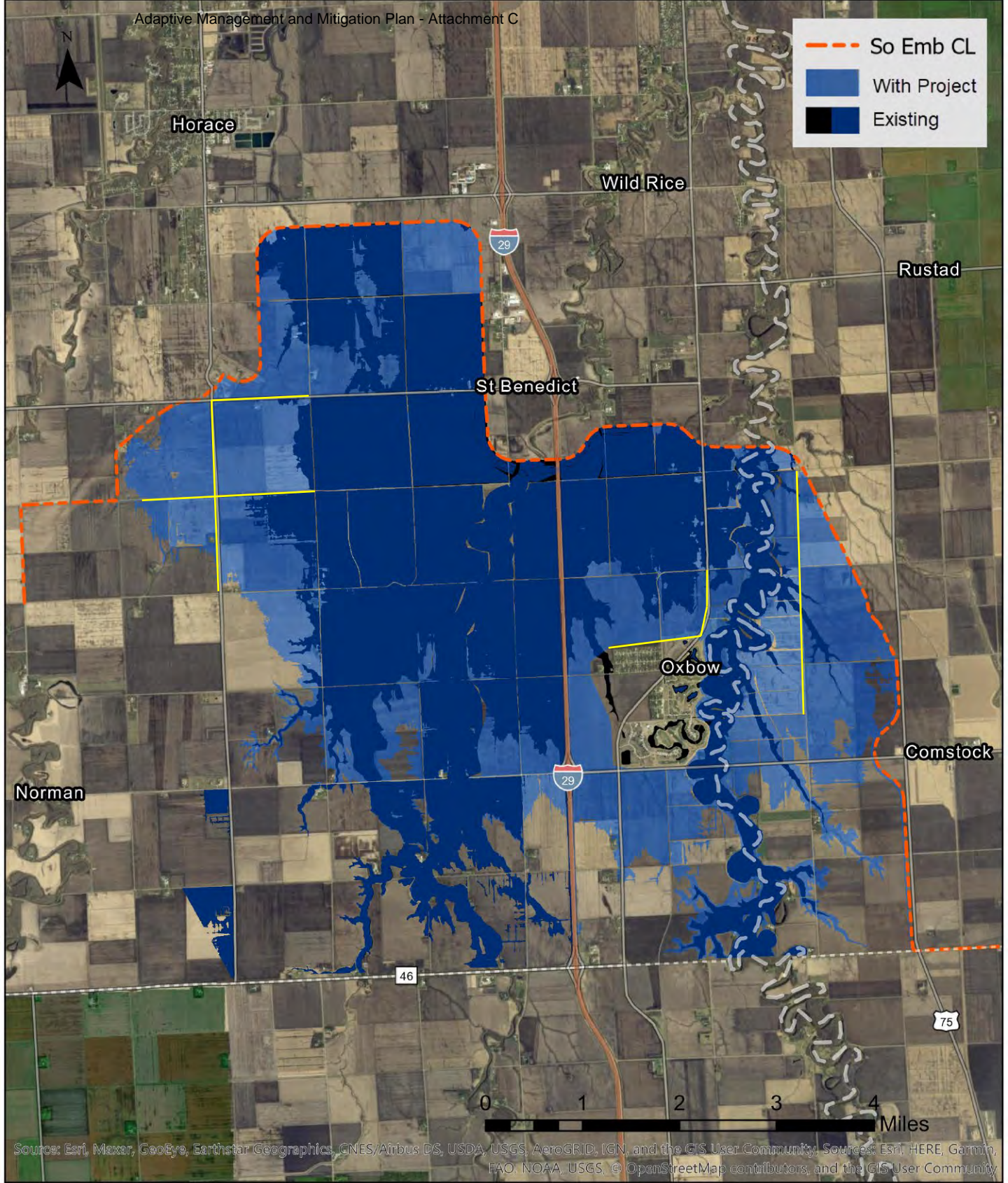

Source: Esri, Maxar, GeoEye, Earthstar Geographics, CNES/Airbus DS, USDA, USGS, AeroGRID, IGN, and the GIS User Community. Sources: Esri, HERE, Garmin, FAO, NOAA, USGS, © OpenStreetMap contributors, and the GIS User Community



